

Body-Solid

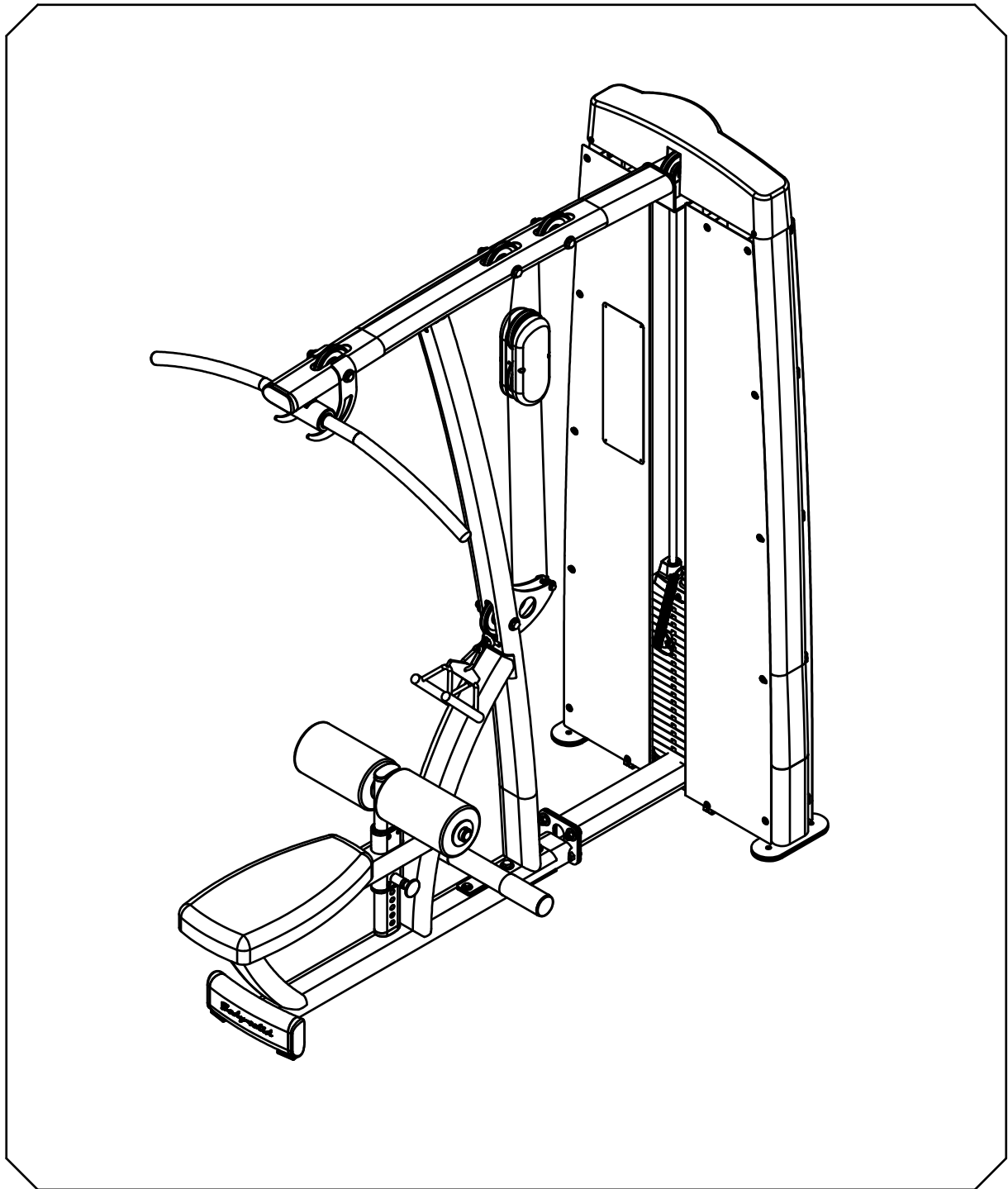

BODY-SOLID, Inc.
1900 S. Des Plaines Ave.
Forest Park, IL 60130 USA
Phone: (708) 427-3555
Fax: (708) 427-3556
www.bodysolid.com

DLAT.2 OWNER'S MANUAL

Warning, Safety & Maintenance

Be sure that all users carefully read and understand all warning, safety and maintenance labels on the machine before each use. Failure to do so may result in death or serious injury.

It is imperative that you retain your Owner's Manual and be sure all warning labels are legible and intact. Replacement Owner's Manuals and warning labels are available from your local Body-Solid dealer.

If you have any questions about the operation, set up or maintenance of this machine please call our customer service department at 1 (800) 556-3113.

THERE IS A RISK ASSUMED BY INDIVIDUALS WHO USE THIS TYPE OF EQUIPMENT. TO MINIMIZE RISK, YOU MUST FOLLOW THESE RULES:

1. Inspect equipment before each workout. Check that all nuts, bolts, screws and pop pins are in place and fully tightened. Also, before use, check cables for signs of wear. Replace all worn parts immediately. Never use machine if any parts are damaged or missing. **FAILURE TO FOLLOW THESE RULES MAY RESULT IN SERIOUS INJURY.**
2. Keep clear of the cables and all moving parts when the machine is in use.
3. Always make sure all Snap Links are closed when doing any cable/pulley/strap exercises.
4. Exercise with care. Perform your exercises at a smooth moderate pace; never perform jerky or uncoordinated movements that may cause injury.
5. It is recommended that you should workout with a training partner.
6. Do not allow children or minors to play on or around this equipment.
7. If unsure of proper use of equipment, call your local Body-Solid distributor or the Body-Solid customer service department at 1-800-556-3113.
8. **WARNING:** Consult your physician before starting your exercise program. For your own safety, do not begin any exercise program without proper instruction. RAL8-6-03 WC-54

WARNING

Safety and Maintenance of Cables

IMPORTANT: Cables are wear items. It is your responsibility to prevent unexpected breakage. **Cable inspection should be performed daily.** Inspect all cables, the nylon coating on all cables, and the area near the fitting at each end of each cable. **Replace any damaged or worn cable immediately.** Do not allow the machine to be used until damaged or worn cables are replaced. Using or allowing a machine to be used with a suspect cable can result in serious injury. See Owner's Manual for more information.

For Body-Solid Customer Service
Call 1-800-556-3113

MAINTENANCE SCHEDULE		D A I L Y	W E E K L Y
Check the function and integrity of the following components. As noted, inspect equipment before each workout. Replace all damaged, broken or worn components immediately.			
Cables:	Check tension, end fittings, and coating	✓	
	Check that locking nut at weight stack is tight		✓
Upholstery:	Wipe down and dry	✓	
	Clean and condition		✓
Frame:	Wipe down and dry	✓	
	Polish / Wax		✓
Chrome:	Wipe down and dry	✓	
	Polish / Lubricate		✓
Nuts / Bolts / Fasteners:	Tighten and / or adjust as needed		✓
Guide Rods:	Lubricate and clean		✓
Linear Rods:	Lubricate and clean		✓
Seat Sleeves:	Lubricate and clean		✓
Adjustments / Locking Pins / Tightening Knobs			✓
Weight Stack Pins			✓
Warning Instruction Labels			✓
Springs / Pop Pins		✓	
Anti Skid Surfaces			✓
Hand Grips / Rollers			✓

For Body-Solid Customer Service
Call 1-800-556-3113
#MSSTR0803

Important Safety Instructions

Before beginning any fitness program, you should obtain a complete physical examination from your physician.

*Il est conseillé de subir un examen médical complet avant d'entreprendre tout programme d'exercice.
Si vous avez des étourdissements ou des faiblesses, arrêtez les exercices immédiatement.*

Antes de comenzar cualquier programa de ejercicios, deberías tener un examen físico con su doctor.

When using exercise equipment, you should always take basic precautions, including the following:

- Read all instructions before using your machine. These instructions are written to ensure your safety and to protect the unit.
- **Do not remove any safety labels from the machine.**
- Do not allow children on or near the equipment.
- Use the equipment only for its intended purpose as described in this guide. Do not use accessory attachments that are not recommended by the manufacturer. Such attachments might cause injuries.
- Wear proper exercise clothing and shoes for your workout, no loose clothing.
- Keep hands, limbs, loose clothing, and long hair well out of the way of all moving parts.
- Use care when getting on or off the unit.
- Do not overexert yourself or work to exhaustion.
- If you feel any pain or abnormal symptoms, stop your workout immediately and consult your physician.
- Never operate unit when it has been dropped or damaged. Return the equipment to a service center for examination and repair.
- Never drop or insert objects into any opening in the equipment.
- **IMPORTANT:** Cables are wear items. It is your responsibility to prevent unexpected breakage. Cable inspection should be performed daily. Inspect all cables, and the area near the fitting at each end of each cable. Replace any damaged or worn cable immediately. Do not allow the machine to be used until these are replaced.

- Do not use the equipment outdoors or near water.

Personal Safety During Assembly

- Before beginning assembly, please take the time to read the instructions thoroughly.
- Read each step in the assembly instructions and follow the steps in sequence. Do not skip ahead. If you skip ahead, you may learn later that you have to disassemble components and that you may have damaged the equipment.
- Assemble and operate your machine on a solid, level surface. Locate the unit a few feet from the walls or furniture to provide easy access.

Your machine is designed for your enjoyment. By following these precautions and using common sense, you will have many safe and pleasurable hours of healthful exercise.

After assembly, you should check all functions to ensure correct operation. If you experience problems, first recheck the assembly instructions to locate any possible errors made during assembly. If you are unable to correct the problem, call the dealer from whom you purchased the machine or call **1-800-556-3113** for the dealer nearest you.

Obtaining Service

Please use your Owner's Manual to make sure that all parts have been included in your shipment. When ordering parts, you must use the part number and description from your Owner's Manual. Use only Body-Solid replacement parts when servicing this machine. Failure to do so will void your warranty and could result in personal injury.

For information about product operation or service, check out the official Body-Solid website at www.bodysolid.com or contact an authorized Body-Solid dealer or a Body-Solid factory-authorized service company or contact Body-Solid customer service at one of the following:

Toll Free: 1-800-556-3113
Phone: 1-708-427-3555
Fax: 1-708-427-3556
Hours: M-F 8:30-5:00 CST
E-Mail: service@bodysolid.com

Or write to: Body-Solid, Inc.
Service Department
1900 S. Des Plaines Ave.
Forest Park, IL 60130 USA

Retain this Owner's Manual for future reference. If you need to order replacement parts please be prepared to provide the following information when contacting us so that we can assist you better.

- 1. Model Number**
- 2. Proof of Purchase**
- 3. Place of Purchase**
- 4. Serial Number (S/N)**
- 5. Part # and Description**

DLAT ASSEMBLY INSTRUCTIONS

HARDWARE ILLUSTRATION

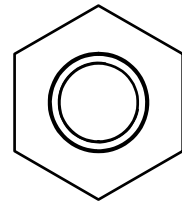
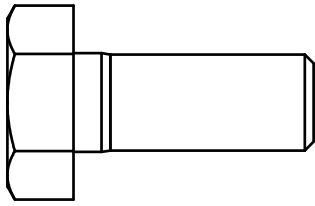

(A1) HEX BOLT 1/2"x1 1/4"L PARTIAL THREAD QTY.2

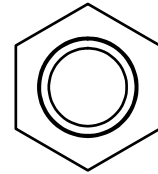
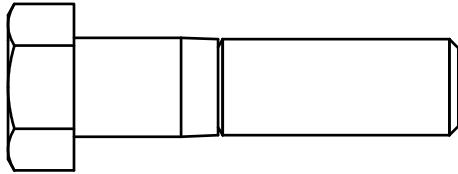

(A2) HEX BOLT 1/2"x2"L PARTIAL THREAD QTY.2

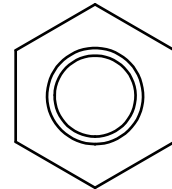
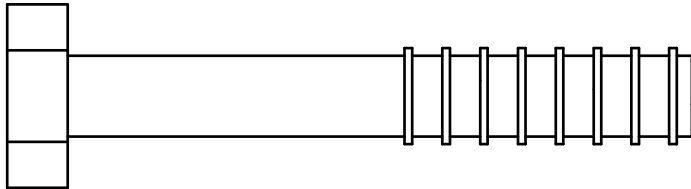

(A3) HEX BOLT 1/2"x3 1/4"L PARTIAL THREAD QTY.1

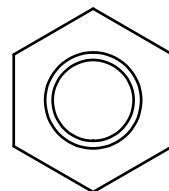
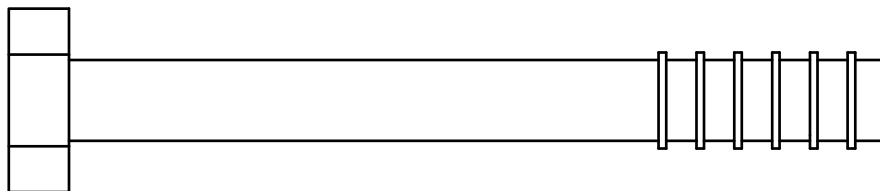

(A4) HEX BOLT 1/2"x4 1/4"L PARTIAL THREAD QTY.2

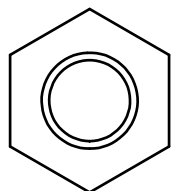
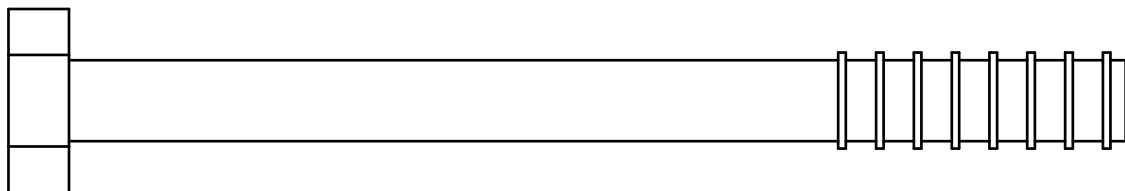

(A5) HEX BOLT 1/2"x5 1/2"L PARTIAL THREAD QTY.3

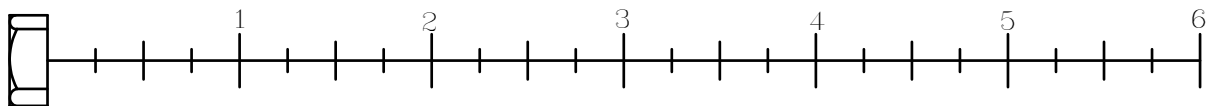

DLAT ASSEMBLY INSTRUCTIONS

HARDWARE ILLUSTRATION

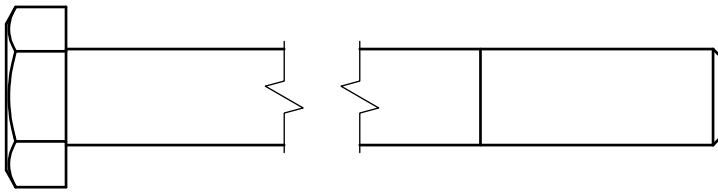

(A6)HEX BOLT 1/2"x5 3/4"L PARTIAL THREAD QTY.1

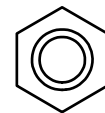
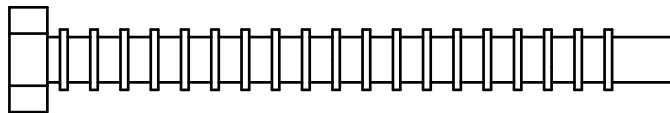

(A9)HEX BOLT 5/16"x3 1/4"L PARTIAL THREAD QTY.2

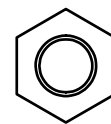
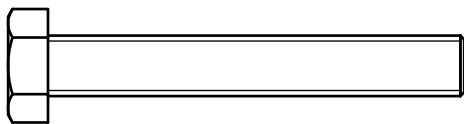

(A22)HEX BOLT M8x55L PARTIAL THREAD QTY.1

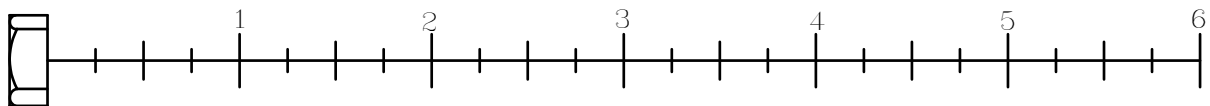

DLAT ASSEMBLY INSTRUCTIONS

HARDWARE ILLUSTRATION CONNECT DGYM

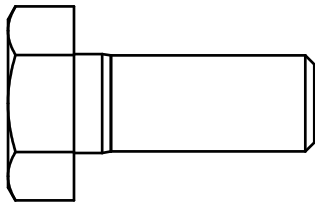

(A10)HEX BOLT 1/2"x1 1/4"L PARTIAL THREAD QTY.4

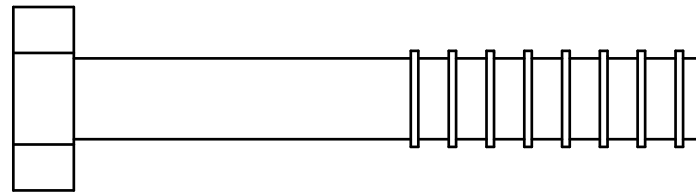
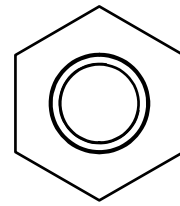

(A11)HEX BOLT 1/2"x3 1/4"L PARTIAL THREAD QTY.1

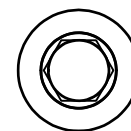
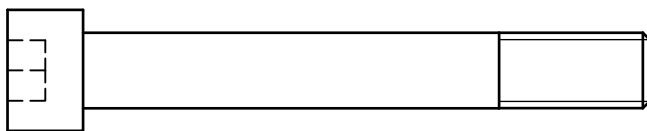
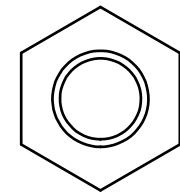

(A21)ROUND ALLEN HEAD M10X75L PARTIAL THREAD QTY.2

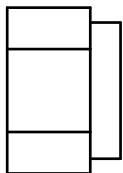

(B1)NYLON LOCK NUT 1/2" QTY.5

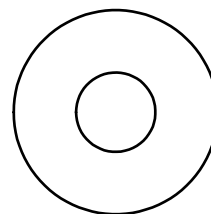
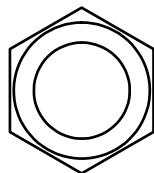

(C12)M10(I.D.)FLAT WASHER Ø27 QTY.2

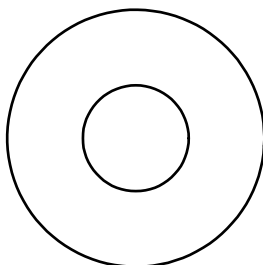

(C1)1/2"(I.D.)FLAT WASHER Ø34 QTY.10

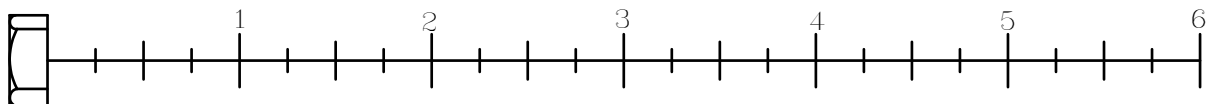

DLAT ASSEMBLY INSTRUCTIONS

FRAME HARDWARE ILLUSTRATION

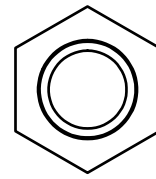
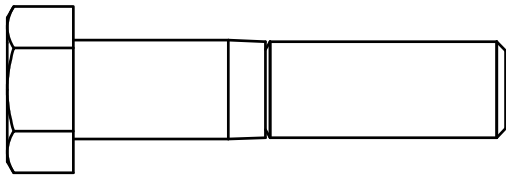

(A13)HEX BOLT 1/2"x2 1/4"L PARTIAL THREAD QTY.1

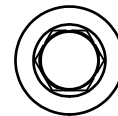
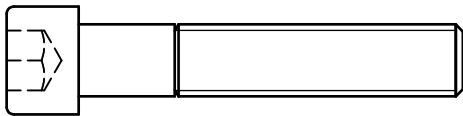

(A15)ROUND ALLEN HEAD 3/8"X2"L PARTIAL THREAD QTY.1

Optional Purchase

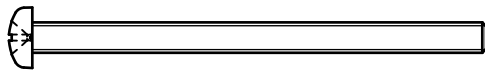

(A14)HEX BOLT M4X65"L PARTIAL THREAD QTY.2

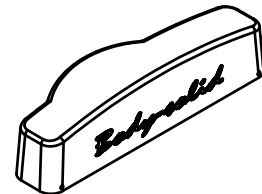

TOP CAP(9211-111)

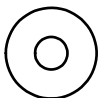

(C10)M4(I.D.)FLAT WASHER Ø12 QTY.2

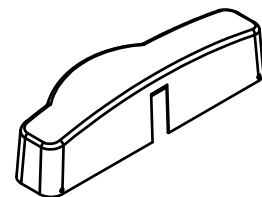

TOP CAP(9211-119)

"M4X65 ROUND BOLT" and "M4 WASHER" is used to assemble with 9211-111 and 9211-119 TOP CAP

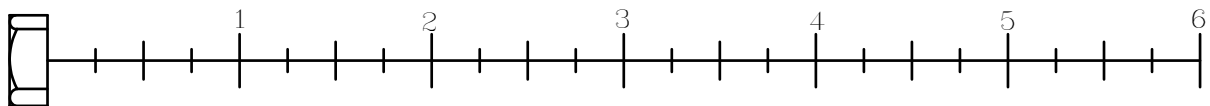

DLAT ASSEMBLY INSTRUCTIONS

FRAME HARDWARE ILLUSTRATION

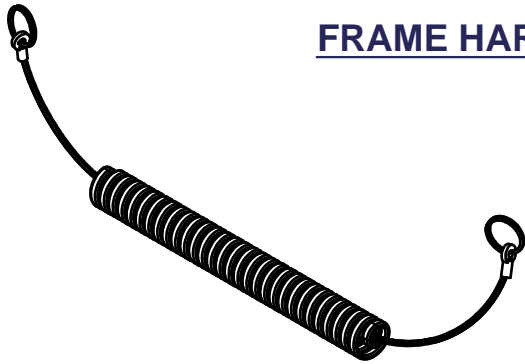

(A16)ELASTIC BOLT QTY.1

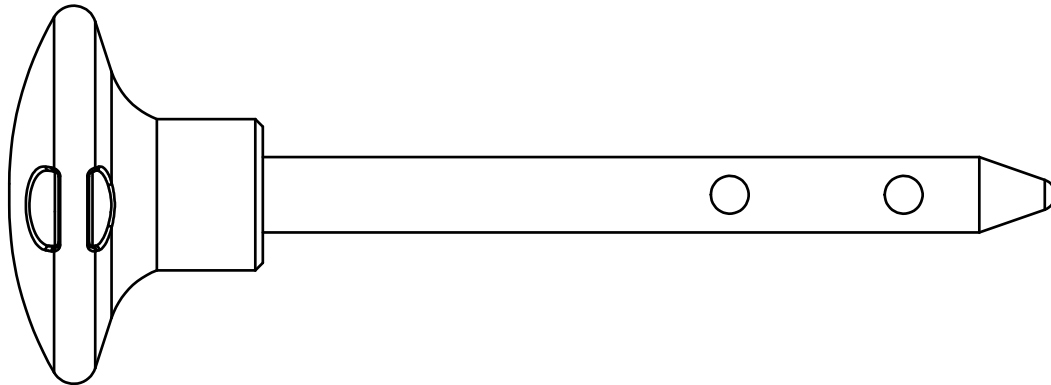

(A17)10LB PIN (8250-071) QTY.1



(A19)ROUND ALLEN HEAD M6X20L PARTIAL THREAD QTY.24



(A20)ROUND ALLEN HEAD 5/32"X1/4"L PARTIAL THREAD QTY.4

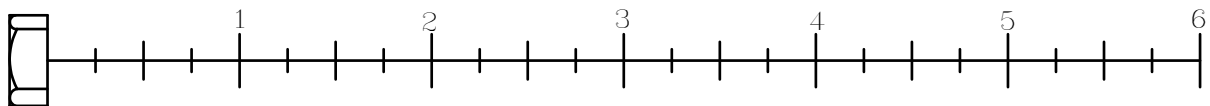

DLAT ASSEMBLY INSTRUCTIONS

HARDWARE ILLUSTRATION

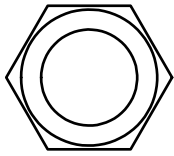

(B2) NYLON LOCK NUT 1/2" QTY.10

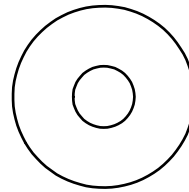
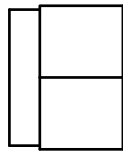

(C5) 5/16" (I.D.) FLAT WASHER Ø24 QTY.4



(B7) NYLON LOCK NUT M8 QTY.1

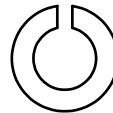

(C6) 5/16" SPRING WASHER QTY.2

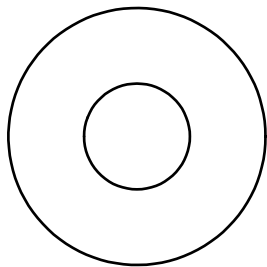

(C3) 1/2" (I.D.) FLAT WASHER Ø34 QTY.17

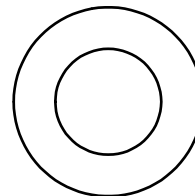
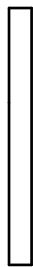

(C13) 1/2" (I.D.) FLAT WASHER Ø25 QTY.4

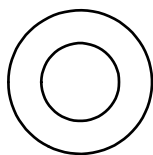

(C4) 3/8" (I.D.) FLAT WASHER Ø19 QTY.2

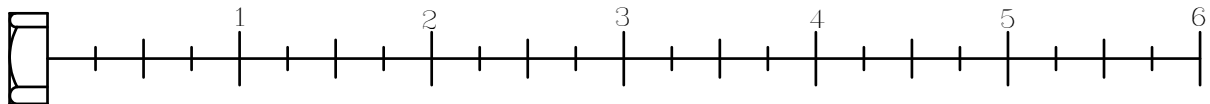

DLAT ASSEMBLY INSTRUCTIONS

FRAME HARDWARE ILLUSTRATION

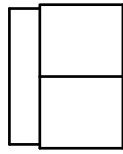
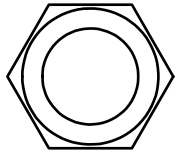

(B5)NYLON LOCK NUT 1/2" QTY.1

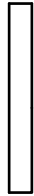
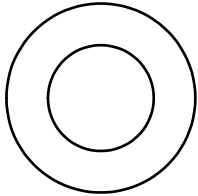

(C8)1/2"(I.D.)FLAT WASHER Ø25 QTY.2

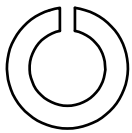

(C9)3/8" SPRING WASHER QTY.1

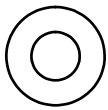

(C11)M6(I.D.)FLAT WASHER Ø13 QTY.24

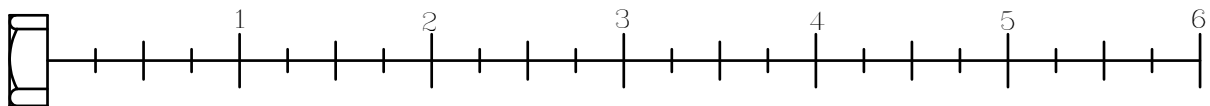

DLAT ASSEMBLY INSTRUCTIONS

Selector Rod HARDWARE ILLUSTRATION

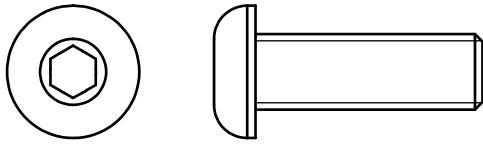

(A22)ROUND ALLEN HEAD M10X30L PARTIAL THREAD QTY.1

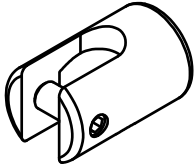

(A23)FIRM SHEATH(8890-046) QTY.1

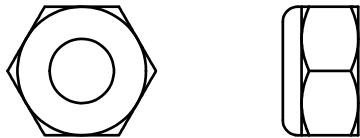

(B6)NYLON LOCK NUT M10 QTY.1

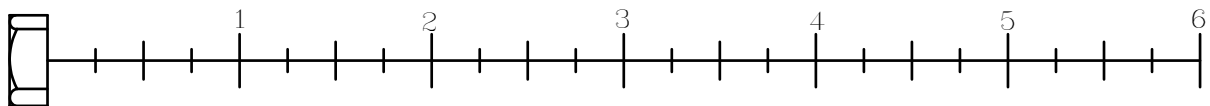

DLAT ASSEMBLY INSTRUCTIONS

HARDWARE ILLUSTRATION

D1.Ø3/4"X16L STEEL BUSHING (8110-066)	[2PCS]
D2.Ø3/4"X45L STEEL BUSHING (8110-067)	[8PCS]
D3.Ø1" SHAFT COLLAR(8130-024)	[2PCS]
D4.Ø8 SPRING SNAP LINK(8810-001)	[2PCS]
D5.Ø1" END CAP(9211-016)	[2PCS]
D6.Ø60 END CAP(9211-065)	[2PCS]
D7.50X100(40X80)NYLON BUSHING(9211-107)	[2PCS]
D8.58X116X2.5T FOOT CAP(9211-108)	[2PCS]
D9.COVER(9211-110)	[2PCS]
D10.58X116 END CAP(9211-112)	[2PCS]
D11.40X80 END CAP(9211-113)	[2PCS]
D12. 3" Nylon Washer (9214-008)	[4PCS]
D13. Ø1"x2.5t Round End Cap(9260-021)	[2PCS]
D14.Ø3/4" SHAFT COLLAR(9211-046)	[2PCS]
D15.Ø2 1/2"X19.2X19.4T RUBBER DOUNT(9310-010)	[2PCS]
D16.95X140L RUBBER PAD(9310-035)	[2PCS]
D17.95X250 RUBBER PAD(9310-060)	[2PCS]

D1



D2

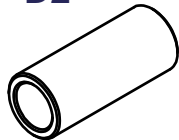

D3



D4



D5

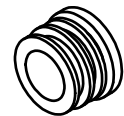

D6

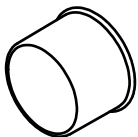

D7

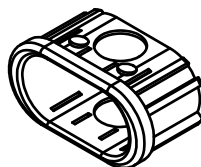

D8

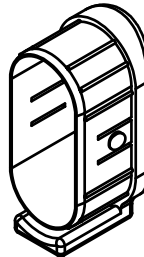

D9

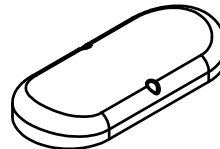

D10

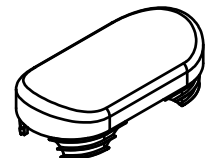

D11

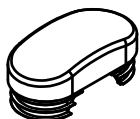

D12



D13

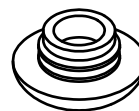

D14



D15

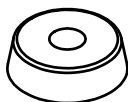

D16

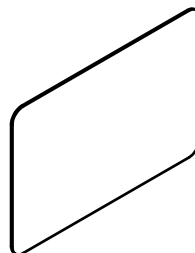

D17

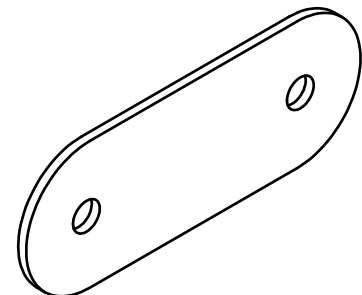

DLAT ASSEMBLY INSTRUCTIONS

HARDWARE ILLUSTRATION

D18.Ø117 PULLEY(9213-010B)-----	[8PCS]
D19.TOP PLATE(8400-006)-----	[1PCS]
D21.1975mm STEEEL CABLE(FDLATA)-----	[1PCS]
D22.3250mm STEEL CABLE(FDLATB)-----	[1PCS]
D23.DLAT For DGYM Steel Cable(FDLATC)-----	[1PCS]
D24.150X250L RUBBER PAD(9310-036)-----	[2PCS]
D25.WEIGHT SELECTOR BAR(8210-042B)-----	[1PCS]

D18

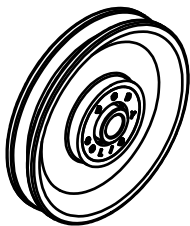

D19

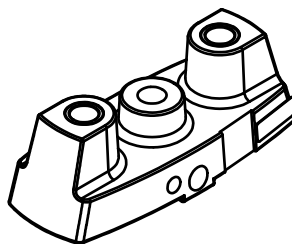

D21

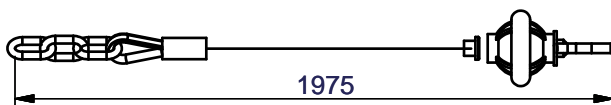

D22

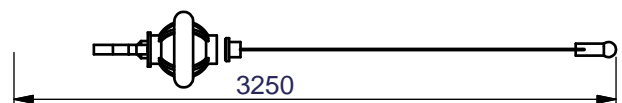

D24

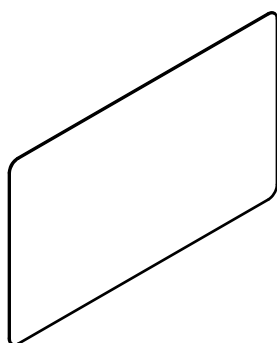

D25

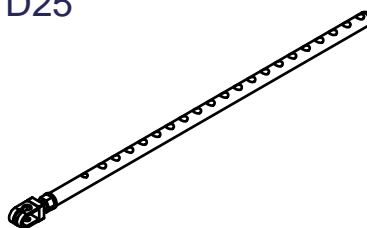

DLAT ASSEMBLY INSTRUCTIONS

PARTS ILLUSTRATION SHEET

A2[1PCS]

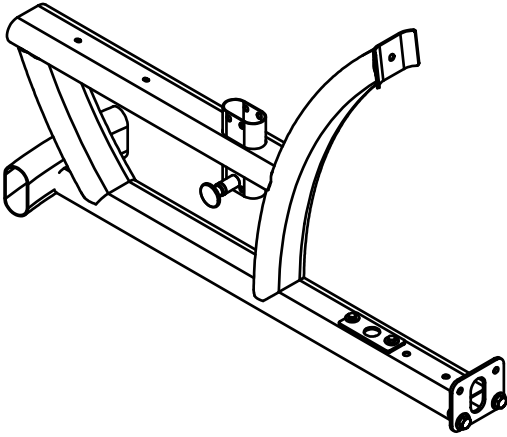

B[1PCS]

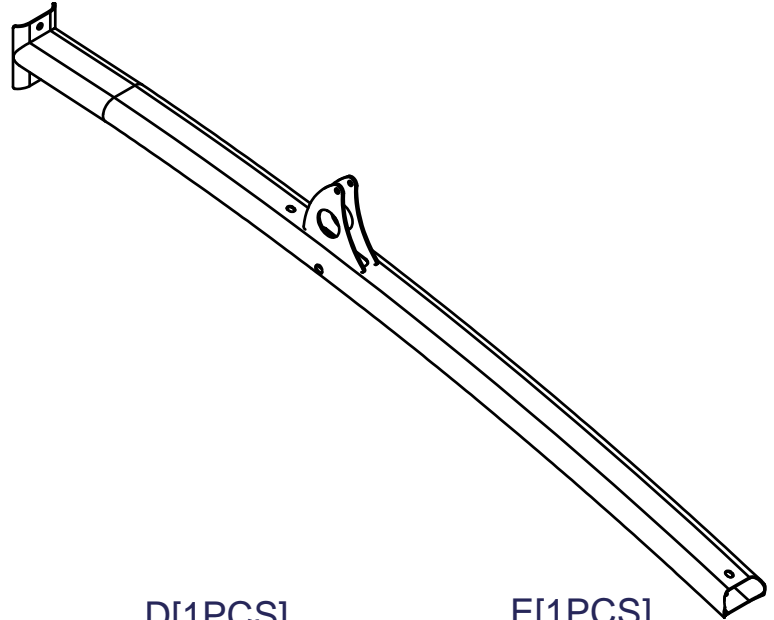

C[1PCS]

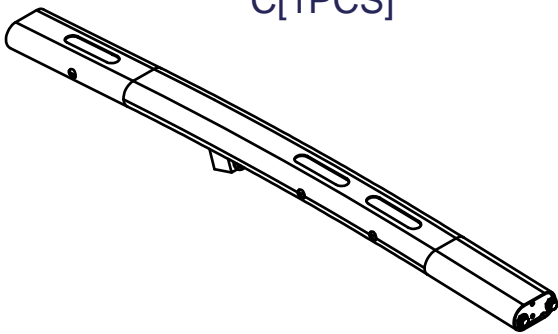

D[1PCS]

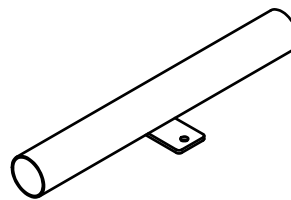

E[1PCS]

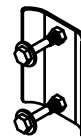

F[1PCS]

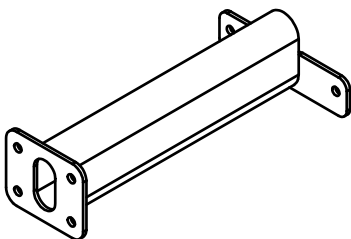

G[1PCS]
CONNECT DGM

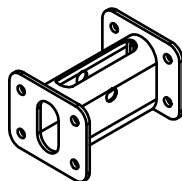

H[2PCS]

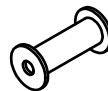

I[1PCS]

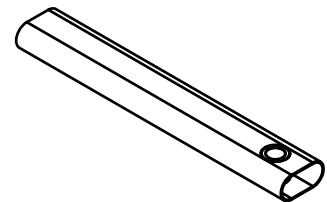

J[1PCS]
Ø1"X600L

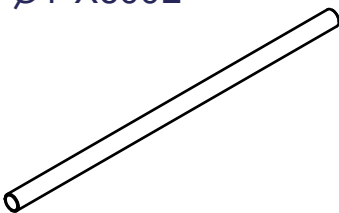

K[1PCS]
20LB1200D

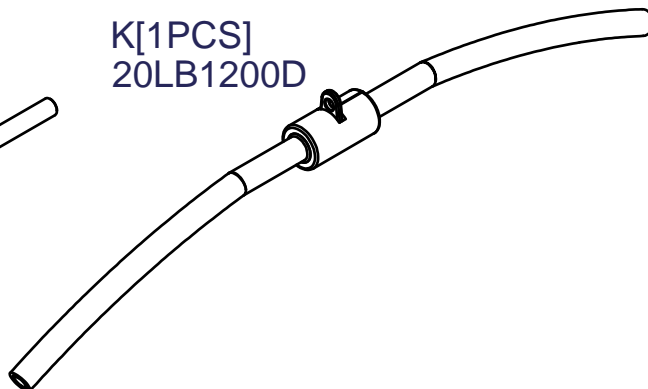

L[1PCS]
8313-130

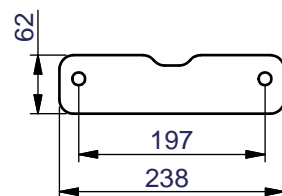

DLAT ASSEMBLY INSTRUCTIONS

PARTS ILLUSTRATION SHEET

M[1PCS]
8343-146

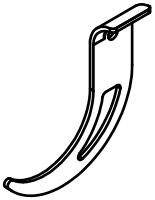

N[1PCS]
8343-147



O[2PCS]
8343-140

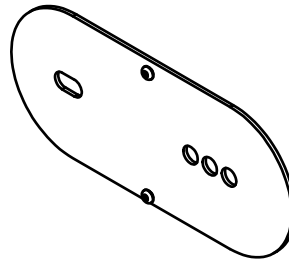

P[1PCS]
8290-001

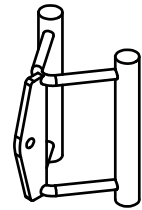

Q[1PCS]
9121-054

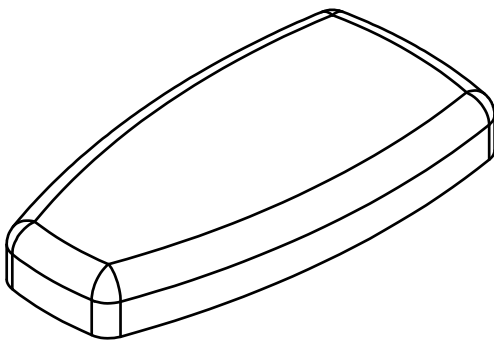

R[2PCS]
9161-021
Ø150X250L

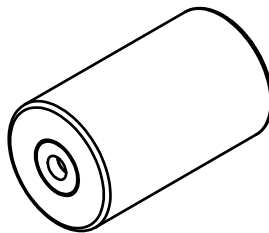

DLAT ASSEMBLY INSTRUCTIONS

FRAME PARTS ILLUSTRATION SHEET

S[1PCS]
6610-001

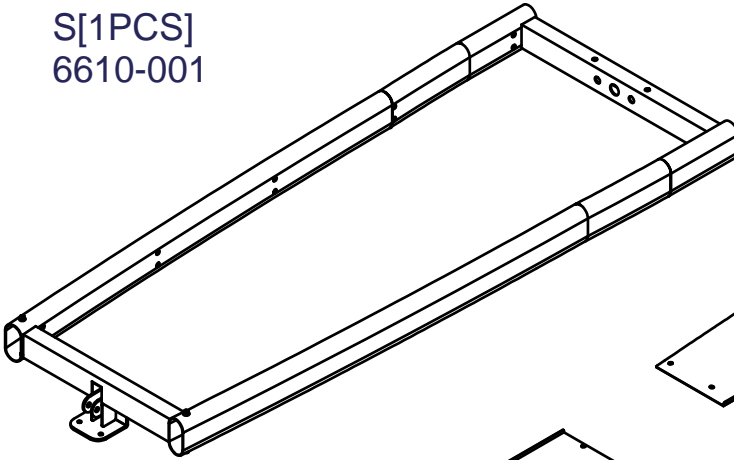

T[1PCS]
8380-044

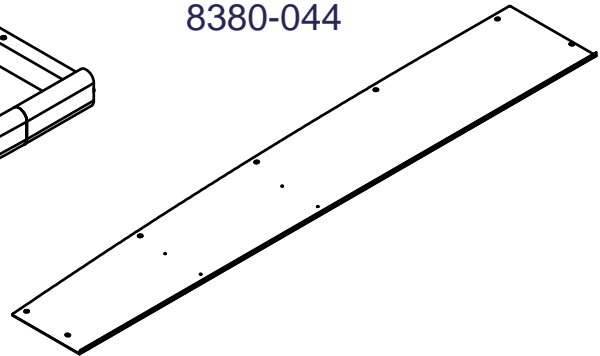

U[1PCS]
8380-052

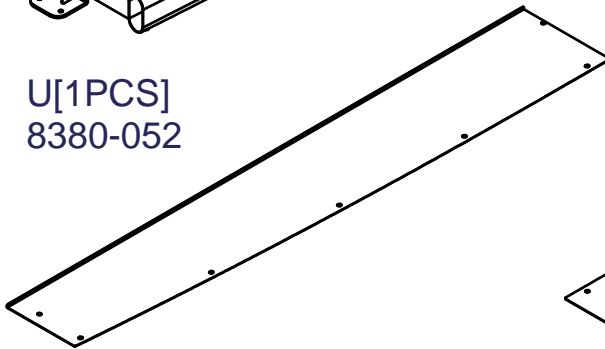

V[1PCS]
8380-045

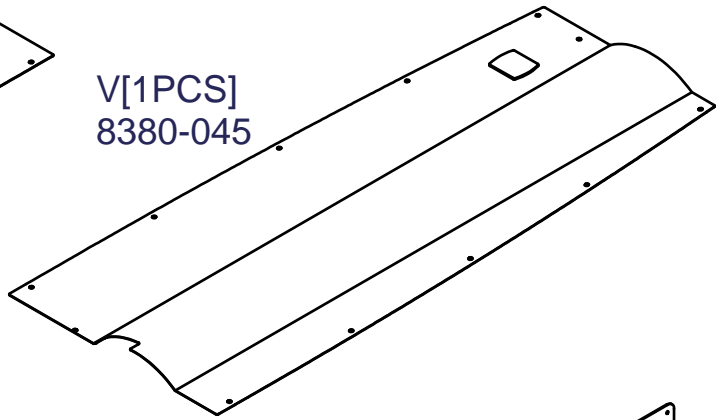

W[2PCS]
Ø3/4"X1932L

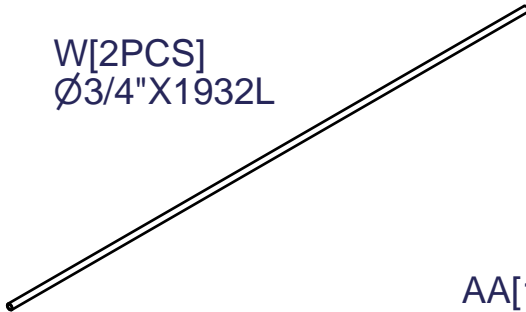

Z[1PCS]
9440-165

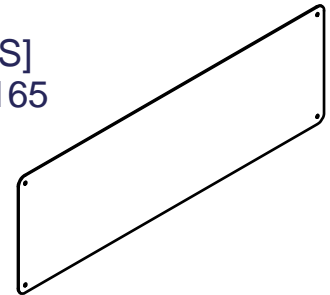

AC[1PCS]
9211-119A

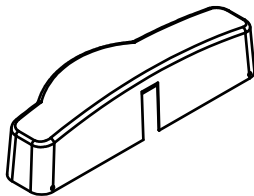

AA[12PCS]
8321-040
both side

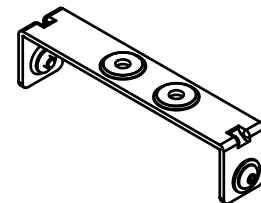
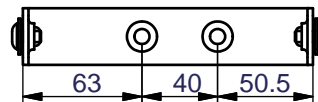

AB[2PCS]
8321-040
one side

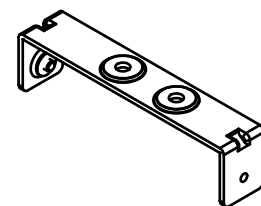
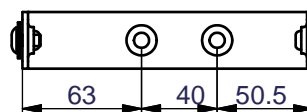

Y[2PCS]
8313-144

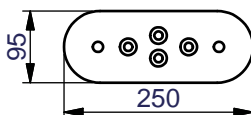

DLAT ASSEMBLY INSTRUCTIONS

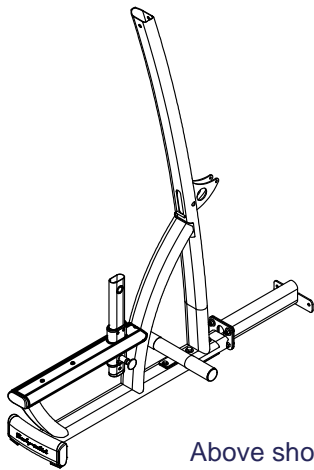

Above shows STEP 2
assembled and completed

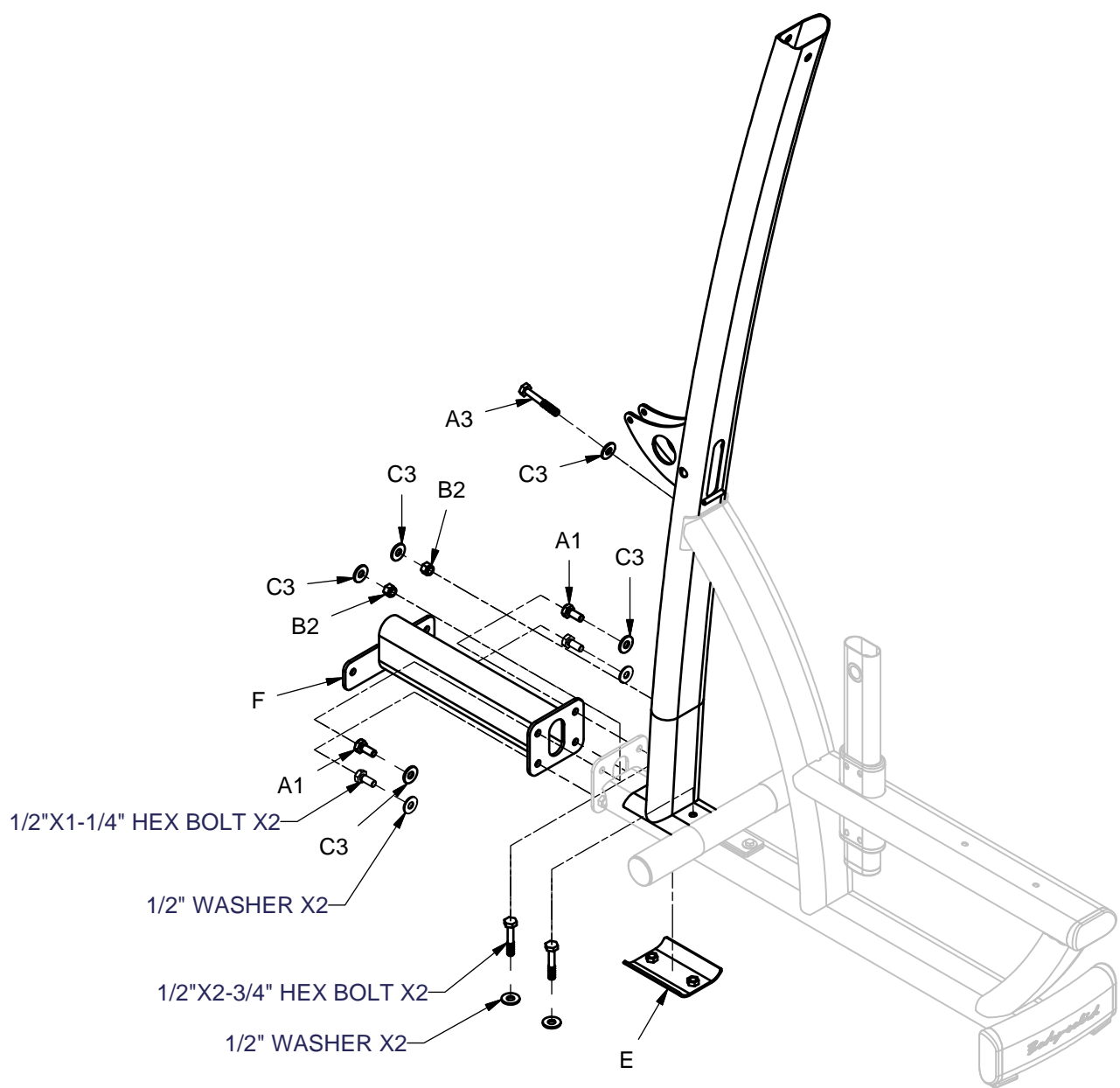

DLAT ASSEMBLY INSTRUCTIONS

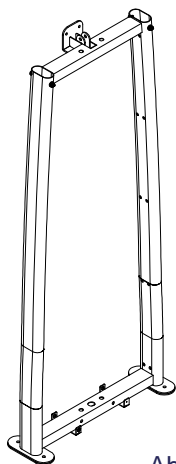

Above shows STEP 3
assembled and completed

DLAT single weight stack assembly instructions

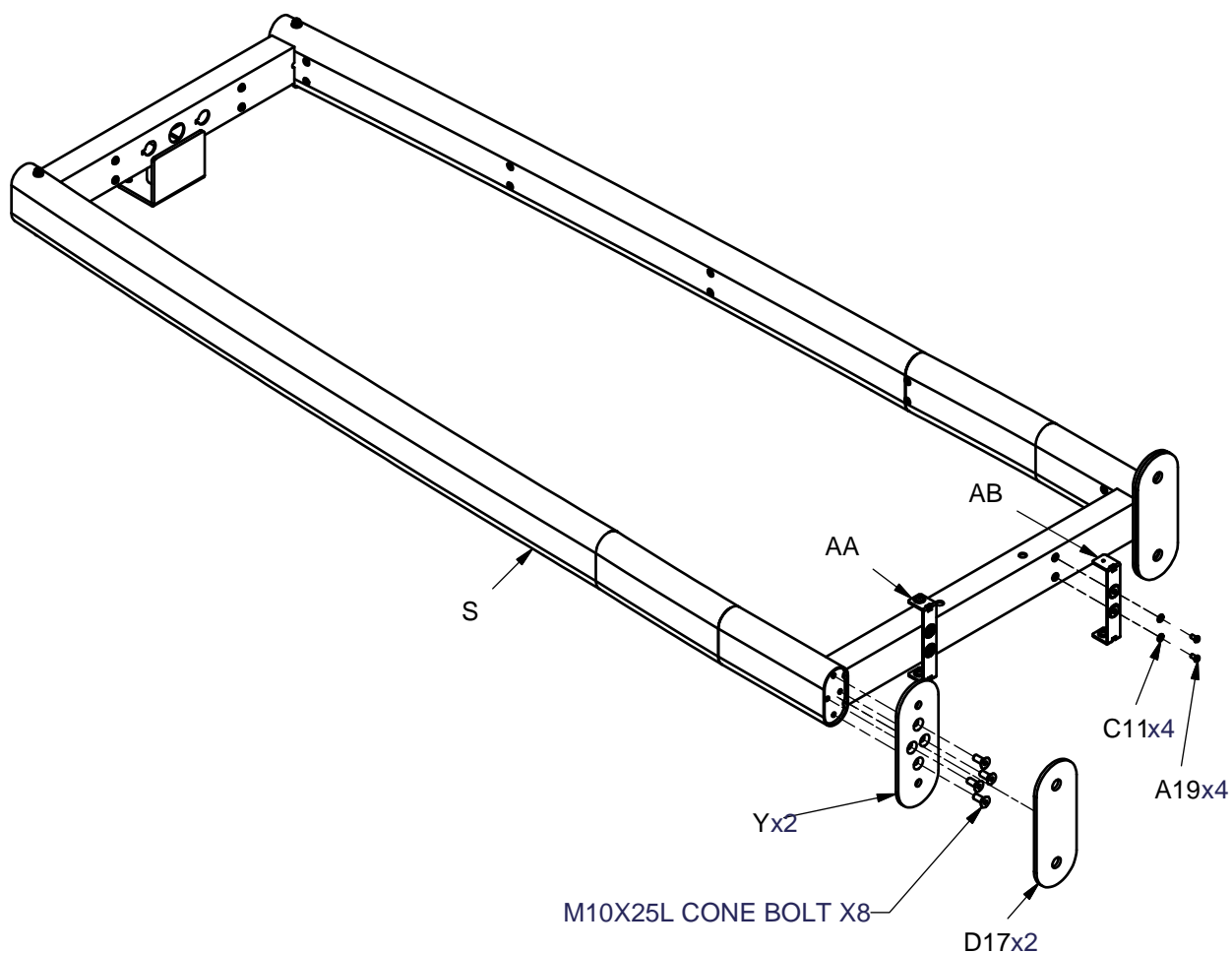

DLAT ASSEMBLY INSTRUCTIONS

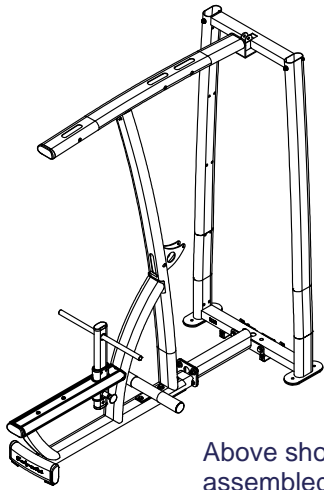

Above shows STEP 4 assembled and completed

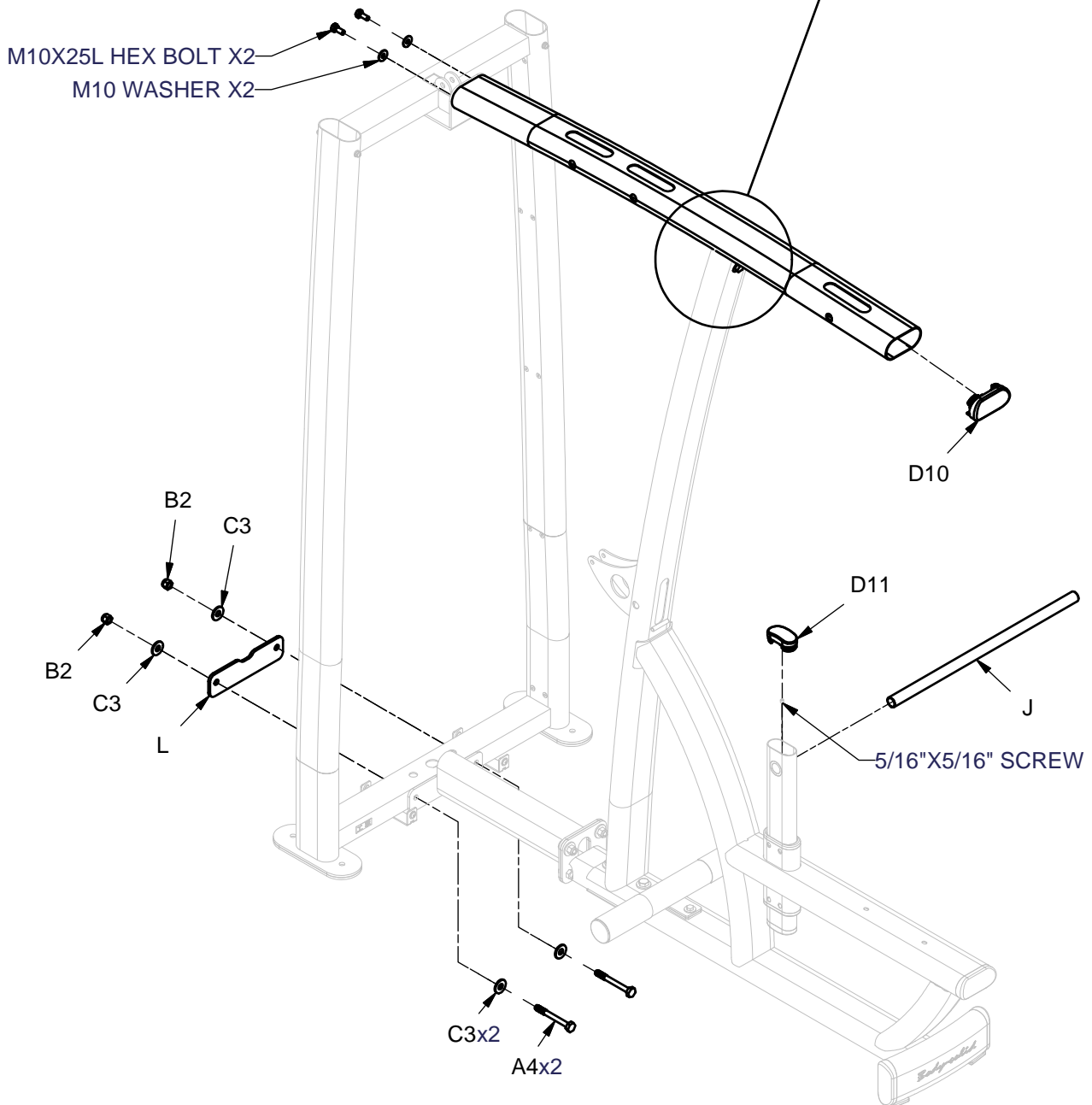
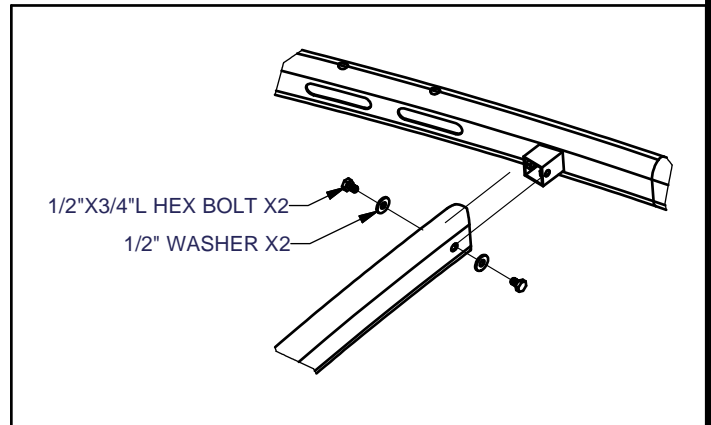

DLAT ASSEMBLY INSTRUCTIONS

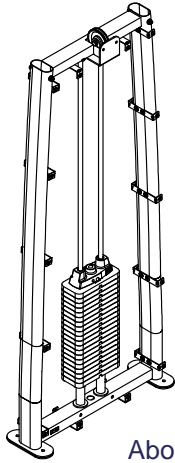

Above shows STEP 5 assembled and completed

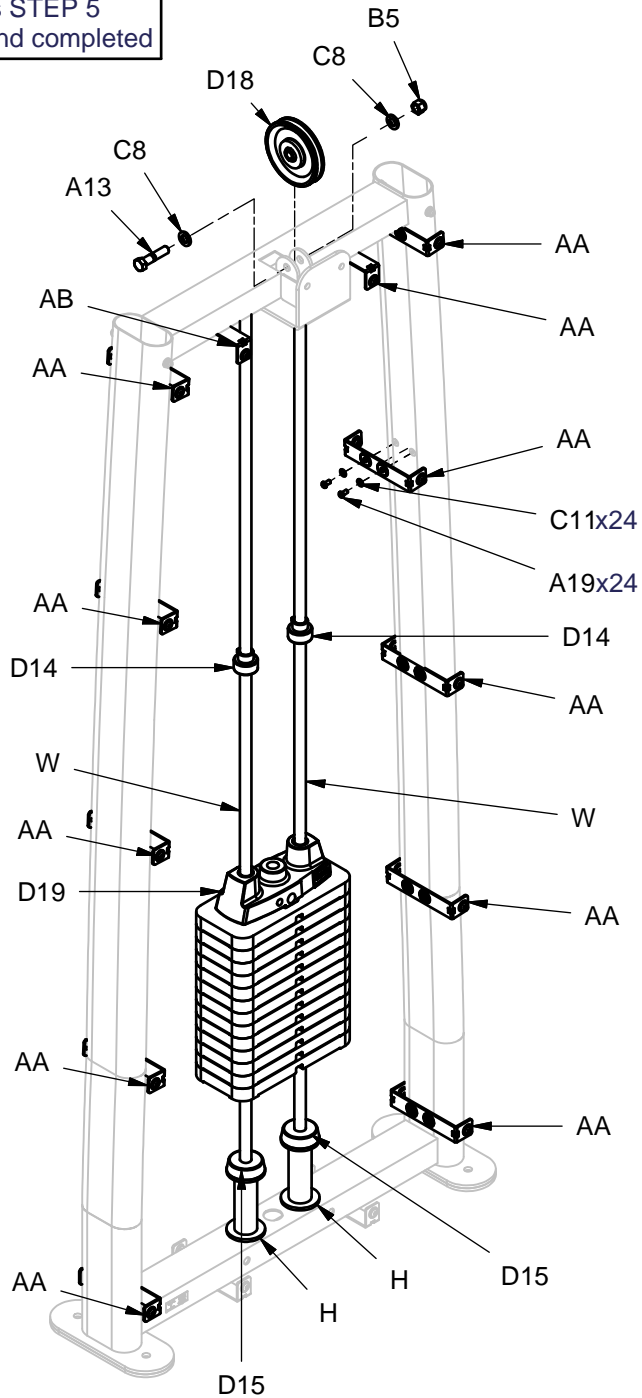

DLAT ASSEMBLY INSTRUCTIONS

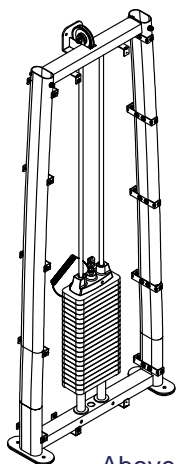

Above shows STEP 6
assembled and completed

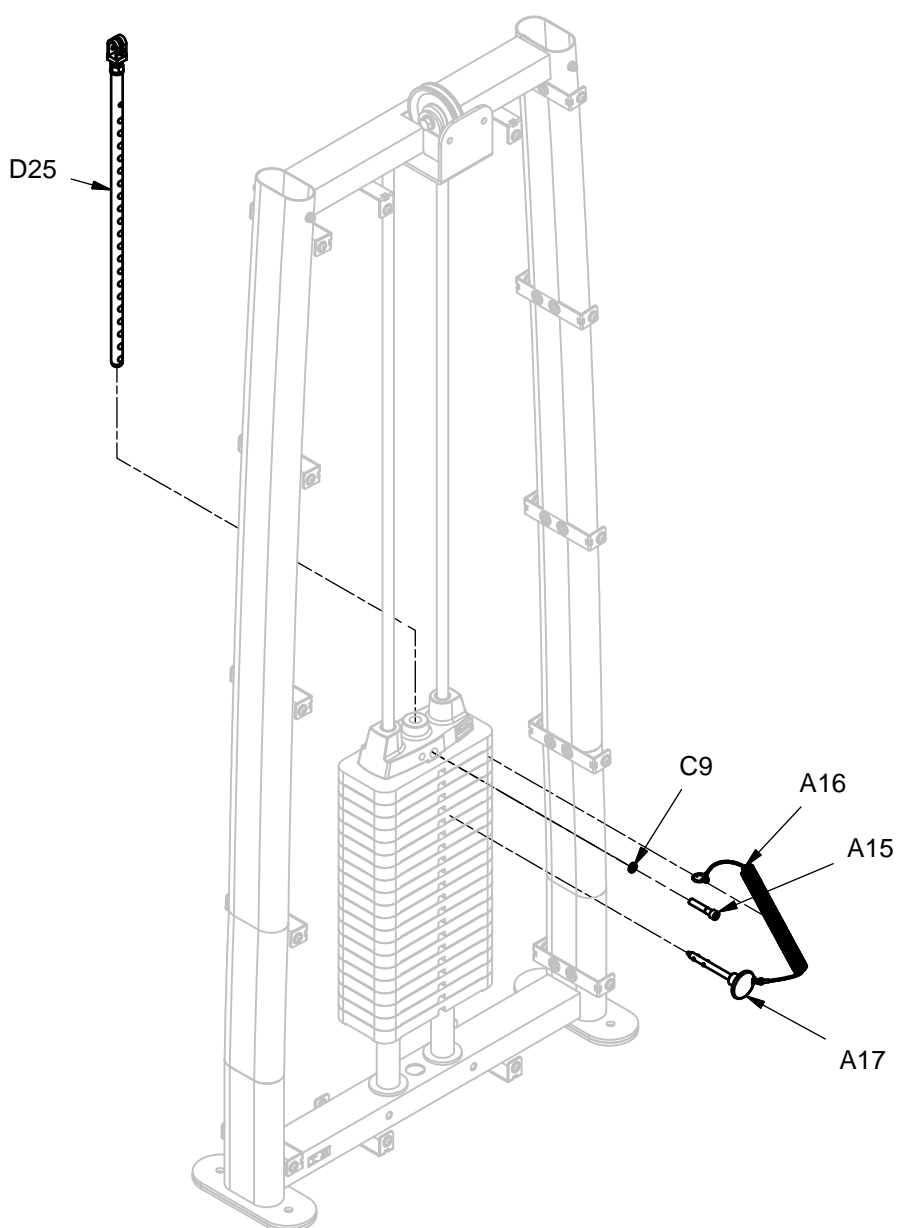

DLAT ASSEMBLY INSTRUCTIONS

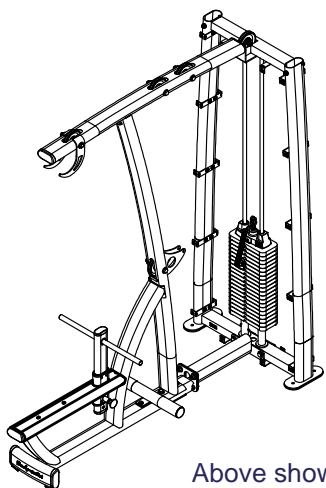

Above shows STEP 7 assembled and completed

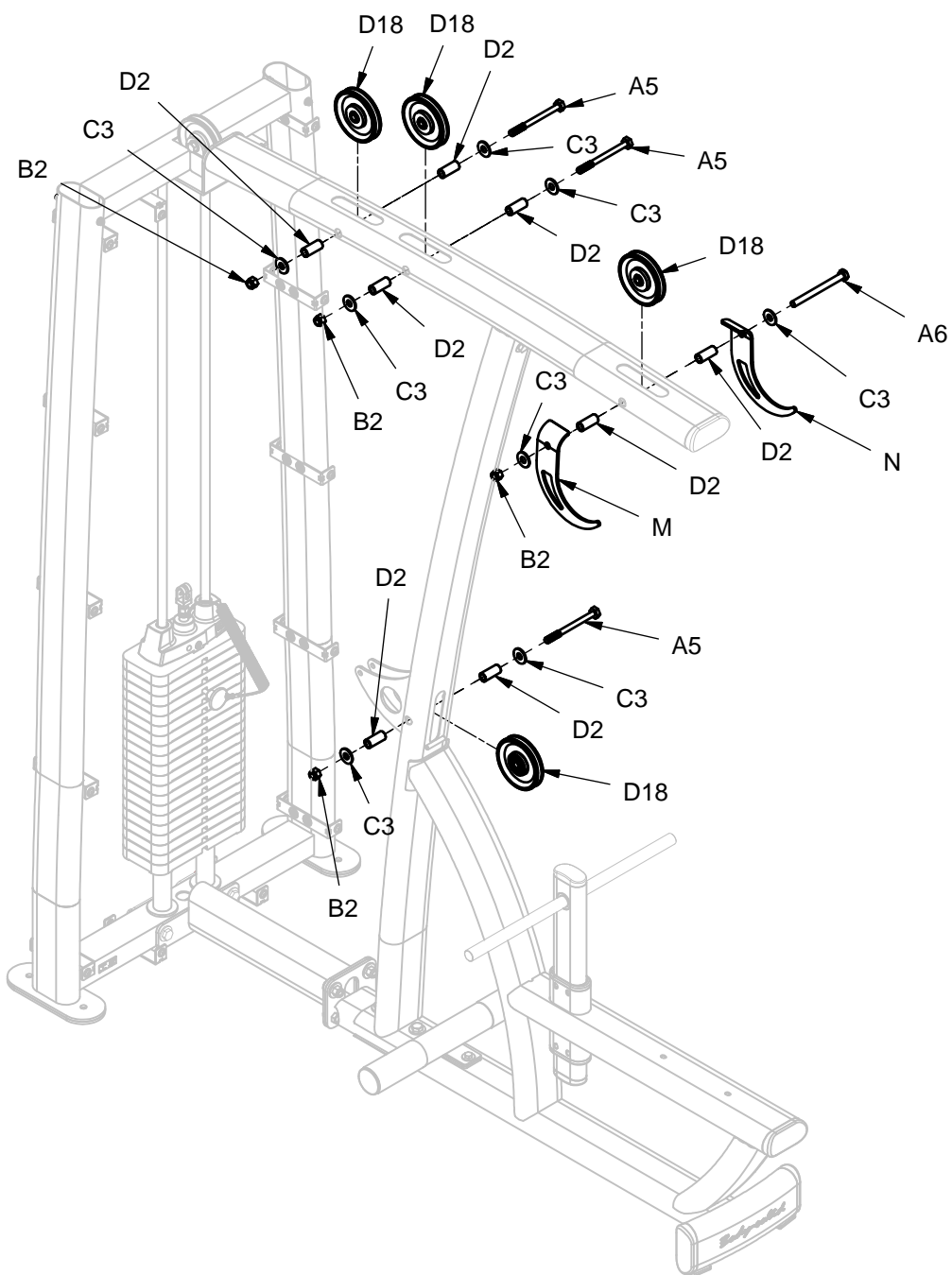

DLAT ASSEMBLY INSTRUCTIONS

Cable to match illustration

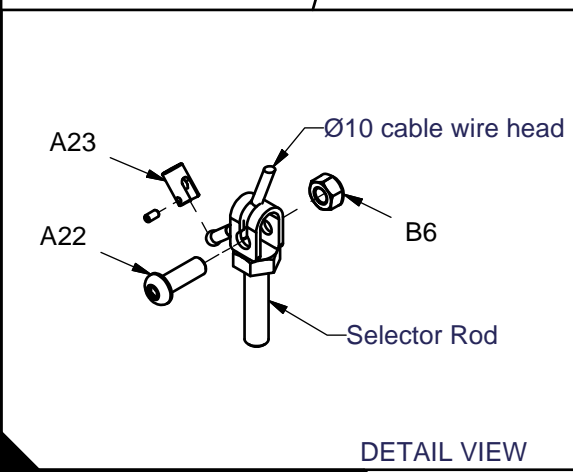
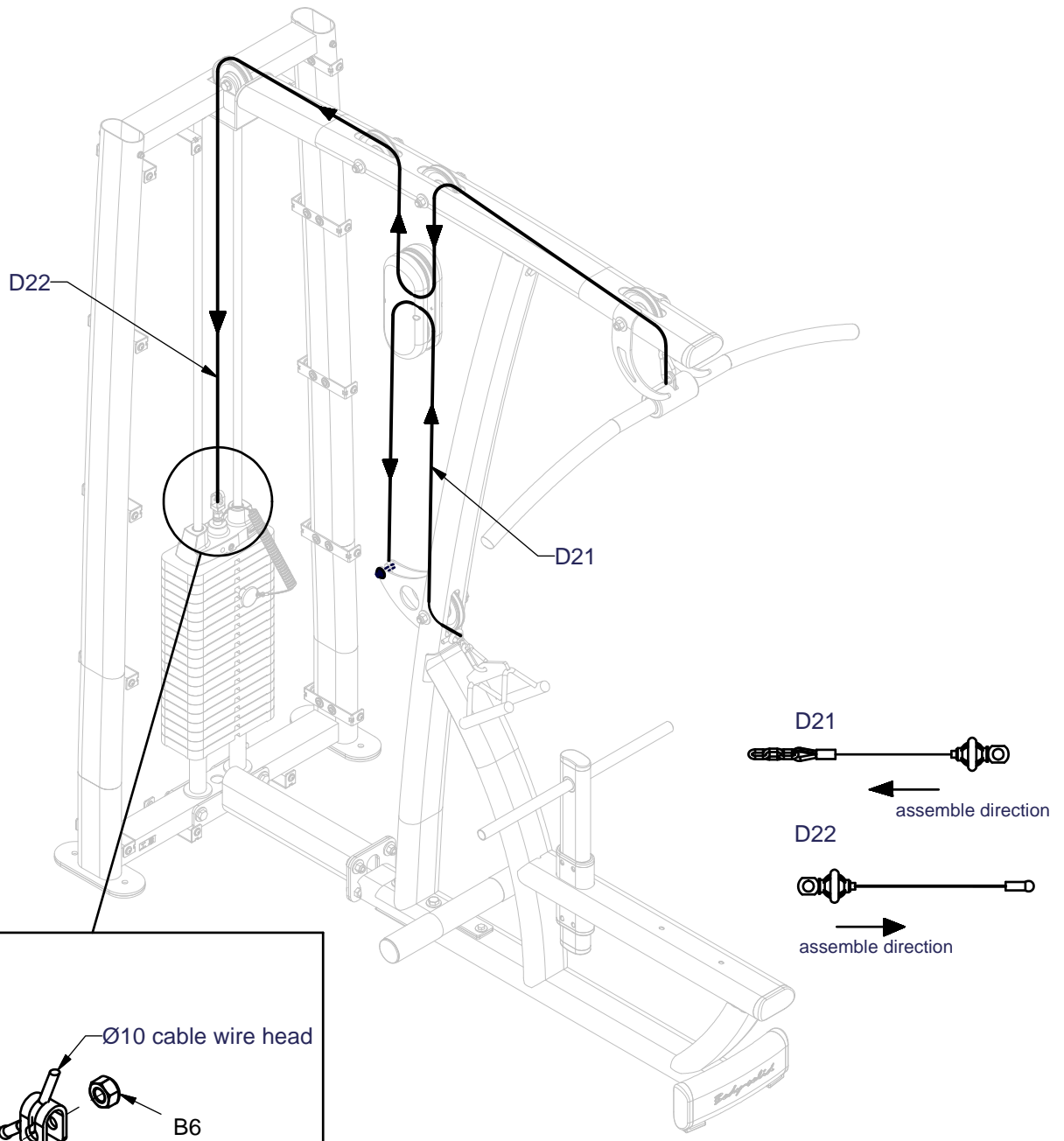

DLAT ASSEMBLY INSTRUCTIONS

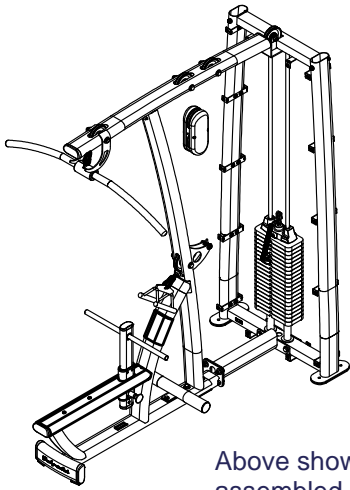

Above shows STEP 8 assembled and completed

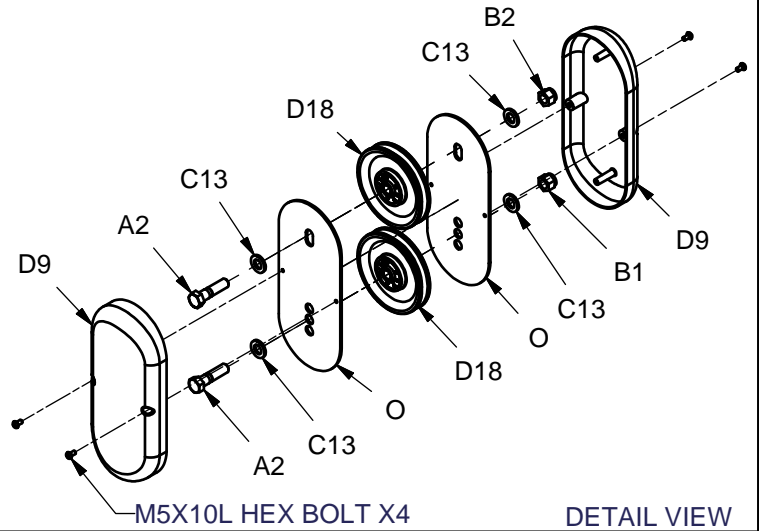

M5X10L HEX BOLT X4

DETAIL VIEW

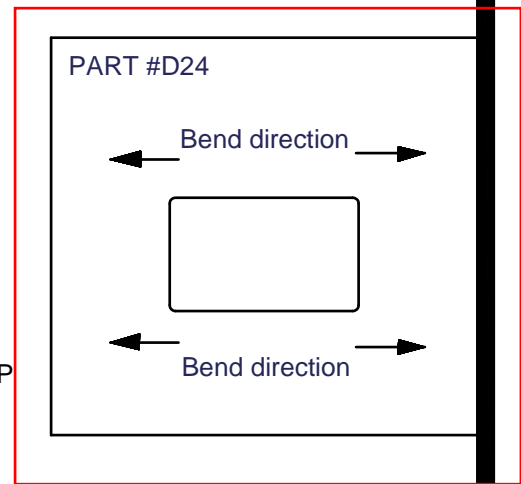
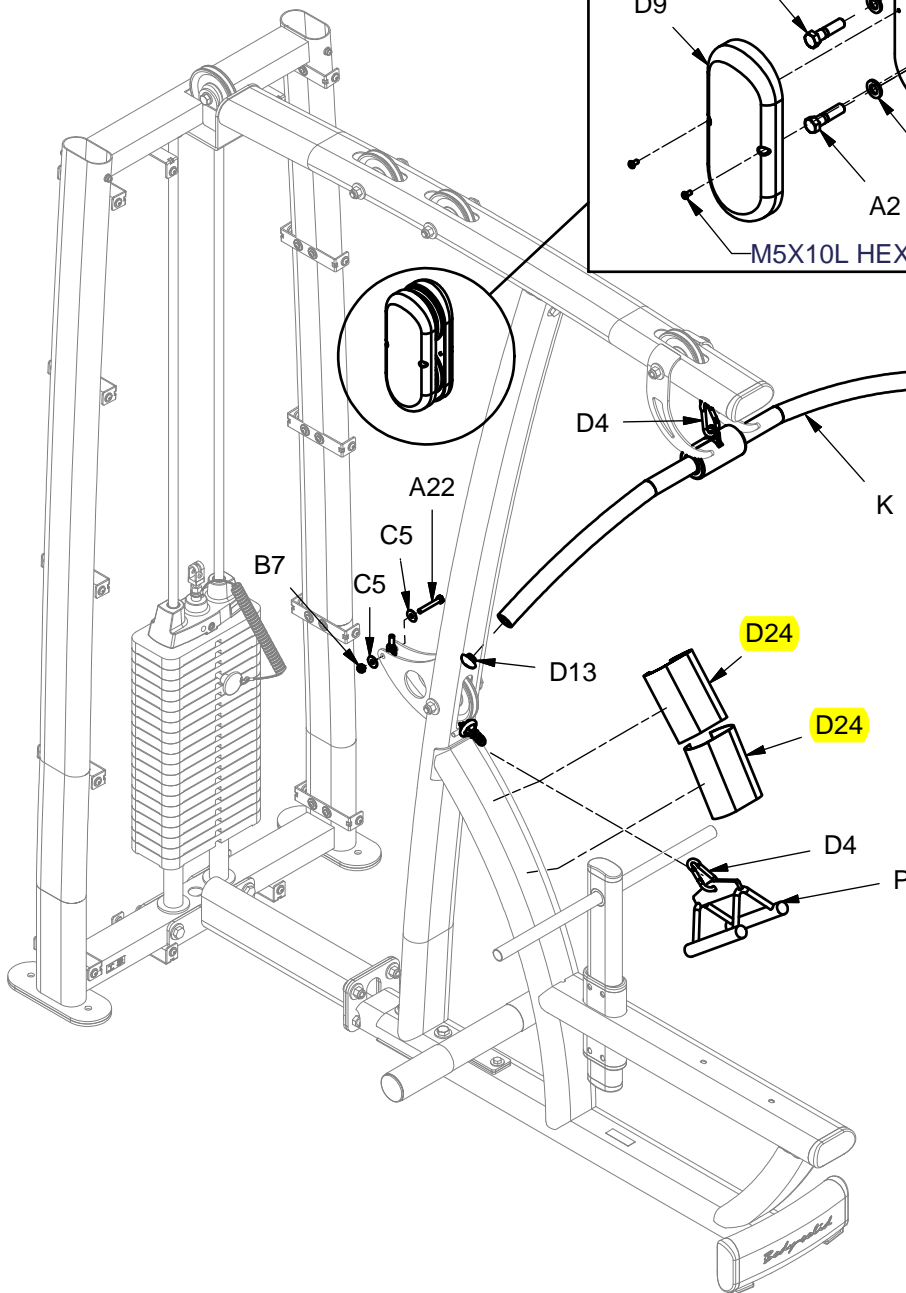

DLAT ASSEMBLY INSTRUCTIONS

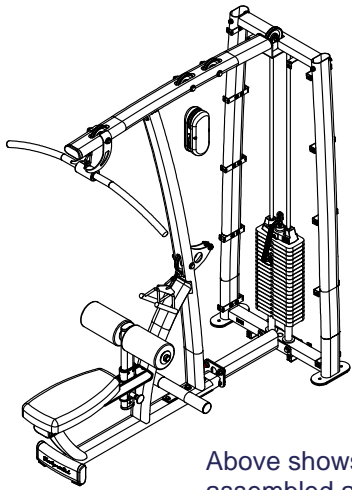

Above shows STEP 9 assembled and completed

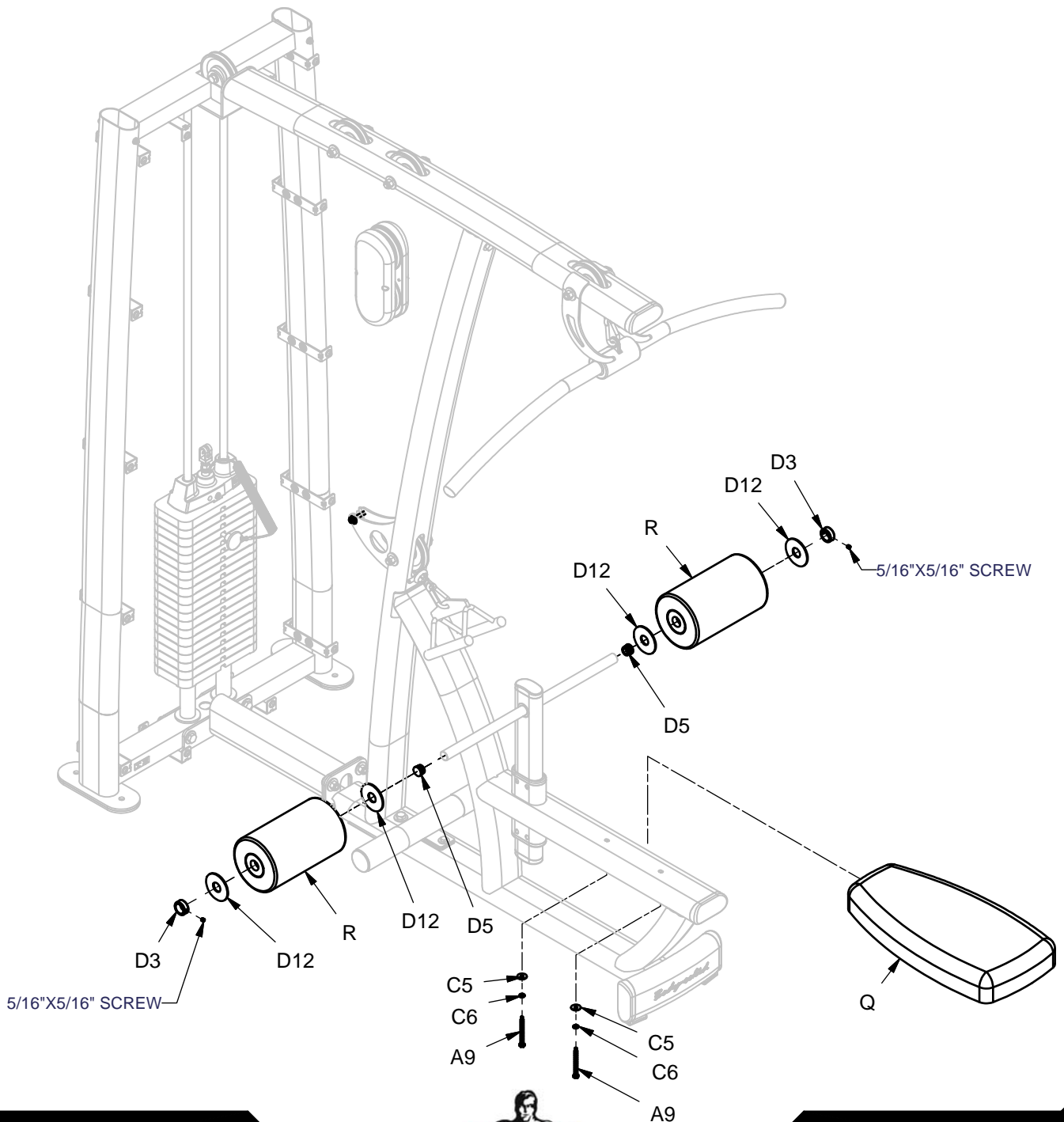

DLAT ASSEMBLY INSTRUCTIONS

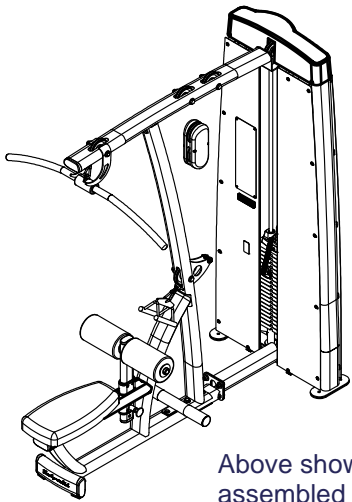

Above shows STEP 10 assembled and completed

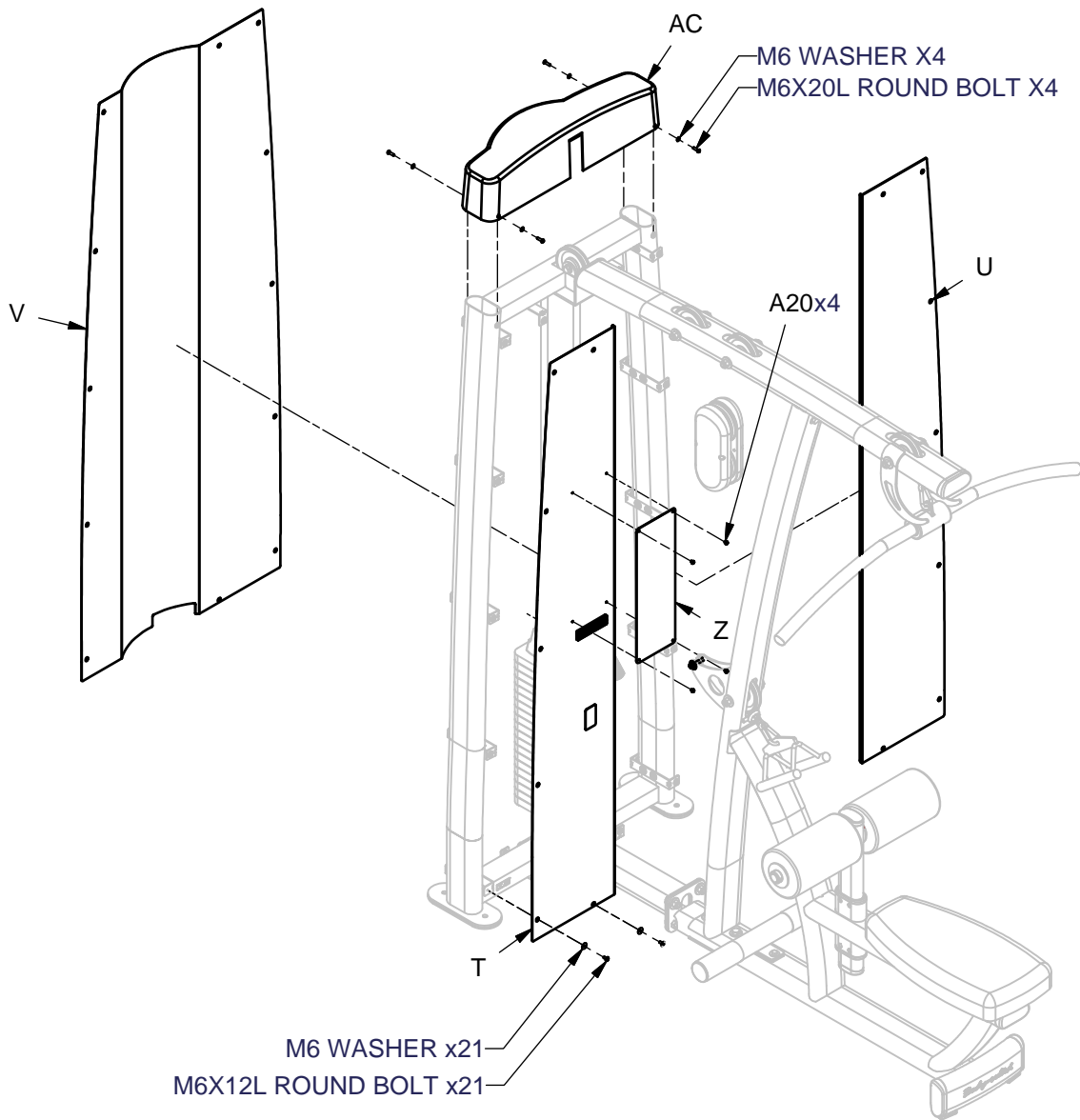

DLAT ASSEMBLY INSTRUCTIONS

Cable to match illustration

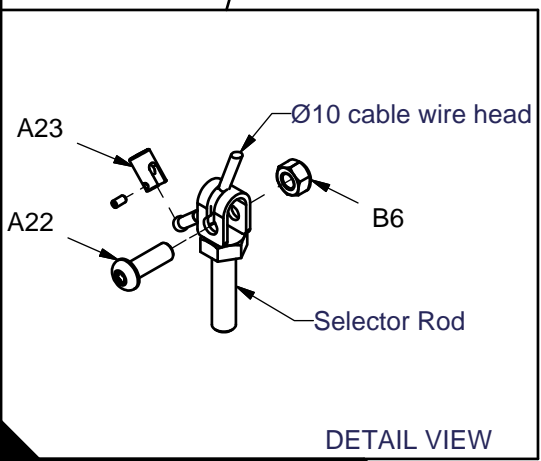
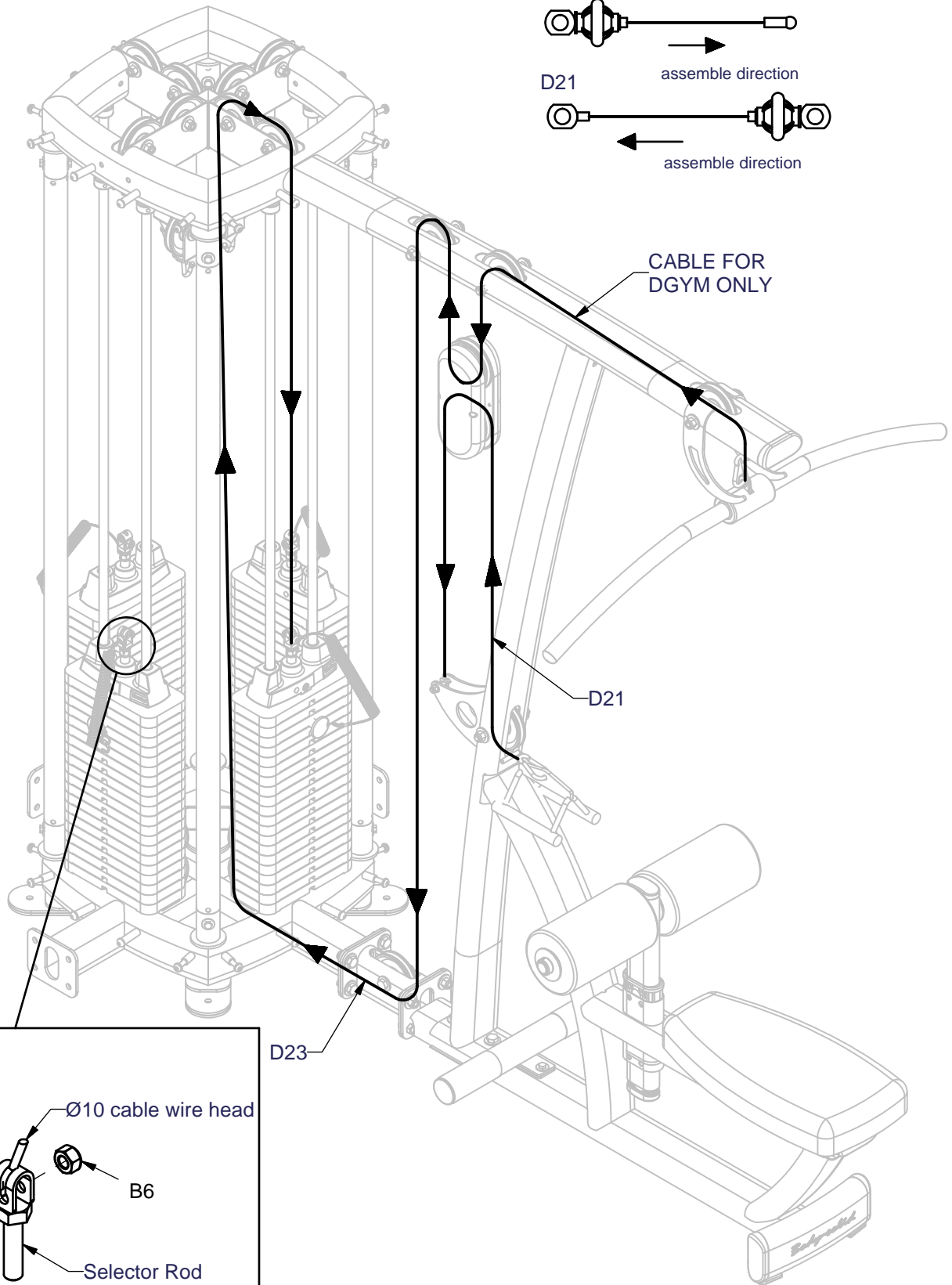
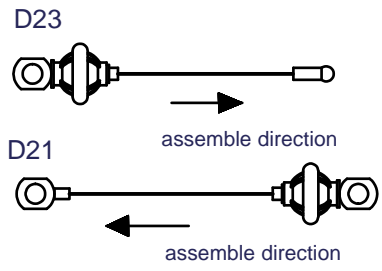

DLAT ASSEMBLY INSTRUCTIONS

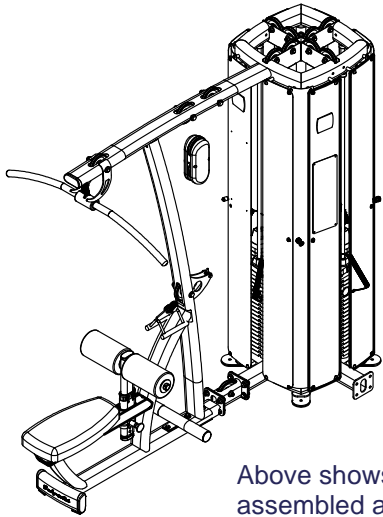

Above shows STEP 11 assembled and completed

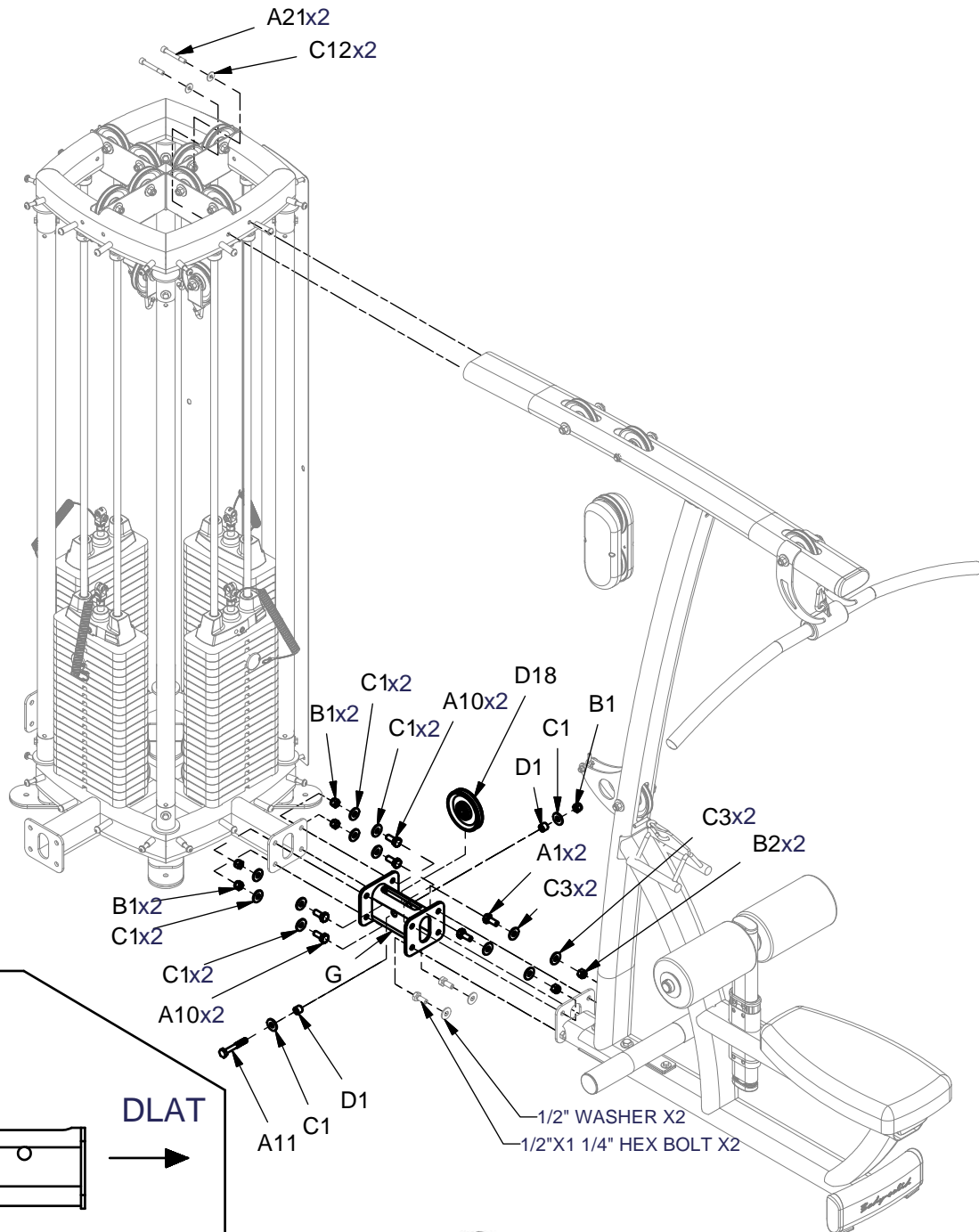

DLAT ASSEMBLY INSTRUCTIONS

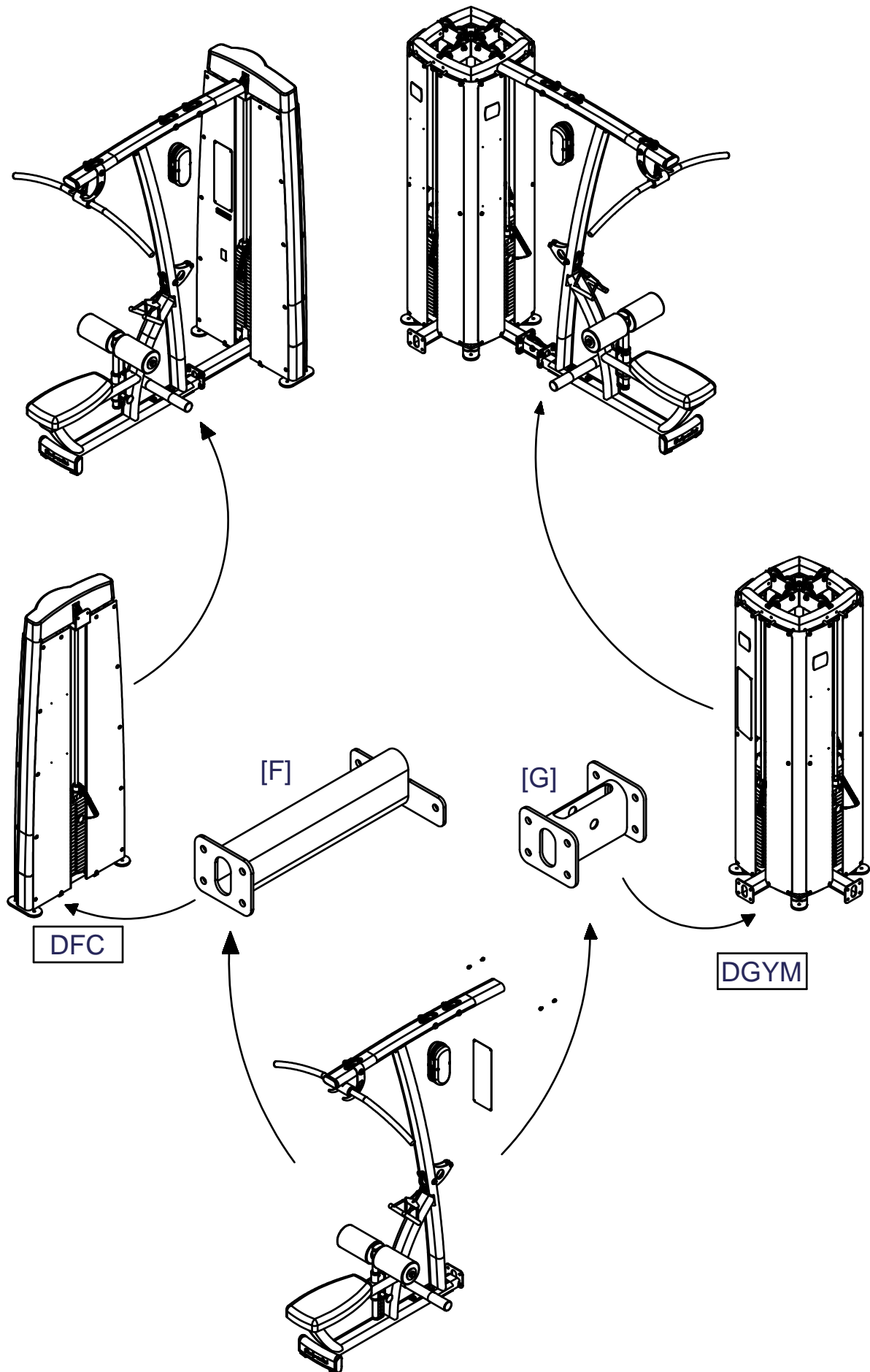

ASSEMBLY INSTRUCTIONS

Anti-cable Break Up Supplement Page

BA[2PCS]
8331-015

