

Body-Solid®

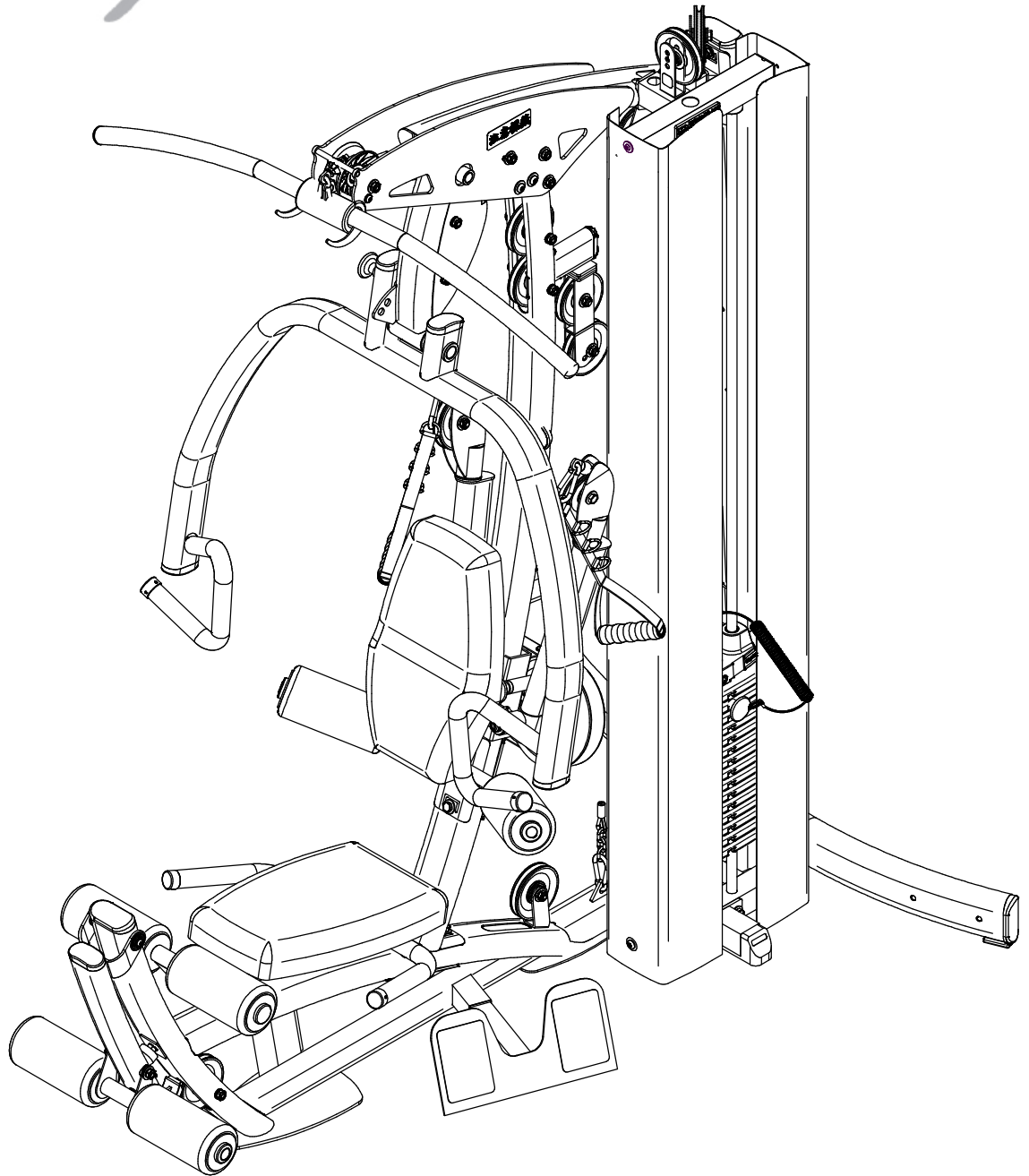

FUSION 500

PERSONAL TRAINER

Assembly

Instructions

OWNER'S & MANUAL

Warning, Safety & Maintenance

Be sure that all users carefully read and understand all warning, safety and maintenance labels on the machine before each use. Failure to do so may result in death or serious injury.

It is imperative that you retain your Owner's Manual and be sure all warning labels are legible and intact. Replacement Owner's Manuals and warning labels are available from your local Body-Solid dealer.

If you have any questions about the operation, set up or maintenance of this machine please call our customer service department at 1 (800) 556-3113.

THERE IS A RISK ASSUMED BY INDIVIDUALS WHO USE THIS TYPE OF EQUIPMENT. TO MINIMIZE RISK, YOU MUST FOLLOW THESE RULES:

1. Inspect equipment before each workout. Check that all nuts, bolts, screws and pop pins are in place and fully tightened. Also, before use, check cables for signs of wear. Replace all worn parts immediately. Never use machine if any parts are damaged or missing. **FAILURE TO FOLLOW THESE RULES MAY RESULT IN SERIOUS INJURY.**
2. Keep clear of the cables and all moving parts when the machine is in use.
3. Always make sure all Snap Links are closed when doing any cable/pulley/strap exercises.
4. Exercise with care. Perform your exercises at a smooth moderate pace; never perform jerky or uncoordinated movements that may cause injury.
5. It is recommended that you should workout with a training partner.
6. Do not allow children or minors to play on or around this equipment.
7. If unsure of proper use of equipment, call your local Body-Solid distributor or the Body-Solid customer service department at 1-800-556-3113.
8. **WARNING:** Consult your physician before starting your exercise program. For your own safety, do not begin any exercise program without proper instruction. RAL8-6-03 WC-54

WARNING

Safety and Maintenance of Cables

IMPORTANT: Cables are wear items. It is your responsibility to prevent unexpected breakage. **Cable inspection should be performed daily.** Inspect all cables, the nylon coating on all cables, and the area near the fitting at each end of each cable. **Replace any damaged or worn cable immediately.** Do not allow the machine to be used until damaged or worn cables are replaced. Using or allowing a machine to be used with a suspect cable can result in serious injury. See Owner's Manual for more information.

For Body-Solid Customer Service
Call 1-800-556-3113

MAINTENANCE SCHEDULE		D A I L Y	W E E K L Y
Check the function and integrity of the following components. As noted, inspect equipment before each workout. Replace all damaged, broken or worn components immediately.			
Cables:	Check tension, end fittings, and coating	✓	
	Check that locking nut at weight stack is tight		✓
Upholstery:	Wipe down and dry	✓	
	Clean and condition		✓
Frame:	Wipe down and dry	✓	
	Polish / Wax		✓
Chrome:	Wipe down and dry	✓	
	Polish / Lubricate		✓
Nuts / Bolts / Fasteners:	Tighten and / or adjust as needed		✓
Guide Rods:	Lubricate and clean		✓
Linear Rods:	Lubricate and clean		✓
Seat Sleeves:	Lubricate and clean		✓
Adjustments / Locking Pins / Tightening Knobs			✓
Weight Stack Pins			✓
Warning Instruction Labels			✓
Springs / Pop Pins		✓	
Anti Skid Surfaces			✓
Hand Grips / Rollers			✓

For Body-Solid Customer Service
Call 1-800-556-3113
#MSSTR0803

Total Body Workout DVD

Follow the lead of international fitness presenter Geoff Bagshaw as he guides you step by step through a total health and conditioning program. Includes thorough explanations and demonstrations of over 50 exercises targeting all major muscle groups. The Body-Solid Total Body Workout is a “must have” for anyone truly serious about in-home training.

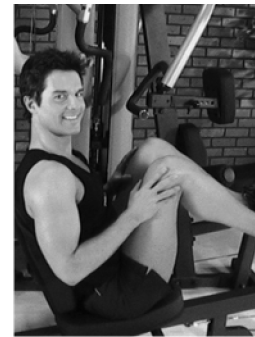

Also includes:

- Complete stretching routine
- Importance of cardio training
- Body-Solid company profile

Body-Solid

Total Body Workout DVD

Fusion 500

Reference Drawings

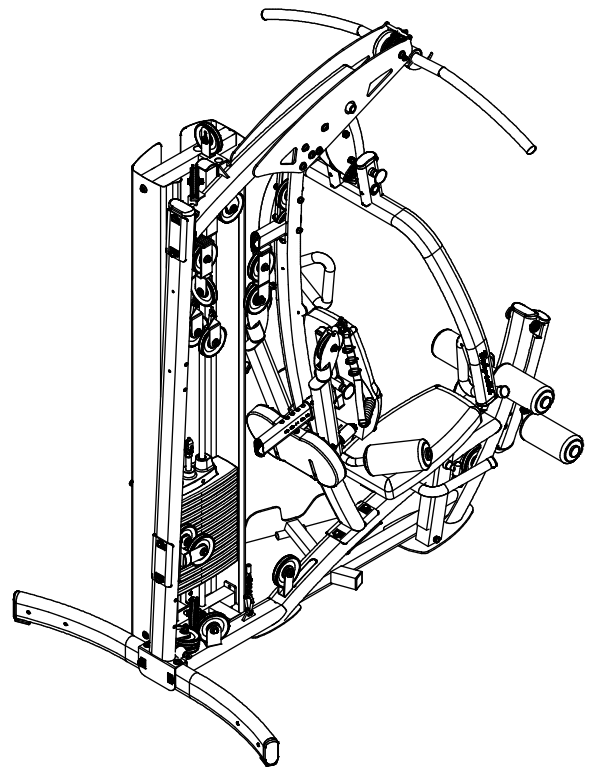
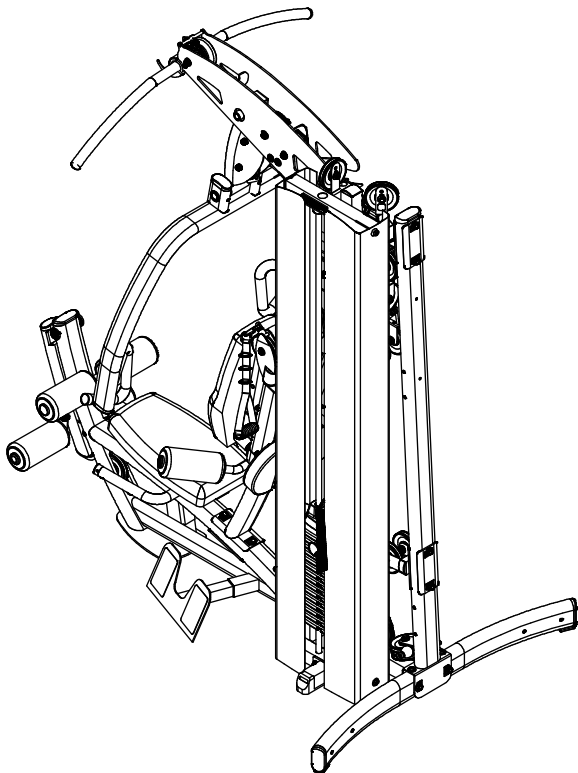
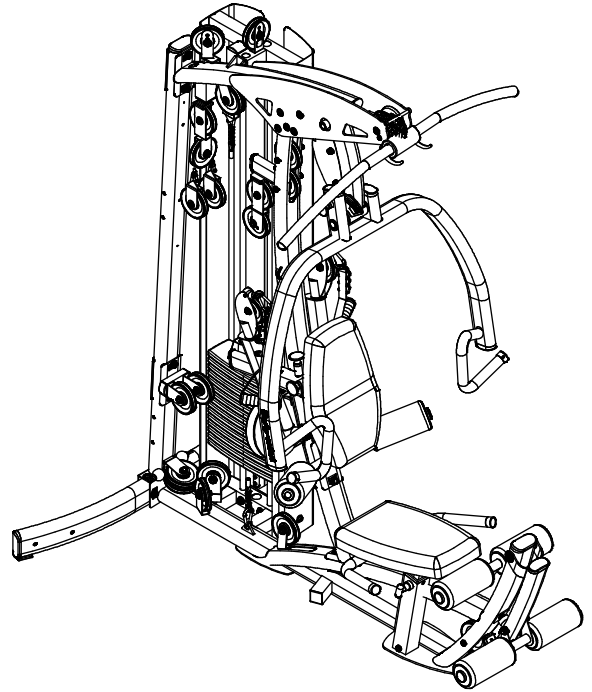
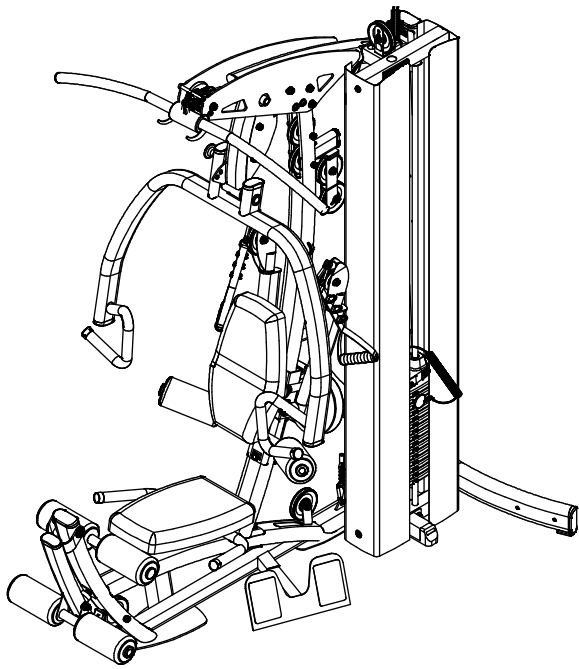

Note: Due to continuing product improvements, specifications and designs are subject to change without notice.
Even though we have prepared this manual with extreme care, neither the publisher nor the author can accept responsibility for any errors in, or omission from, the information given.

Important Safety Instructions

Before beginning any fitness program, you should obtain a complete physical examination from your physician.

*Il est conseillé de subir un examen médical complet avant d'entreprendre tout programme d'exercice.
Si vous avez des étourdissements ou des faiblesses, arrêtez les exercices immédiatement.*

Antes de comenzar cualquier programa de ejercicios, deberías tener un examen isico con su doctor.

When using exercise equipment, you should always take basic precautions, including the following:

- Read all instructions before using your machine. These instructions are written to ensure your safety and to protect the unit.
- **Do not remove any safety labels from the machine.**
- Do not allow children on or near the equipment.
- Use the equipment only for its intended purpose as described in this guide. Do not use accessory attachments that are not recommended by the manufacturer. Such attachments might cause injuries.
- Wear proper exercise clothing and shoes for your workout, no loose clothing.
- Keep hands, limbs, loose clothing, and long hair well out of the way of all moving parts.
- Use care when getting on or off the unit.
- Do not overexert yourself or work to exhaustion.
- If you feel any pain or abnormal symptoms, stop your workout immediately and consult your physician.
- Never operate unit when it has been dropped or damaged. Return the equipment to a service center for examination and repair.
- Never drop or insert objects into any opening in the equipment.
- **IMPORTANT:** Cables are wear items. It is your responsibility to prevent unexpected breakage. Cable inspection should be performed daily. Inspect all cables, and the area near the fitting at each end of each cable. Replace any damaged or worn cable immediately. Do not allow the machine to be used until these are replaced.

- Do not use the equipment outdoors or near water.

Personal Safety During Assembly

- Before beginning assembly, please take the time to read the instructions thoroughly.
- Read each step in the assembly instructions and follow the steps in sequence. Do not skip ahead. If you skip ahead, you may learn later that you have to disassemble components and that you may have damaged the equipment.
- Assemble and operate your machine on a solid, level surface. Locate the unit a few feet from the walls or furniture to provide easy access.

Your machine is designed for your enjoyment. By following these precautions and using common sense, you will have many safe and pleasurable hours of healthful exercise.

After assembly, you should check all functions to ensure correct operation. If you experience problems, first recheck the assembly instructions to locate any possible errors made during assembly. If you are unable to correct the problem, call the dealer from whom you purchased the machine or call **1-800-556-3113** for the dealer nearest you.

Obtaining Service

Please use your Owner's Manual to make sure that all parts have been included in your shipment. When ordering parts, you must use the part number and description from your Owner's Manual. Use only Body-Solid replacement parts when servicing this machine. Failure to do so will void your warranty and could result in personal injury.

For information about product operation or service, check out the official Body-Solid website at www.bodysolid.com or contact an authorized Body-Solid dealer or a Body-Solid factory-authorized service company or contact Body-Solid customer service at one of the following:

Toll Free: 1-800-556-3113
Phone: 1-708-427-3555
Fax: 1-708-427-3556
Hours: M-F 8:30-5:00 CST
E-Mail: service@bodysolid.com

**Or write to: Body-Solid, Inc.
Service Department
1900 S. Des Plaines Ave.
Forest Park, IL 60130 USA**

Retain this Owner's Manual for future reference. If you need to order replacement parts please be prepared to provide the following information when contacting us so that we can assist you better.

- 1. Model Number**
- 2. Proof of Purchase**
- 3. Place of Purchase**
- 4. Serial Number (S/N)**
- 5. Part # and Description**

Dimensions

The room layout diagram below will help you decide the best placement for your Fusion 500.

The dimensions of the Fusion 500 are: width 3' 11" X length 6' 4".

The ceiling height requirement for the Fusion 500 is 6' 18".

The usage space is: width 6' X length 10' (The usage space is the overall space needed for operation.)

The usage space needed for the Fusion 500 could be more, depending if the user allows enough room for the Low Row Station.

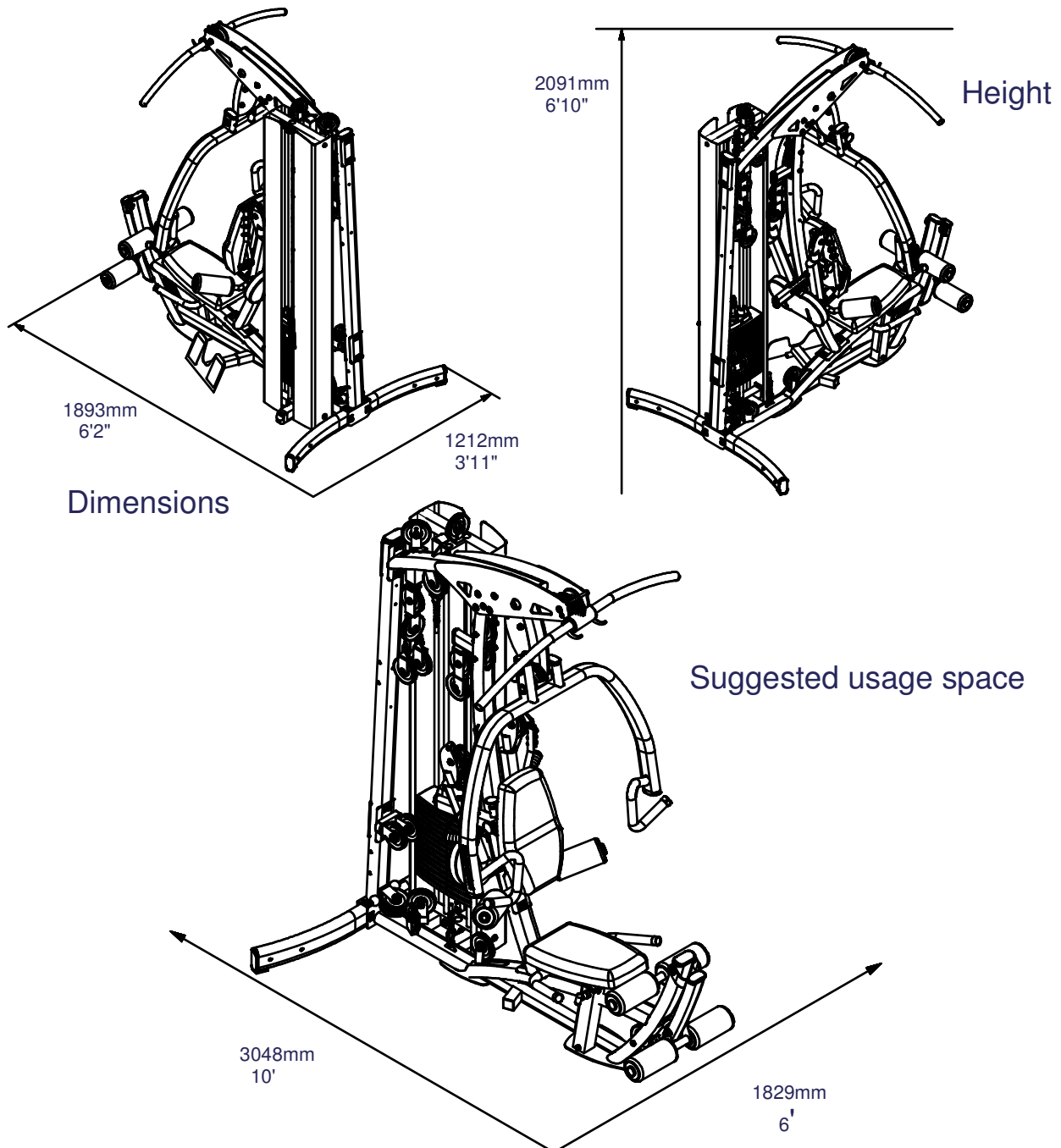

Safety Guidelines

Successful resistance training programs have one prominent feature in common...safety. Resistance training has some inherent dangers, as do all physical activities. The chance of injury can be greatly reduced or completely removed by using correct lifting techniques, proper breathing, maintaining equipment in good working condition, and by wearing the appropriate clothing.

- 1. It is highly recommended that you consult your physician before beginning any exercise program. This is especially important for individuals over the age of 35, or persons with pre-existing health problems.**
- 2. Always warm up before starting a workout. Try to do a total body warm up before you start. It is especially important to warm up the specific muscle groups you are going to be using. This can be as simple as performing a warm up set of high repetitions and light weight for each exercise.**
- 3. Use proper form. Focus on only working the muscle groups intended for the exercise you are doing. If there is strain elsewhere, you may need to re-evaluate the amount of weight that is involved with the lift. Keeping proper form also includes maintaining control through an entire range of motion.**
- 4. Breath properly. Inhale during the eccentric phase of the exercise, and exhale during the lifting, or concentric phase. Never hold your breath during any part of an exercise.**
- 5. Always wear the appropriate clothing and shoes when exercising. Wearing comfortable athletic shoes with good support and loose fitting, breathable clothing will reduce the risk of injury.**
- 6. Maintaining equipment in proper operating condition is of utmost importance for a safe resistance training program. Pulleys and cables should be checked for wear frequently and replaced as needed. Equipment should be lubricated as indicated by the manufacturer.**
- 7. Read and study all warning labels on this machine. It is absolutely necessary that you familiarize yourself and all others with the proper operation of this machine prior to use.**
- 8. Keep hands, limbs, loose clothing and long hair well out of the way of all moving parts.**
- 9. Do not attempt to lift more weight than you can control safely.**
- 10. Inspect the machine daily for loose or worn parts. If a problem is found do not allow the machine to be used until all parts are tightened or worn or defective parts are repaired or replaced.**

Assembly Instructions

Assembly of the Fusion 500 takes professional installers about 3 hours to complete. If this is the first time you have assembled this type of equipment, plan on significantly more time.

PROFESSIONAL INSTALLERS ARE HIGHLY RECOMMENDED!

However, if you acquire the appropriate tools, obtain assistance, and follow the assembly steps sequentially, the process will take time, but is fairly easy.

Assembly Tips

Read all "Notes" on each page before beginning each step.

While you may be able to assemble the Fusion 500 using the illustrations only, important safety notes and other tips are included in the text.

Some pieces may have extra holes that you will not use. Use only those holes indicated in the instructions and illustrations.

NOTE: To find out the length of a particular bolt, measure its shank (the long, narrow part beneath the head). Refer to the following diagram:

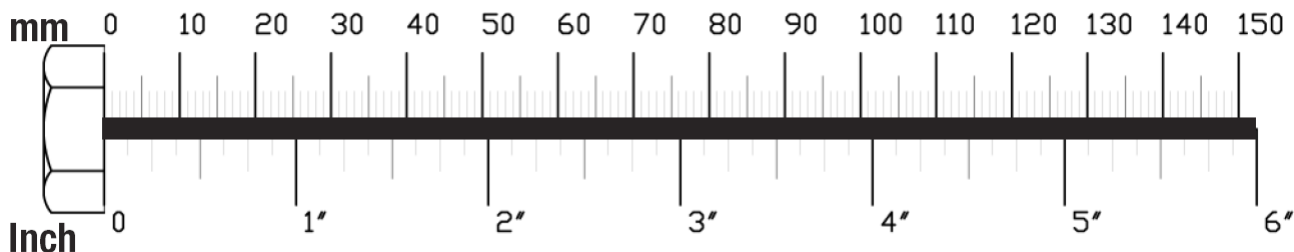
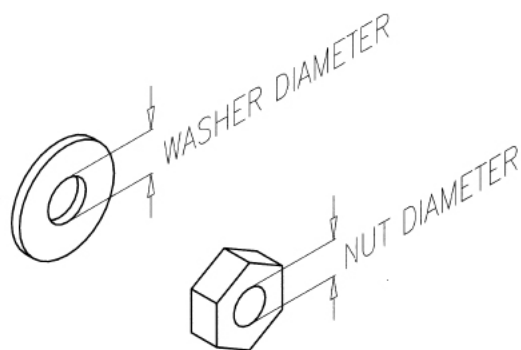
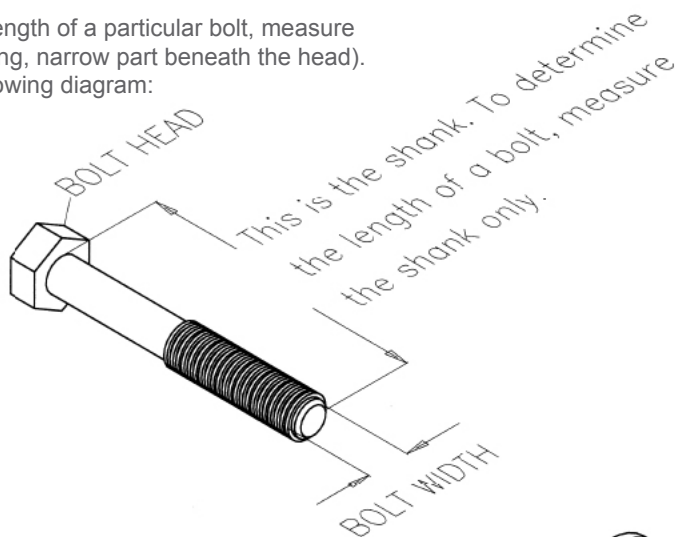

Do not fully tighten bolts until instructed to do so.

Note: After assembly, you should check all functions to ensure correct operation. If you experience problems, first recheck the assembly instructions to locate any possible errors made during assembly. If you are unable to correct the problem, call the dealer from whom you purchased the machine or call 1-800-556-3113 for the dealer nearest you.

STEP

1

Be careful to assemble all components in the sequence they are presented.

NOTE:

Finger tighten all hardware in this step. **Do Not** wrench tighten until end of step 15. Some components may be pre-assembled.

- A. Insert Weight Stack Shim (9) under Main Base Frame (A).
- B. Assemble Rear Leg (E) in between Main Base Frame (A) and Rear Upright Frame(B) by using:
Two 50 (M10x75 partial thread hex head bolt)
Four 101 (M10 washer)
Two 60 (M10 nylon lock nut)
- C. Reinforce Rear Upright Frame (B) by using:
Two 5 (M10x15 full thread allen head bolt)
Two 101 (M10 washer)
- D. Connect Assistant Support (AJ) to Main Base Frame (A) by using:
Two 49 (M10x70 partial thread hex head bolt)
Four 101 (M10 washer)
Two 60 (M10 nylon lock nut)
- E. Insert Cable End Shaft (23) into Assistant Support (AJ).
Insert Foot Cap (42) to the ends of Rear Leg (E).
Insert Flat End Cap (35) into Main Base Frame (A) as shown in the diagram.
Insert Convex End Cap (29) into Rear Upright Frame (B).

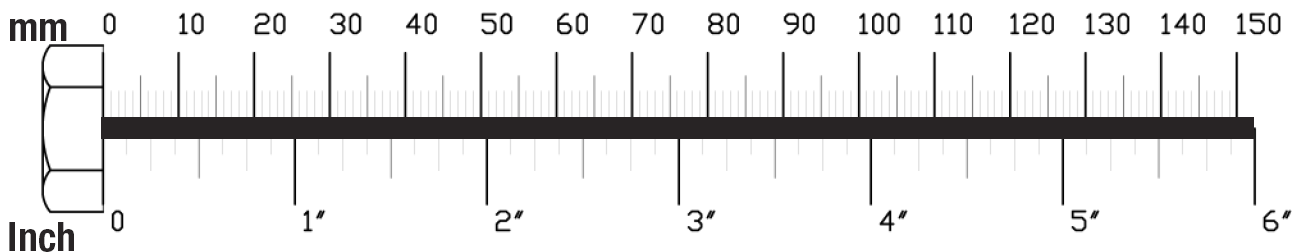

STEP
1

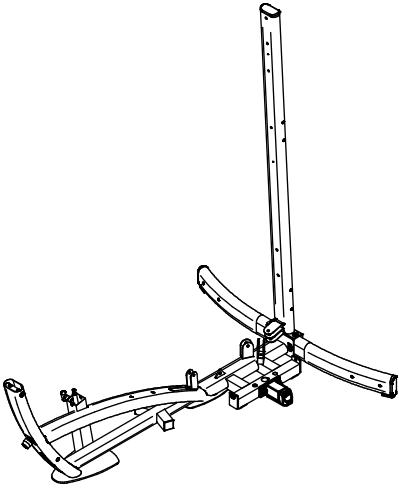

Above shows STEP 1
assembled and completed

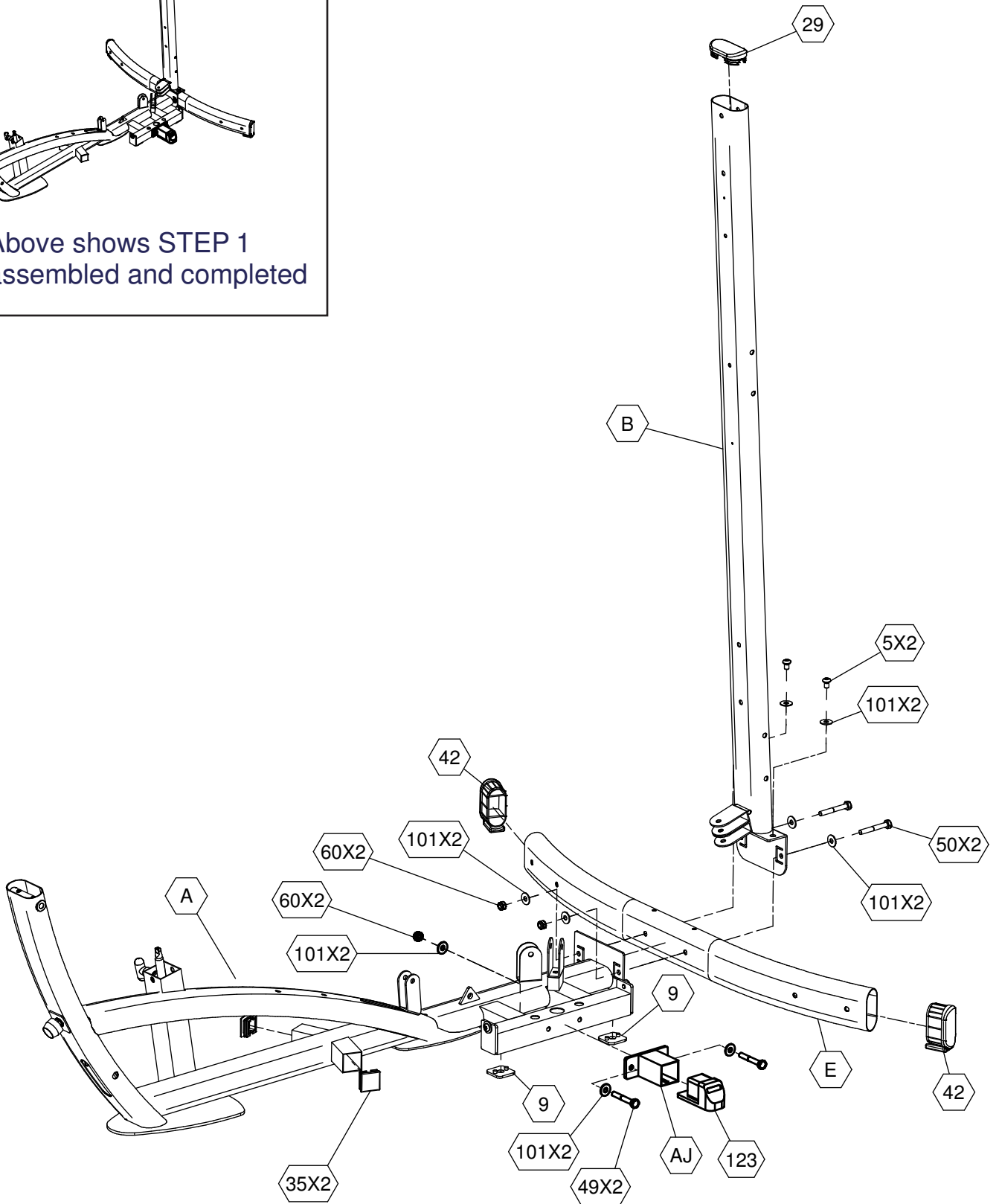

STEP**2****Be careful to assemble all components in the sequence they are presented.****NOTE:**

Finger tighten all hardware in this step. Do Not wrench tighten until end of Step 15. Some components may be pre-assembled.

- A. Connect Main Front Frame (N) and Rear Leg (H) to Main Base Frame (A) by using:
Two 49 (M10x70 partial thread hex head bolt)
Four 101 (M10 washer)
Two 60 (M10 nylon lock nut)
- B. Attach Main Top Frame (C) onto Main Front Frame (N) using:
Two 3 (M10x125 partial thread allen head bolt)
Four 101 (M10 washer)
Two 60 (M10 nylon lock nut)
- C. Insert Convex End Cap (27) to Main Front Frame (N).
- D. Connect Main Top Frame (C) and Rear Leg (H) to Rear Upright Frame (B) using:
Two 50 (M10x75 partial thread hex head bolt)
Four 101 (M10 washer)
Two 60 (M10 nylon lock nut)
- E. Position Rubber Donut (75) onto holes as shown in the diagram.
- F. Slide Shaft Collar (81) onto Chrome Guide Rod (G) one at a time.
Make sure the Allen Screw (16) inside the Shaft Collar (81) are loose.
- G. Insert Selector Rod (78) through Top Plate (95) and secure using:
One 87 (3/8"x2" partial thread socket head bolt)
One 91 (3/8" spring lock washer)
- H. Slide Top Plate (95) Assembly down Chrome Guide Rod (G).
- I. Apply Allen Screw (16) to the top of Chrome Guide Rod (G) and secure to Main Top Frame (C) by sliding Allen Screw (16) into Main Top Frame (C) and tightening Allen Screw (16).
- J. Connect Weight Stack Pin (8) to Weight Stack Pin Lanyard (7) then insert into any one of the Weight Stack Plates (6).

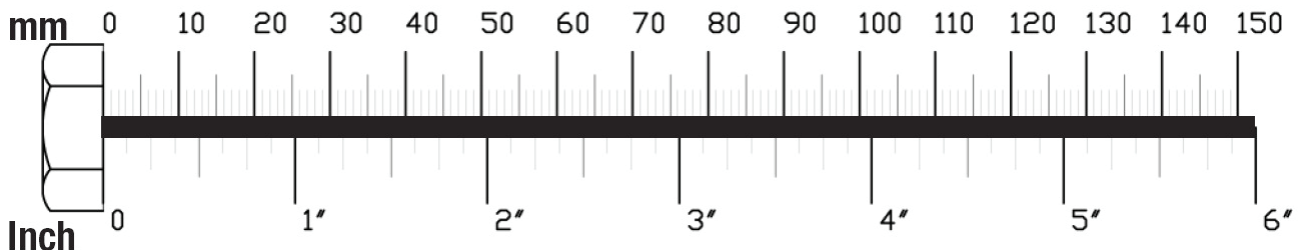

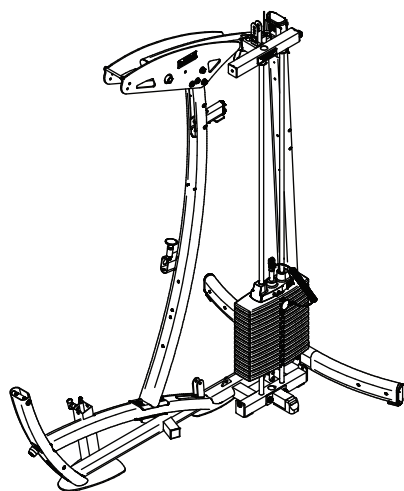

Above shows STEP 2 assembled and completed

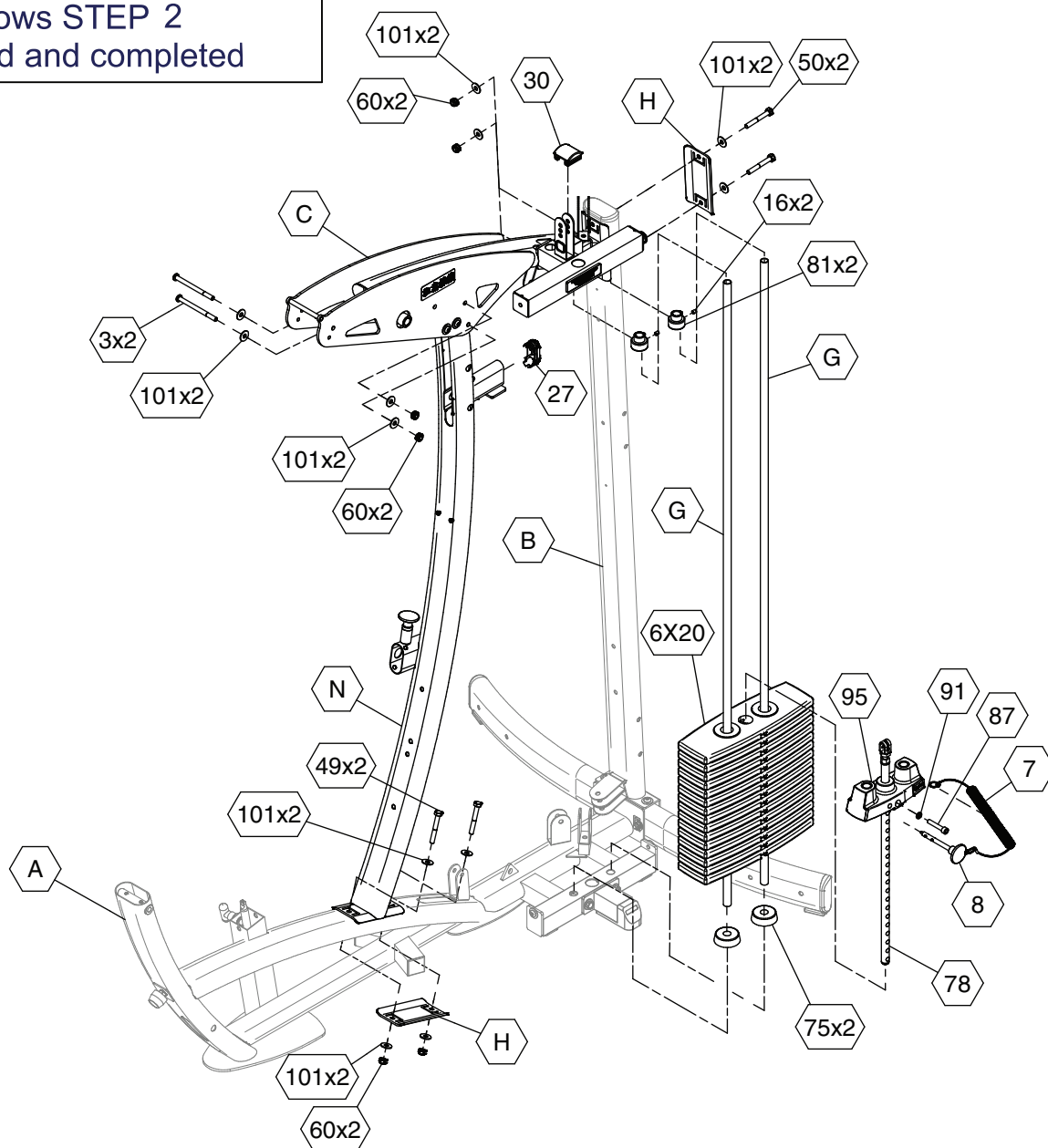

STEP**3****Be careful to assemble all components in the sequence they are presented.****NOTE:**

Finger tighten all hardware in this step. Do Not wrench tighten until end of step 15. Some components may be pre-assembled.

- A. Connect Left Functional Training Arm (W) and Right Functional Training Arm (X) to Functional Training Arms Pivot Base (T) by using:
Four 61 (bearing)
One 97 (left torsional spring)
One 98 (right torsional spring)
Two 102 (M12 washer)
Two 60 (M10 nylon lock nut)
- B. Connect Functional Training Arms Pivot Base (T) to Main Front Frame (N) by using:
Two 50 (M10x75 partial thread hex head bolt)
Four 101 (M10 washer)
Two 60 (M10 nylon lock nut)
- C. Attach Nameplate Seat (66) to Main Front Frame (N) by using:
Two 25 (M5x10 tapered crosshead screw)
Apply Nameplate (65) to Nameplate Seat (66).
- D. Connect Functional Training Arms Rear Pulley Support (AA) and Contoured Backing Plate (H) to Rear Upright Frame (B) using:
Two 50 (M10x75 partial thread hex head bolt)
Four 101 (M10 washer)
Two 60 (M10 nylon lock nut)
- E. Insert Convex End Cap (26) to both ends of Functional Training Arms Rear Pulley Support (AA).

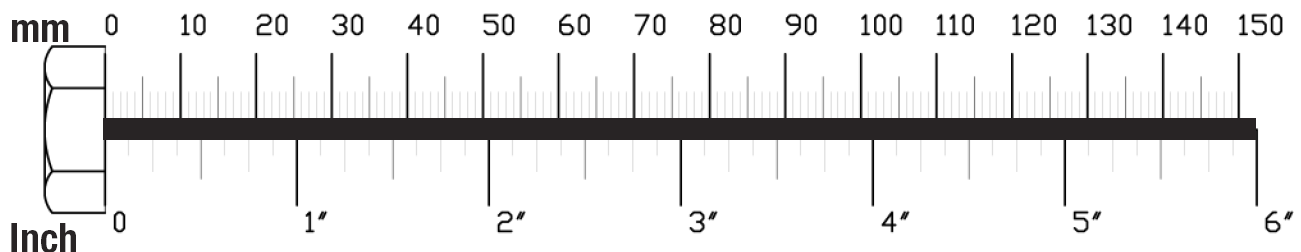

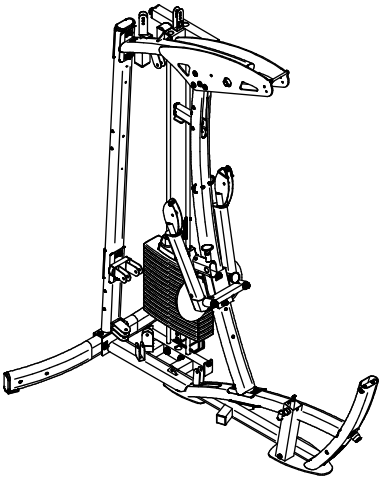

Above shows STEP 3 assembled and completed

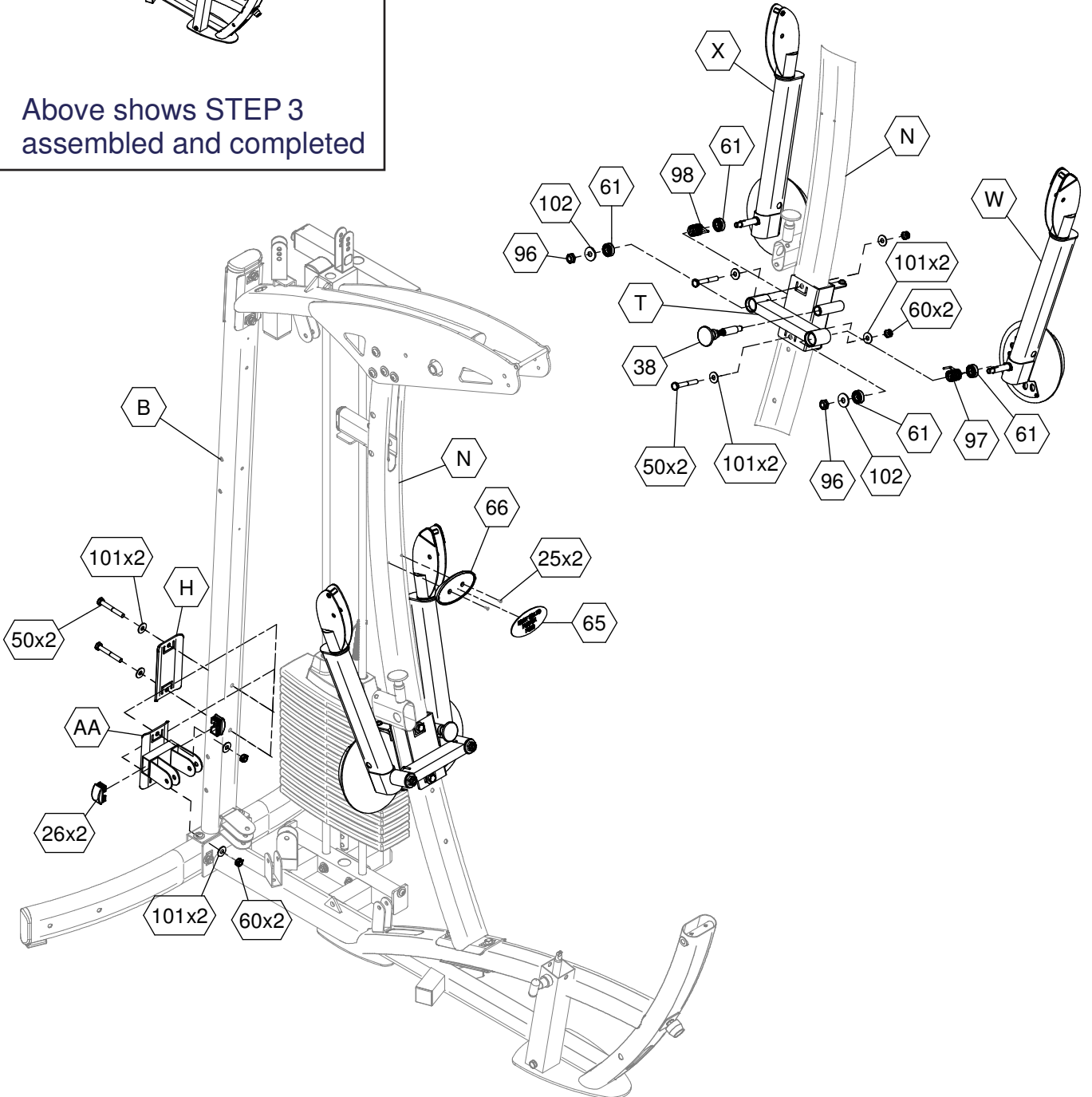

STEP**4****Be careful to assemble all components in the sequence they are presented.****NOTE:**

Finger tighten all hardware in this step. Do Not wrench tighten until end of step 15. Some components may be pre-assembled.

- A. Insert Bushing (63) and Bearing (21) to Press Arm Support (K) as shown in the Detail View of Step 4.
- B. Insert Convex End Cap (28) and Pop Pin (36) to Seated Press Arm (F).
- C. Slide Shaft (80) into Seated Press Arm (F) and Press Arm Support (K) and tighten Allen Screw (15) as shown in the diagram.
- D. Install Pulley (71) to Main Top Frame (C) by using:
Two 89 (spacer sleeve)
One 3 (M10x125 partial thread allen head bolt)
Two 101 (M10 washer)
One 60 (M10 nylon lock nut)
- E. Install Press Arm Stop (AD) to Main Front Frame (N) by using:
Four 5 (M10x15 allen head bolt)
Four 101 (M10 washer)
Attach Rubber Stop (77) and Jam Nut (56) to Press Arm Stop (AD).
- F. Take assembly Press Arm Support (K) and Seated Press Arm (F) and connect to Main Top Frame (C) using Shaft (83). Tighten Allen Screw (15).

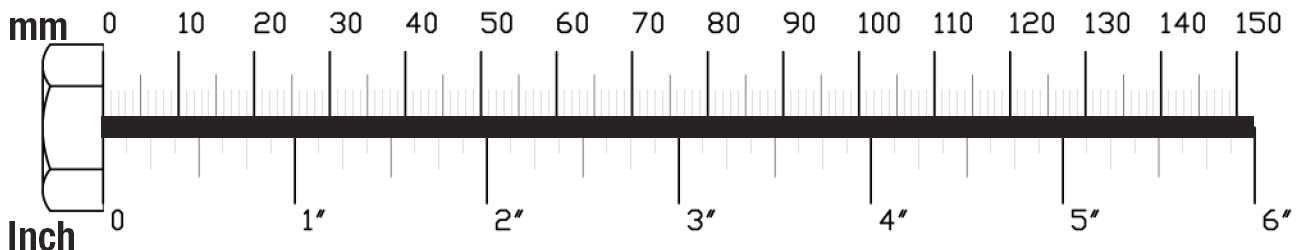

STEP
4

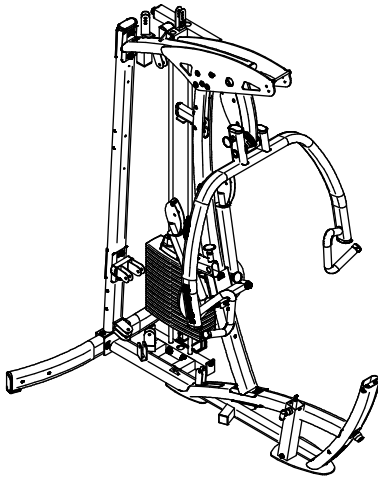

Above shows STEP4
assembled and completed

DETAIL VIEW

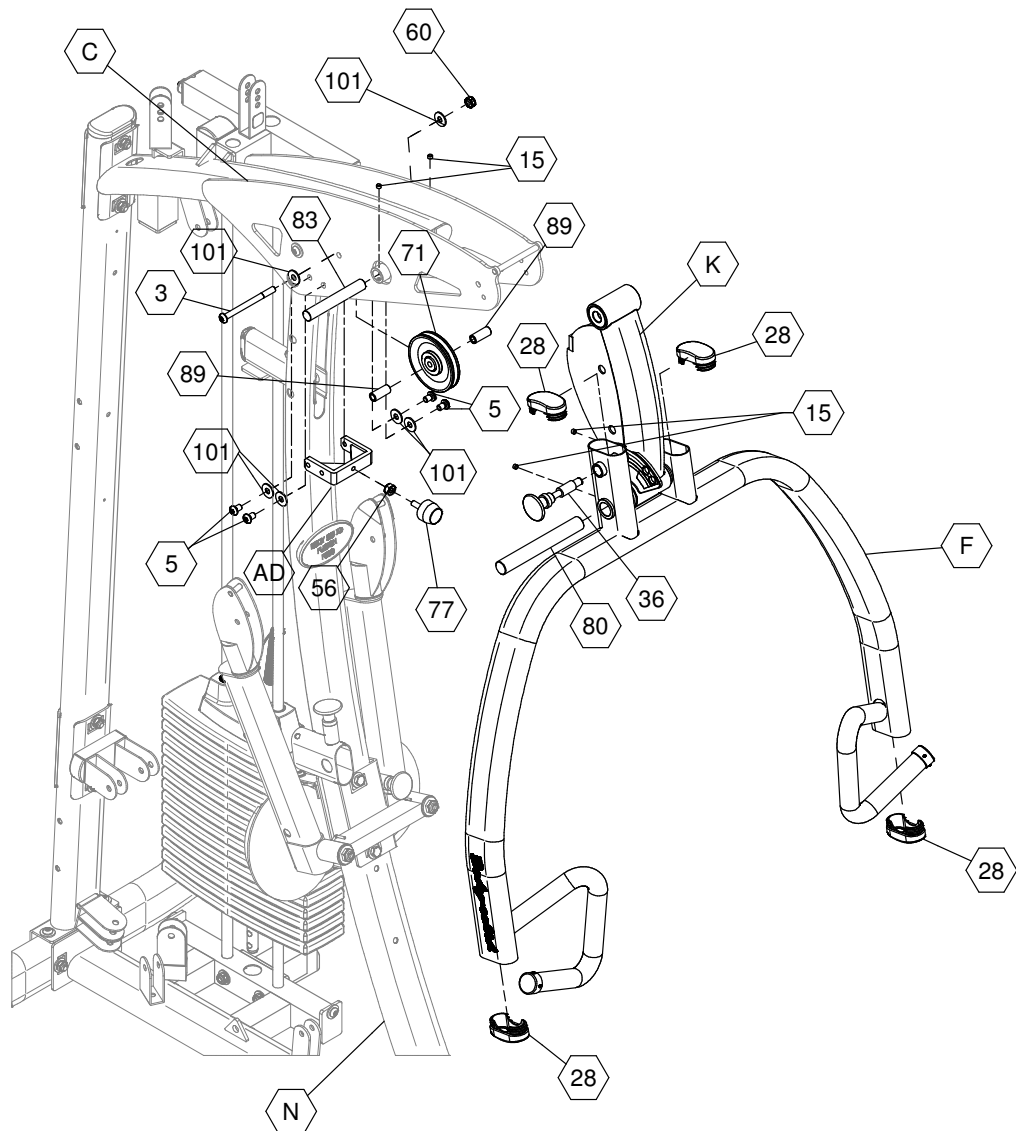
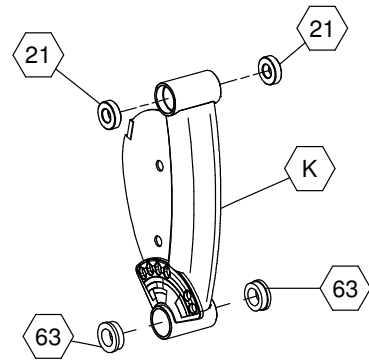

STEP**5****Be careful to assemble all components in the sequence they are presented.****NOTE:**

Finger tighten all hardware in this step. Do Not wrench tighten until end of step 15. Some components may be pre-assembled.

- A. Connect Leg Hold Down Frame (S) and Contoured Backing Plate (H) to Main Front Frame (N) using:
Two 50 (M10x75 partial thread hex head bolt)
Four 101 (M10 washer)
Two 60 (M10 nylon lock nut)
- B. Slide Nylon Washers (62), Foam Roller (41) and Roller End Cap (73) to both sides of Leg Hold Down Frame (S).
- C. Slide Nylon Bushing (58) into Main Front Frame (N).
- D. Attach Pivoting Back Rest Frame (L) to Back Pad Adjuster (O) by using:
One 5 (M10x15 allen head bolt)
One 100 (M10 washer)
Two 64 (bushing)
- E. Connect Back Pad (BB) to Pivoting Back Rest Frame (L) by using:
Two 52 (M8x50 partial thread hex head bolt)
Two 92 (M8 spring lock washer)
Two 103 (M8 washer)
- F. Insert Convex End Cap (26) into Pivoting Back Rest Frame (L).
Insert Back Pad Angle Adjuster Pop Pin (37) onto Back Pad Adjuster (O).
Insert Convex End Cap (27) onto Back Pad Adjuster (O).
- G. Slide Back Pad Assembly into Main Front Frame (N) as shown in the diagram.
- H. Insert Socket Head Bolt (88) into Back Pad Adjuster (O).

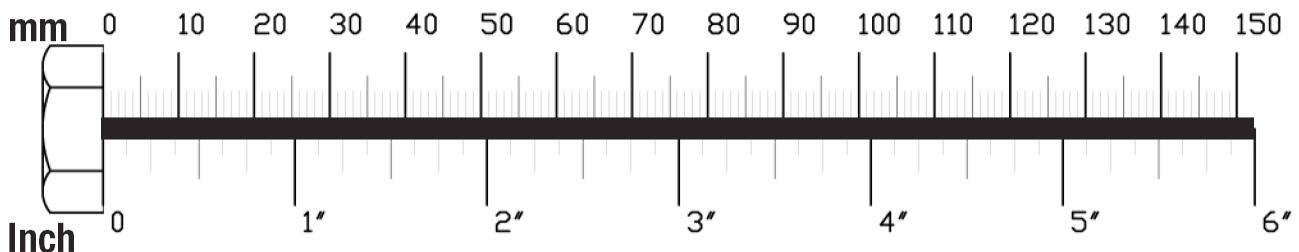

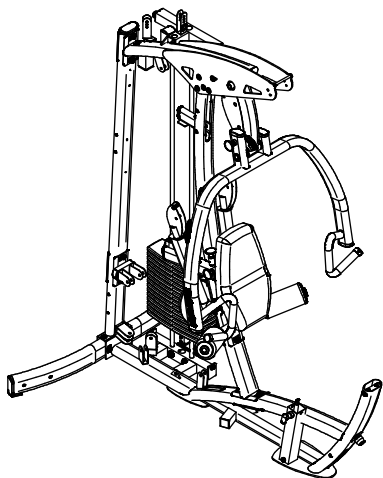

Above shows STEP 5 assembled and completed

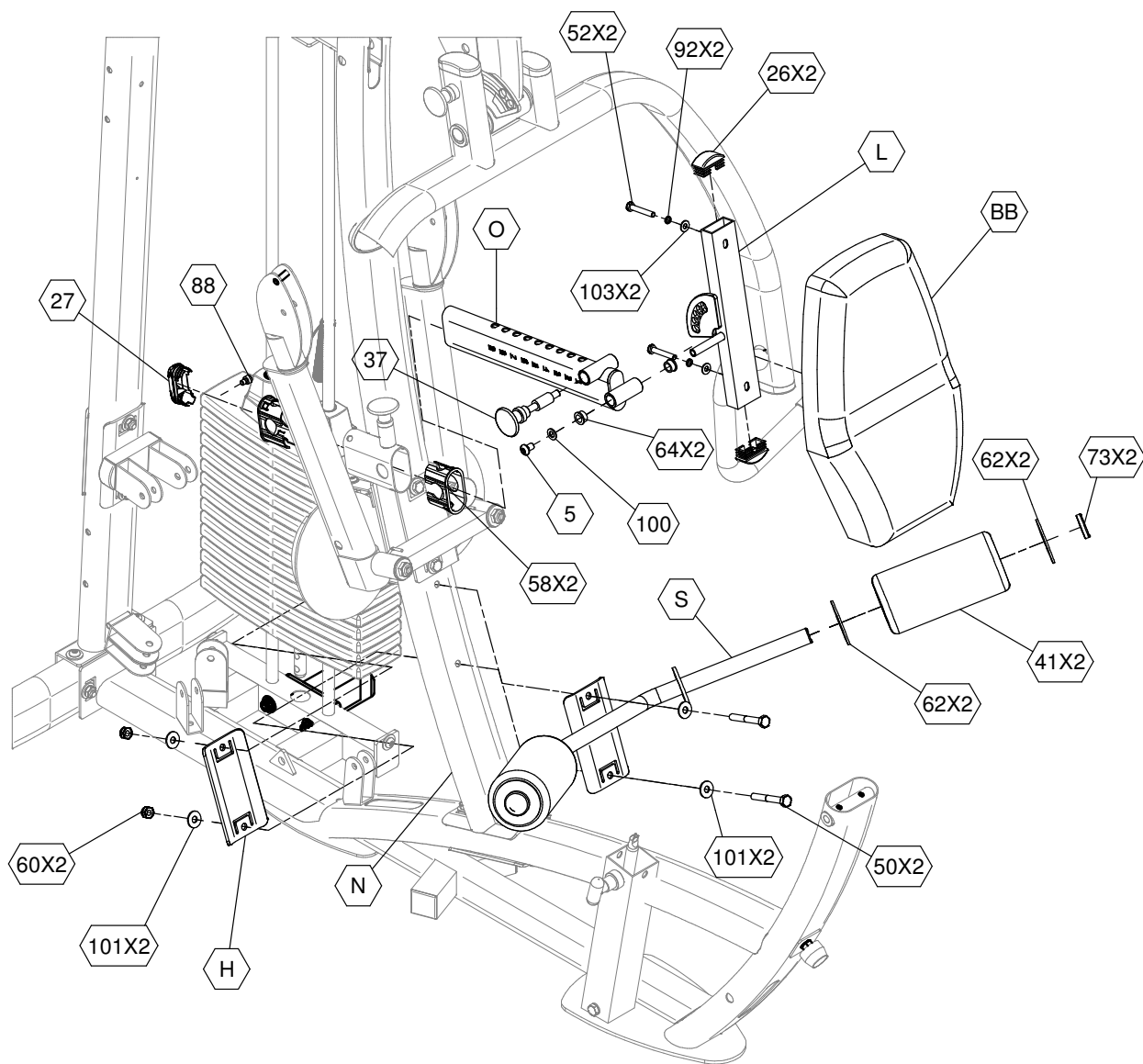

STEP**6****Be careful to assemble all components in the sequence they are presented.****NOTE:**

Finger tighten all hardware in this step. Do Not wrench tighten until end of step 15. Some components may be pre-assembled.

- A. Slide Nylon Bushing (59) into Adjustable Seat Frame (Q).
Connect Hydraulic Seat Adjuster (54) to Main Base Frame (A) by using:
One 51 (M10x65 partial thread hex head bolt)
One 100 (M10 washer)
- B. Insert T-Shaped Pop Pin (99) and Hydraulic Seat Adjuster (54) into Main Base Frame (A) as shown in the diagram.
- C. Slide Adjustable Seat Frame (Q) into Main Base Frame (A) and attach Hydraulic Seat Adjuster (54) to Adjustable Seat Frame (Q) by using:
One 46 M10x60 (partial thread hex head bolt)
Two 100 (M10 washer)
One 60 (M10 nylon lock nut)
Two 130 (Steel casing)
- D. Attach Left Arm Rest (AG) and Right Arm Rest (AH) to Adjustable Seat Frame (Q) using:
Two 45 (M10x85 partial thread hex head bolt)
Four 101 (M10 washer)
Two 60 (M10 nylon lock nut)
- E. Insert Flat End Cap (32) into ends of Adjustable Seat Frame (Q).
- F. Connect Seat Pad (BA) to Adjustable Seat Frame (Q) using:
Two 53 (M8x55 partial thread hex head bolt)
Two 92 (M8 spring lock washer)
Two 103 (M8 washer)
- G. Slide Roller Bar (J) through Adjustable Seat Frame (Q) and attach Foam Roller (41), Nylon Washer(62), Roller End Cap (73).

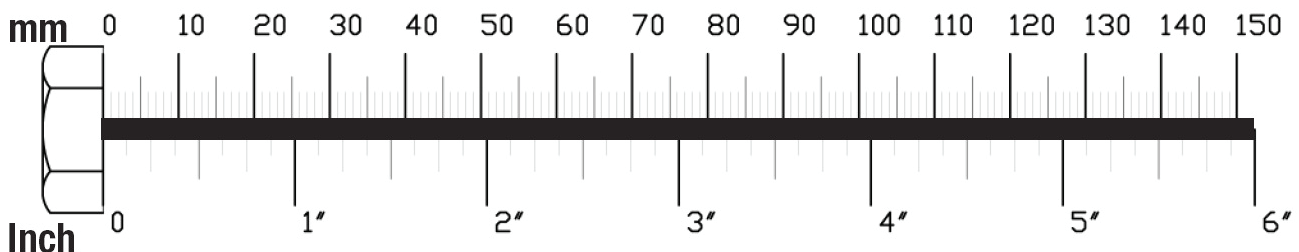

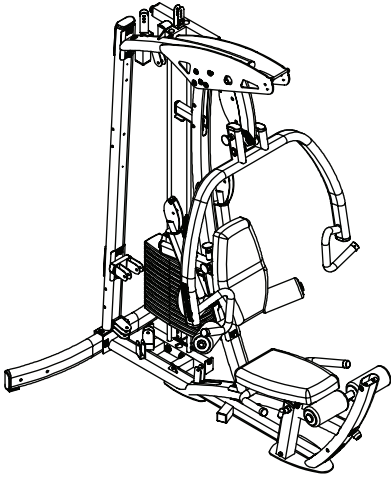

Above shows STEP 6 assembled and completed

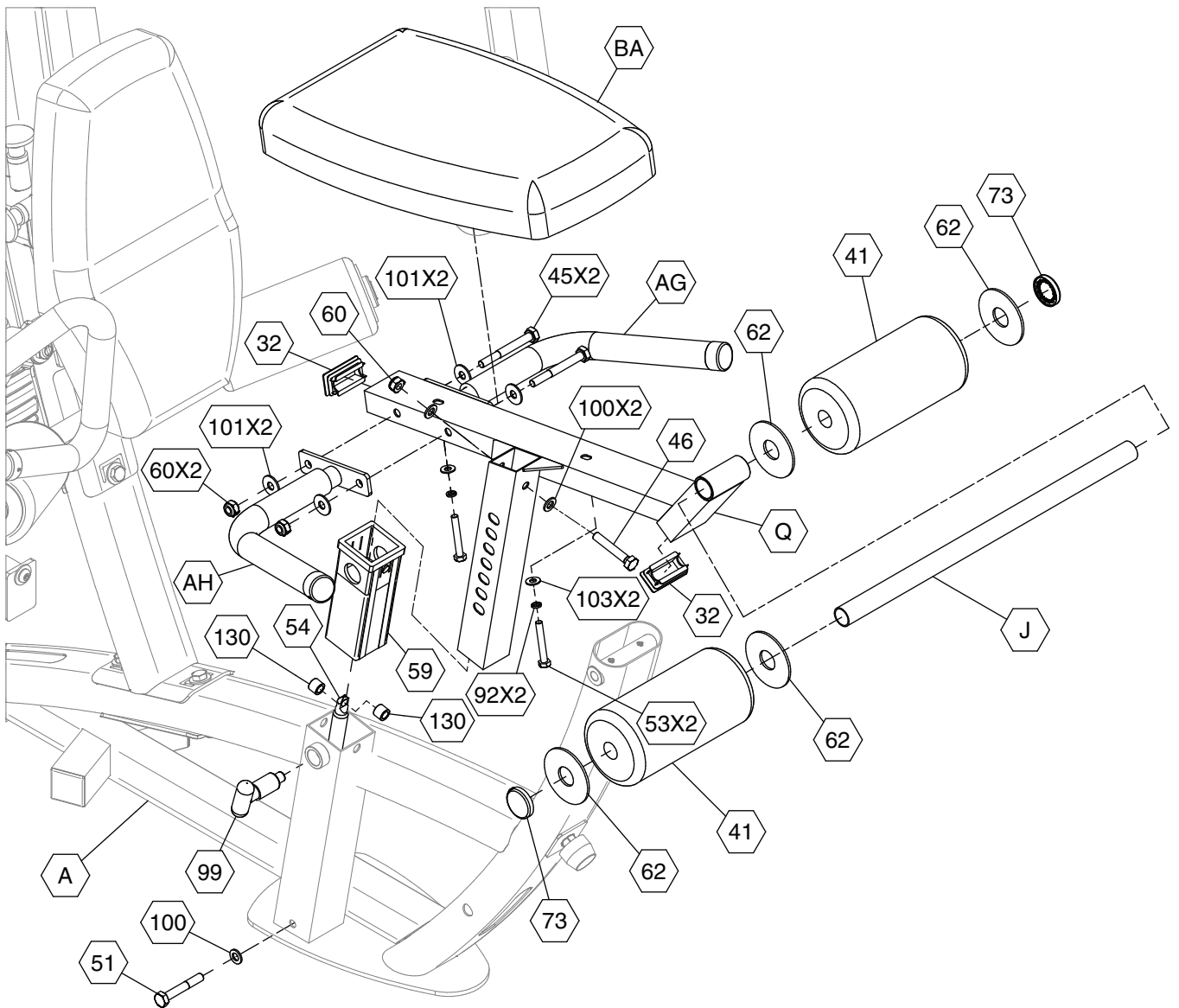

STEP**7****Be careful to assemble all components in the sequence they are presented.****NOTE:**

Finger tighten all hardware in this step. Do Not wrench tighten until end of step 15. Some components may be pre-assembled.

- A. Connect Pulley (70) to Main Top Frame (C) by using:
One 3 (M10x125 partial thread allen head bolt)
Two 101 (M10 washer)
One 60 (M10 nylon lock nut)

- B. Connect Left Lat Pull Down Bar Holder (AE) and Right Lat Pull Down Bar Holder(AF) to Main Top Frame (C) by using:
Two 10 (M8x10 allen head bolt)
Two 103 (M8 washer)

- C. Attach (124) to Bushing (AI) as shown in the diagram.

- D. Connect Functional Training Arms Rear Pulley (Z) to Main Base Frame (A) by using:
One 82 (Shaft)
Two 20 (Bearing)
Two 103 (M10 washer)
Two 11 (M8x15 allen head bolt)
Insert Convex End Cap (28) to Functional Training Arms Rear Pulley (Z) and Convex End Cap (29) by using:
One 44 (M10x110 partial thread hex head bolt)
Two 101 (M10 washer)
One 60 (M10 nylon lock nut)

- F. Slide Roller Bar (I) into Bushing (AI) along with Foam Roller (41), Nylon Washer (62), and Roller End Cap (73).
One 124 (Rubber Pad)

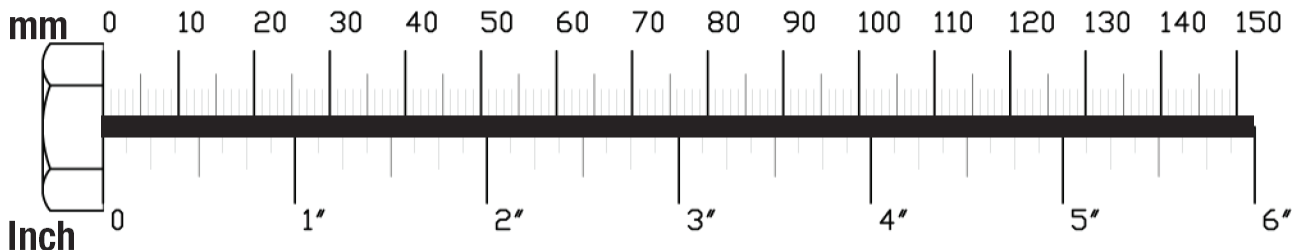

STEP
7

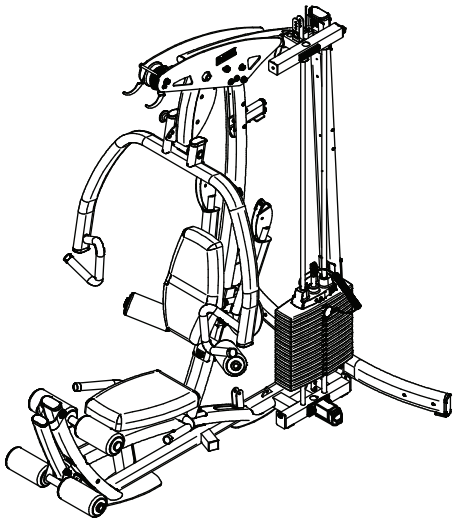

Above shows STEP 7 assembled and completed

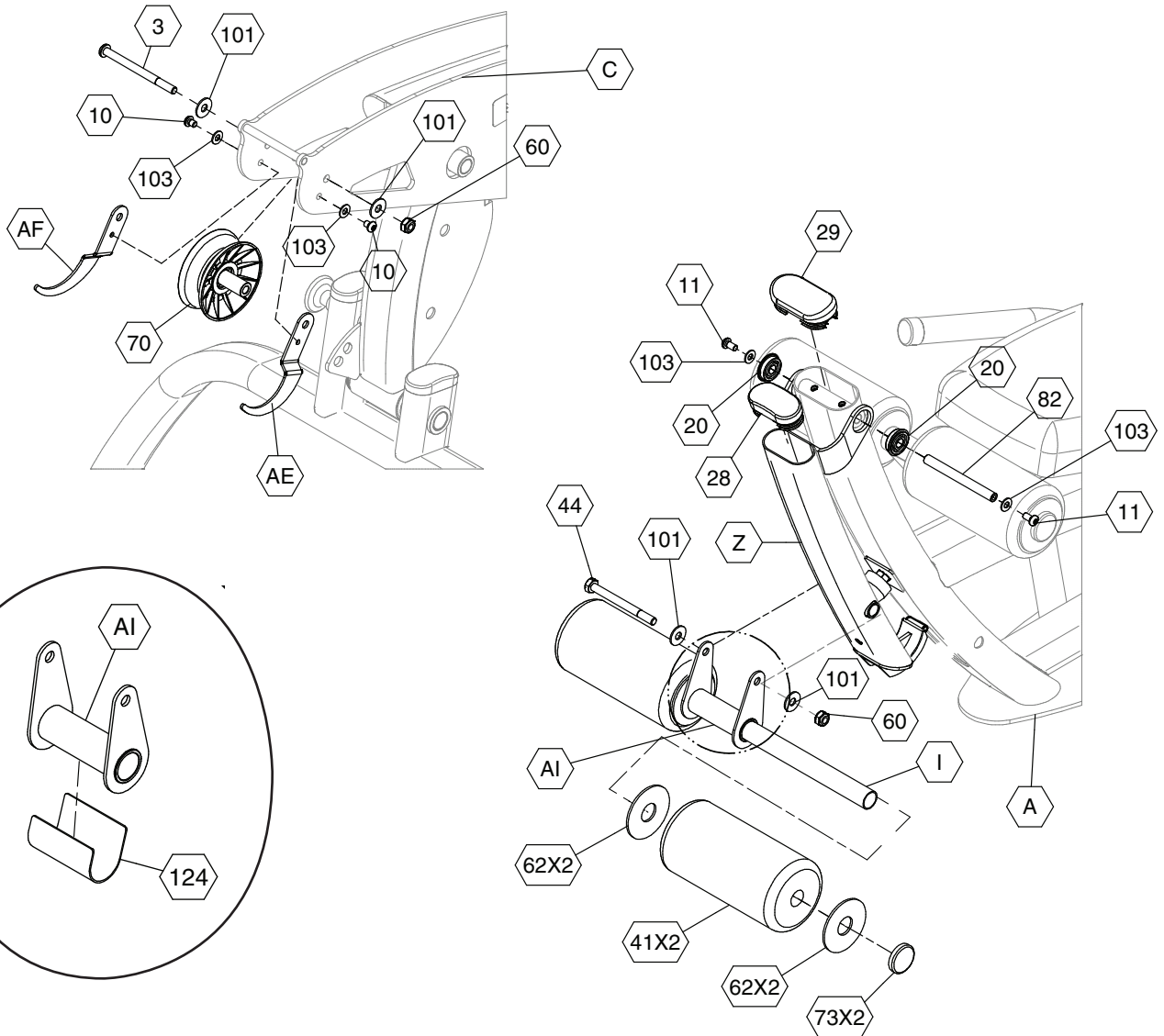

STEP**8****Be careful to assemble all components
in the sequence they are presented.****NOTE:**

**Finger tighten all hardware in this step. Do Not wrench tighten until end of step 15.
Some components may be pre-assembled.**

- A. Connect Pulley (71) to Holder for Double Parallel Pulleys (P) as shown in Diagram A using:
One 47 (M10x45 partial thread hex head bolt)
Two 101 (M10 washer)
One 60 (M10 nylon lock nut)
Attach Rubber Pad (76) to Holder for Double Parallel Pulleys (P).
- B. Connect Pulley (71) to Holder for Double Crossed Pulleys (U) as shown in Diagram B using:
One 47 (M10x45 partial thread hex head bolt)
Two 101 (M10 washer)
One 60 (M10 nylon lock nut)
Attach Rubber Pad (76) to Holder for Double Crossed Pulleys (U).
- C. Connect Pulley (71) to Pulley Holder with Stop (D) as shown in Diagram C using:
One 47 (M10x45 partial thread hex head bolt)
Two 101 (M10 washer)
One 60 (M10 nylon lock nut)
Attach Rubber Pad (76) to Pulley Holder with Stop (D).
- D. Connect Snap Link (86) to Lat Bar (114) and install after routing cable in Step 9.
- E. Connect Pulley (71-G) and Pulley (71-F) to Press Arm Support (K) using:
Two 50 (M10x75 partial thread hex head bolt)
Four 68 (pulley spacer)
Two 60 (M10 nylon lock nut)
- F. Connect Pulley (71-D) and Pulley (71-E) to Main Front Frame (N) using:
Two 2 (M10x115 partial thread allen head bolt)
Four 69 (pulley spacer)
Two 60 (M10 nylon lock nut)
- G. Install Pulley (71-C) to Main Top Frame (C) using:
One 47 (M10x45 partial thread hex head bolt)
Two 101 (M10 washer)
One 60 (M10 nylon lock nut)
- H. Connect (71-A) and (71-B) to Main Top Frame (C) using:
Two 47 (M10x45 partial thread hex head bolt)
Four 101 (M10 washer)
Two 60 (M10 nylon lock nut)

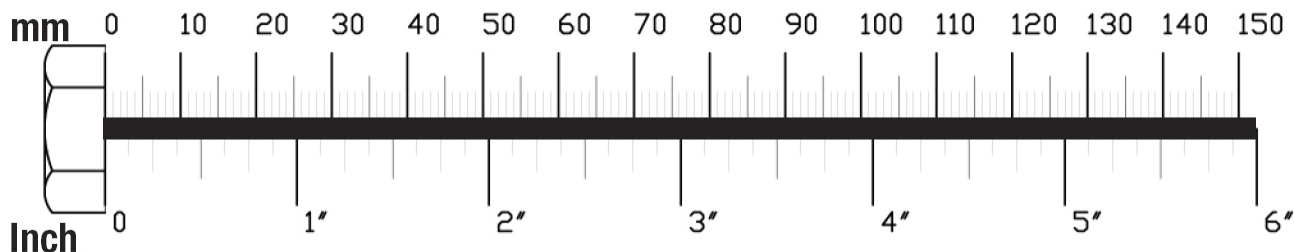

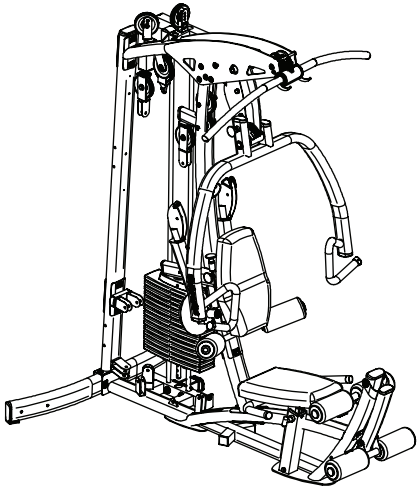

Above shows STEP 8 assembled and completed

Diagram A.

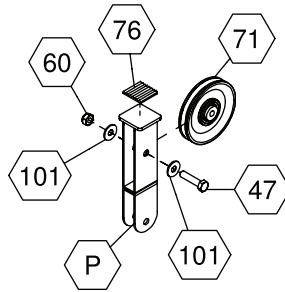

Diagram B.

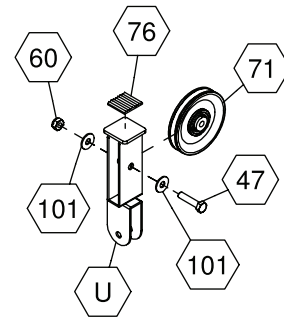
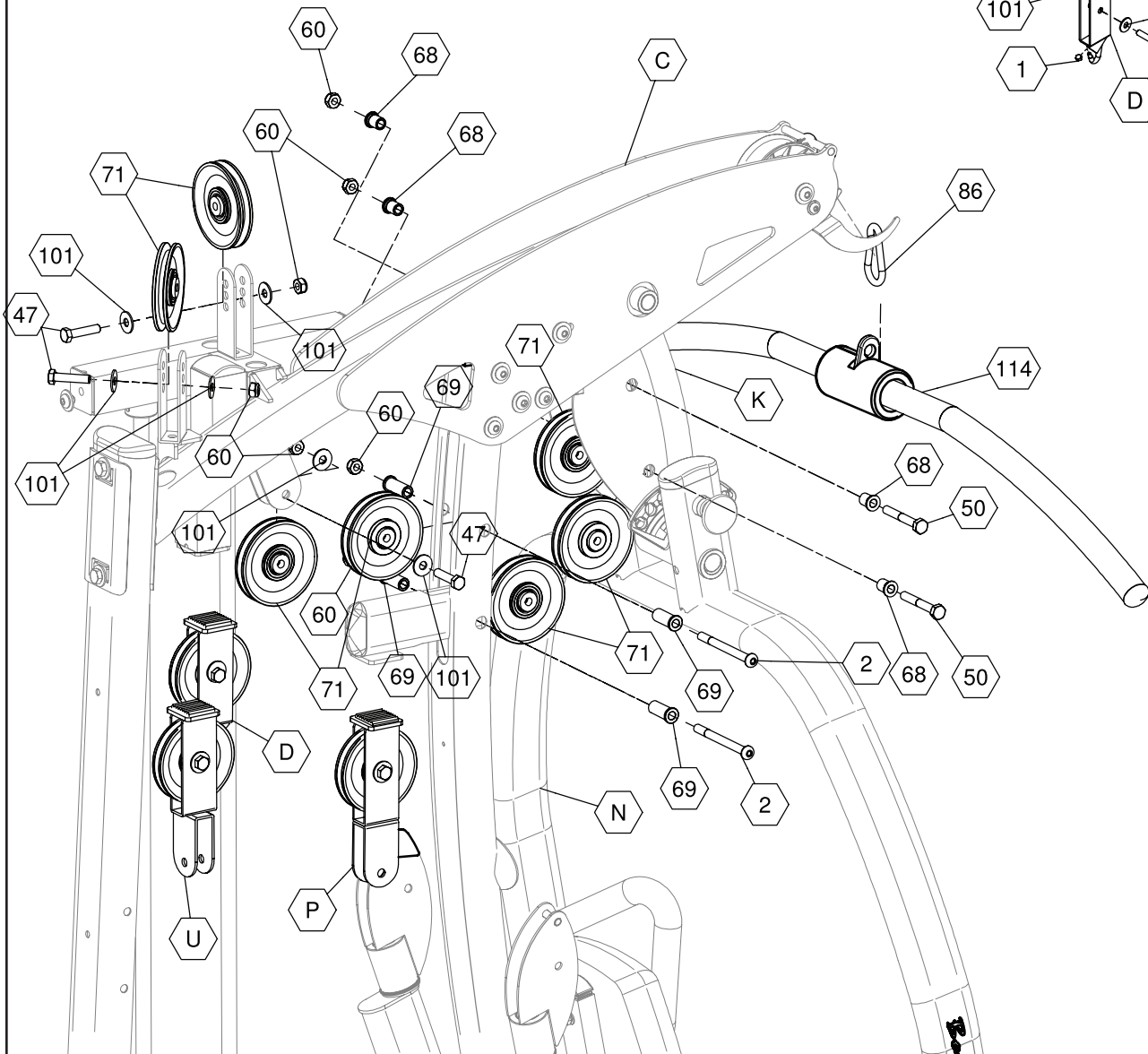
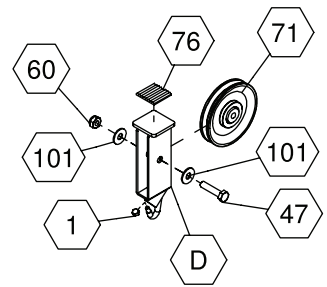

Diagram C.



STEP**9****Be careful to assemble all components in the sequence they are presented.****NOTE:**

Finger tighten all hardware in this step. Do Not wrench tighten until end of step 15. Some components may be pre-assembled.

- A. Begin routing Lat Pull Down Cable (106) with Metal Ball End over and around Pulley (71-H).
- B. Route cable around Pulley (71-G) and up and around Pulley (71-D).
- C. Bring Cable (106) up and around Pulley (71-F) and over Pulley (71-E).
- D. Route Cable (106) through Holder for Double Parallel Pulleys (P) upwards and around Pulley Holder with Stop (D).
- E. Bring Cable (106) down and around Holder for Double Crossed Pulleys (U) then up towards Pulley (71-A).
- F. Bring Cable (106) back down from Pulley (71-A) and around Pulley Holder with Stop (D) back upto Pulley (71-B).
- G. Pull Cable (106) around Pulley (71-B) then down towards the weight stack.
- H. Terminate the Metal Ball End of cable (106) in Selector Rod Top Bolt (79) as shown in the diagram by using:
One 23 (cable end shaft)
One 12 (M4x8 allen screw)
One 93 (M10x25 hex head bolt)

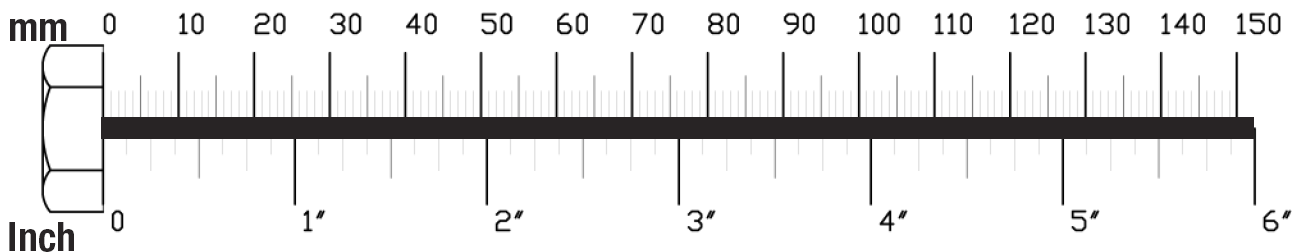

LAT PULLDOWN CABLE (106)

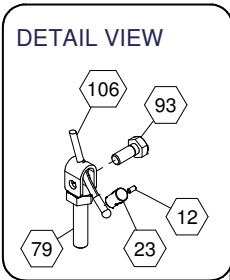
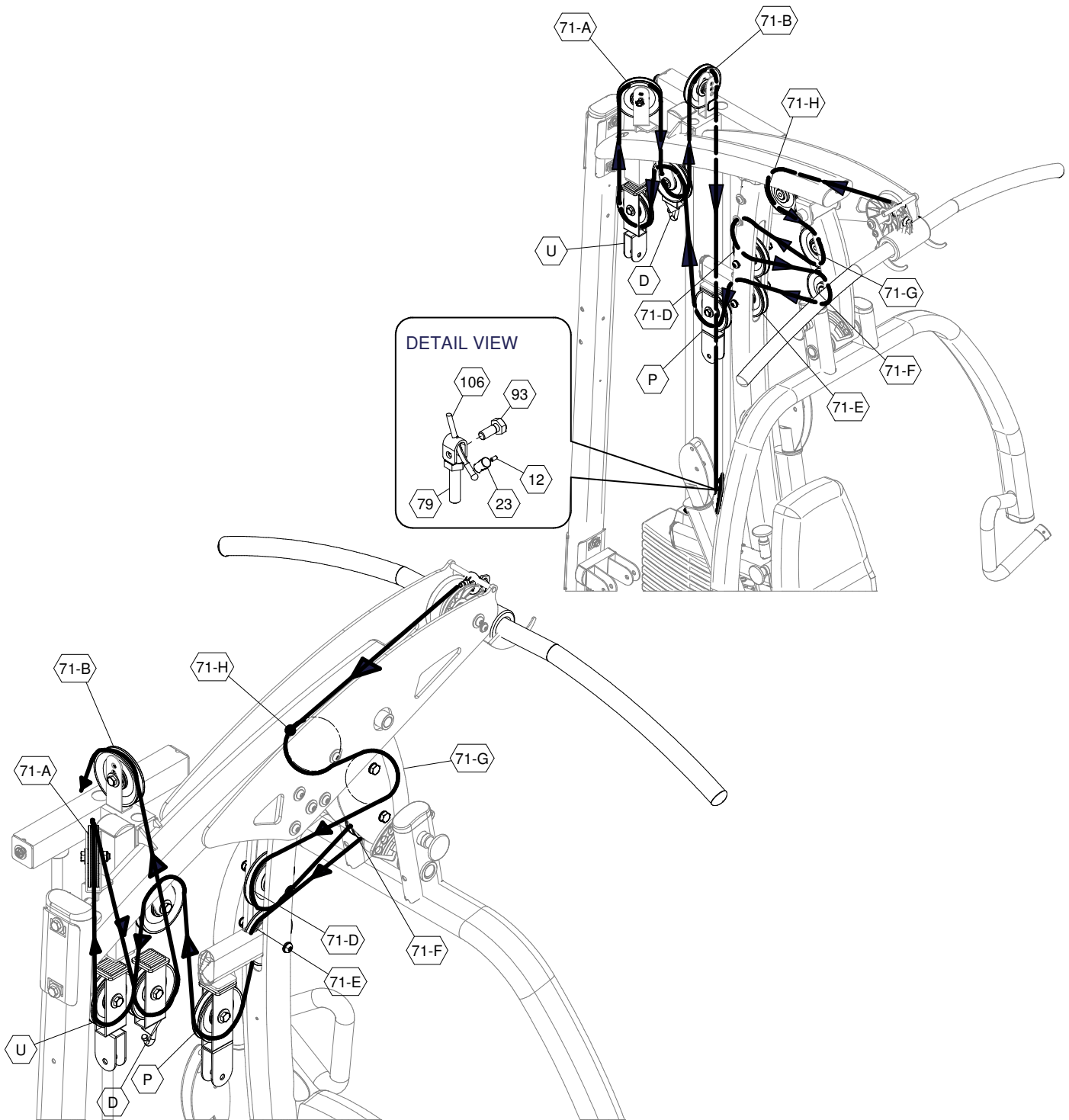
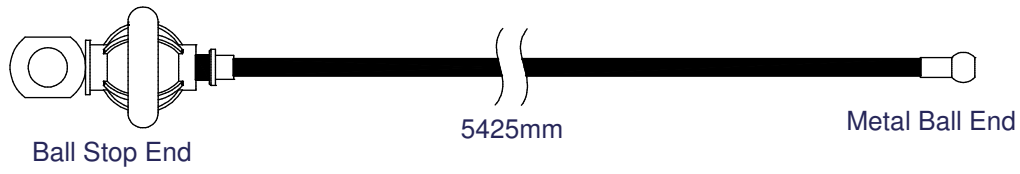

STEP**10****Be careful to assemble all components in the sequence they are presented.****NOTE:**

Finger tighten all hardware in this step. Do Not wrench tighten until end of step 15. Some components may be pre-assembled.

- A. Connect Pulley (71-J) to Holder for Double Parallel Pulleys (P) and Pulley (71-K) to Main Base Frame (A) using:
Two 47 (M10x45 partial thread hex head bolt)
Four 101 (M10 washer)
Two 60 (M10 nylon lock nut)
- B. Connect Pulley (71-M) to Rear Upright Frame (B) as shown in the diagram using:
One 49 (M10x70 partial thread hex head bolt)
Two 101 (M10 washer)
One 60 (M10 nylon lock nut)
- C. Connect Pulley (71-L) to Functional Training Arms Rear Pulley Support (AA) using:
One 47 (M10x45 partial thread hex head bolt)
Two 101 (M10 washer)
One 60 (M10 nylon lock nut)
- D. Connect Snap Link (86) to Leg Extension Cable (107) as shown in the diagram.
- E. Connect Pulley (71-N) to Main Base Frame (A) using:
One 2 (M10x115 partial thread allen head bolt)
Two 69 (pulley spacer)
One 60 (M10 nylon lock nut)
- F. Attach Stamped Eye End of Leg Extension Cable (107) to Leg Extension Arm (Z) by using:
One 122 (M10x60 partial thread allen head bolt)
Two 101 (M10 washer)
One 100 (M10 washer)
One 60 (M10 nylon lock nut)

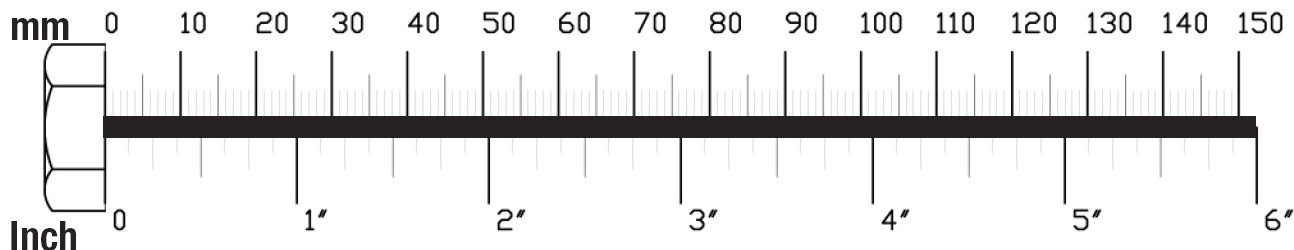

STEP
10

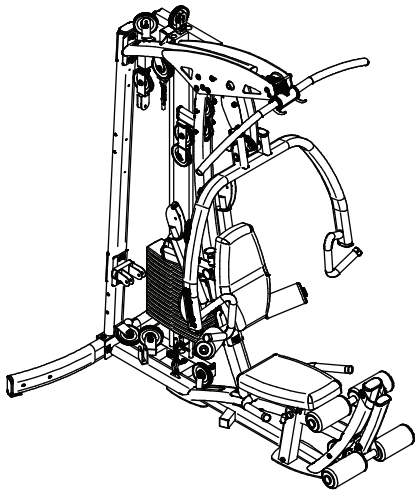

Above shows STEP 10
assembled and completed

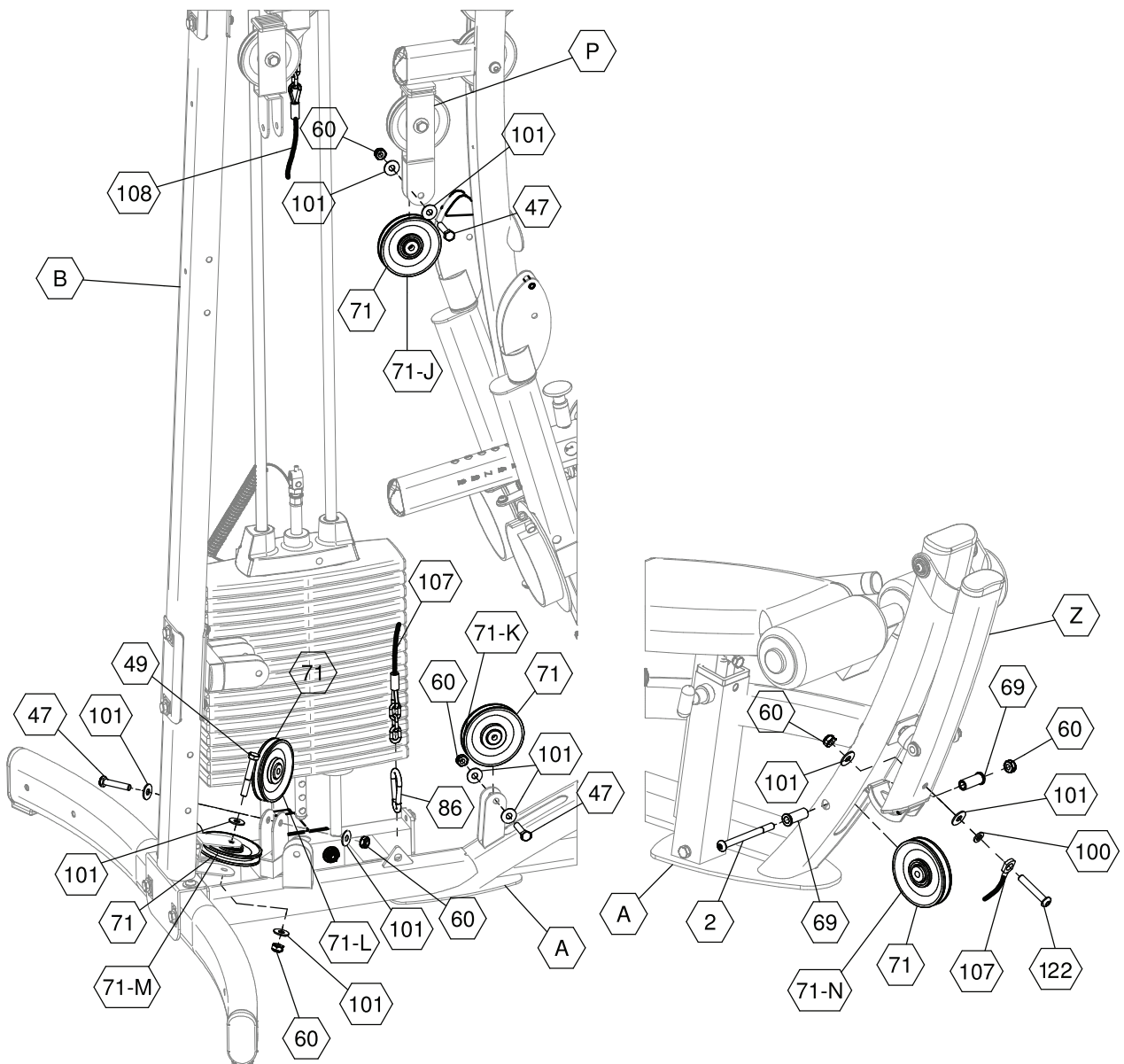

STEP**11****Be careful to assemble all components in the sequence they are presented.****NOTE:**

Finger tighten all hardware in this step. Do Not wrench tighten until end of step 15. Some components may be pre-assembled.

- A. With Stamped Eye End of Leg Extension Cable (107) attached, route Cable (107) under Pulley (71-N) and around (71-K).
- B. Pull Cable (107) upwards towards Pulley (71-J), around then down terminating at eyehole in Main Base Frame (A).
- C. Connect Chain End of Cable (108) to Pulley Holder with Stop (D) and secure by using Acorn Cap Nut (1).
- D. Route Cable (108) down and around Pulley (71-L) and terminate around Pulley (71-M)

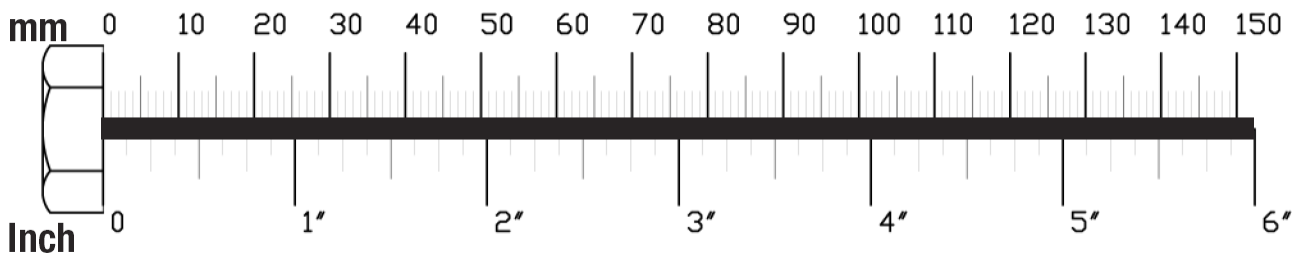

LEG EXTENSION CABLE (107)



LEFT ATTACHMENT CABLE (108)

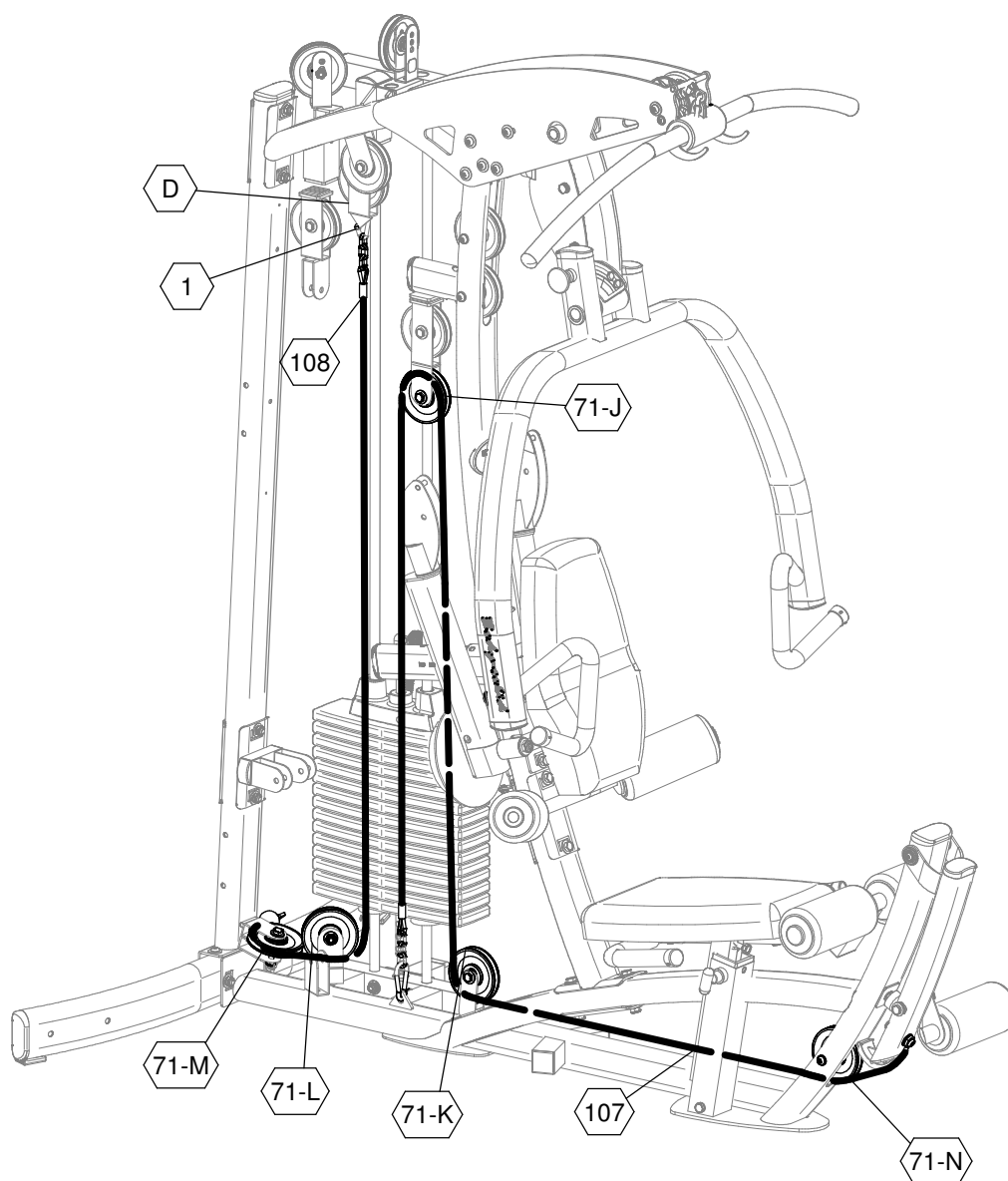
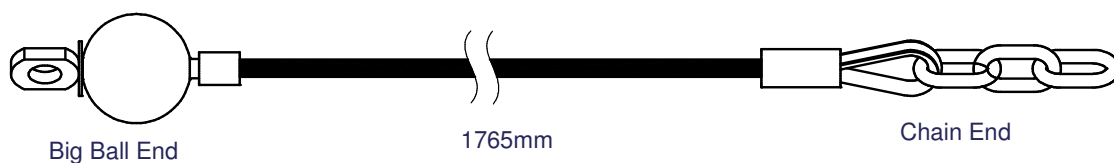

Be careful to assemble all components in the sequence they are presented.

NOTE:

Finger tighten all hardware in this step. **Do Not** wrench tighten until end of step 15. Some components may be pre-assembled.

- A. Route both Turn Plate Cables (110) as shown in the detail view. Make sure cables are secure by tightening both Jam Nuts (57).
- B. Install Pulleys (71) into both Pulley Holder (R) by using:
Two 47 (M10x45 partial thread hex head bolt)
Four 101 (M10 washer)
Two 60 (M10 nylon lock nut)
- C. Assemble Pulleys (71-Q) and (71-R) to Functional Training Arms Rear Pulley Support (AA) by using:
Two 47 (M10x45 partial thread hex head bolt)
Four 101 (M10 washer)
Two 60 (M10 nylon lock nut)
- D. Install Pulley (71-P) as shown in the diagram using:
One 49 (M10x70 partial thread hex head bolt)
Two 101 (M10 washer)
One 60 (M10 nylon lock nut)
- E. Install Pulley (71-O) by using
One 104 (M10x50 partial thread hex head bolt)
Two 101 (M10 washer)
One 60 (M10 nylon lock nut)
One 100 (M10 washer)

Note:

Cable (105) will terminate and be attached to Pulley Assembly as shown in the diagram.

- F. Insert Pulleys (72) into Turn-Plate Cam and attach using:
Two 48 (M10x55 partial thread hex head bolt)
Four 67 (pulley spacer)
Two 60 (M10 nylon lock nut)
- G. Attach Pullet (71-U) to Holder for Double Crossed Pulleys (U) using:
One 47 (M10x45 partial thread hex head bolt)
Two 101 (M10 washer)
One 60 (M10 nylon lock nut)
- H. Install Pulley (71-S) and (71-T) to Right Functional Training Arm (X) and left Functional Training Arm (W) using:
Two 47 (M10x45 partial thread hex head bolt)
Four 101 (M10 washer)
Two 60 (M10 nylon lock nut)

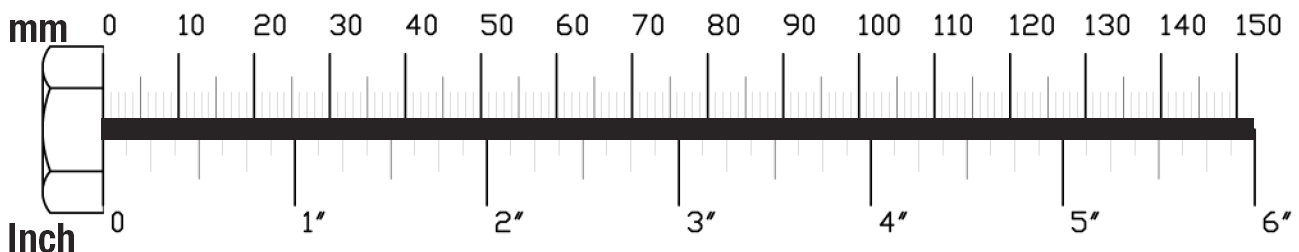

STEP 12

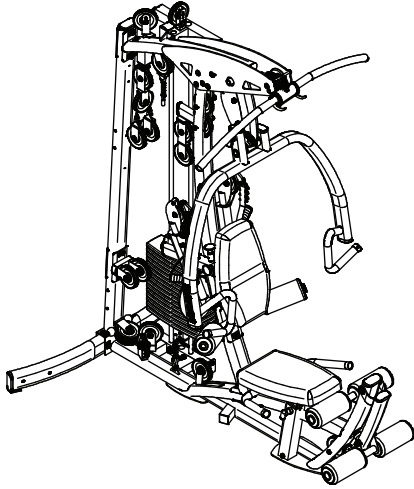

Above shows STEP 12 assembled and completed

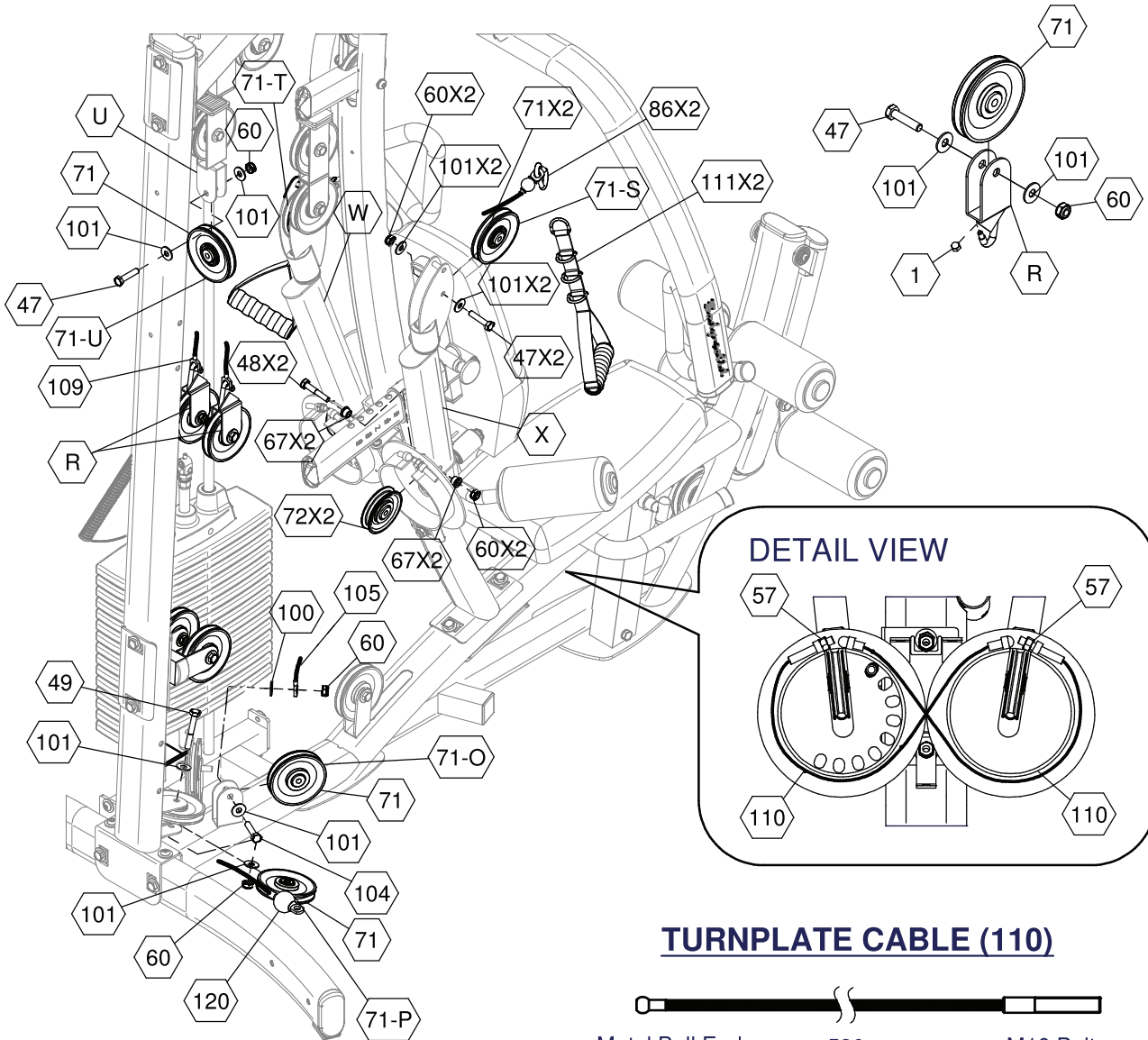
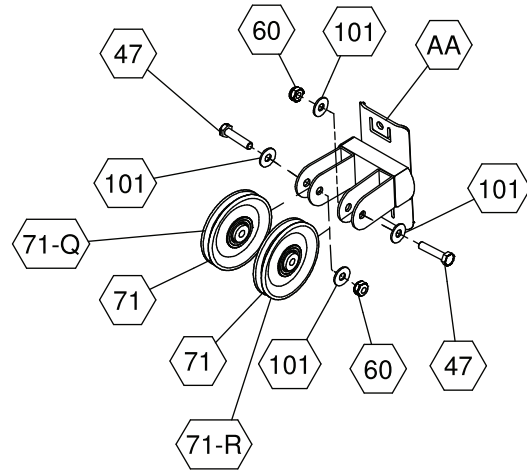

DETAIL VIEW

TURNPLATE CABLE (110)



STEP**13****Be careful to assemble all components in the sequence they are presented.****NOTE:**

Finger tighten all hardware in this step. Do Not wrench tighten until end of step 15. Some components may be pre-assembled.

- A. Attach Short Cable (109) to Pulley (71-U) as shown in the diagram.
- B. Route Cable Right Attachment Cable (120) around Pulley (71-O) and up to Pulley Holder (R).
- C. Bring Right Attachment Cable (120) down from Pulley Holder (R) and around Pulley (71-Q) towards Cam.
- D. Route Right Attachment Cable (120) into Cam and around Pulley (72) and terminate at Pulley (71-S).
- E. Route Functional Training Arm Cable (105) from Pulley (71-T) down towards Pulley (72).
- F. Bring Functional Training Arm Cable (105) out of Cam and around (71-R) then up towards Pulley Holder (R).
- G. Route Functional Training Arm Cable (105) around Pulley Holder (R) then back down and terminate at Pulley (71-O) as shown in Step 12 and detail view.

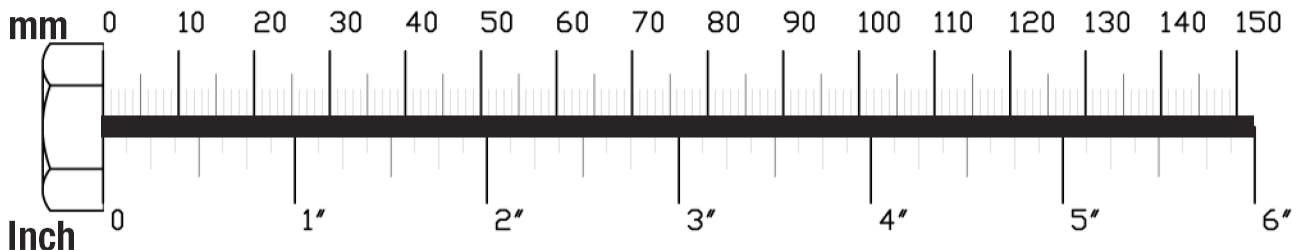

FUNCTIONAL TRAINING ARM CABLE (105)



RIGHT ATTACHMENT CABLE (120)



SHORT CABLE (109)

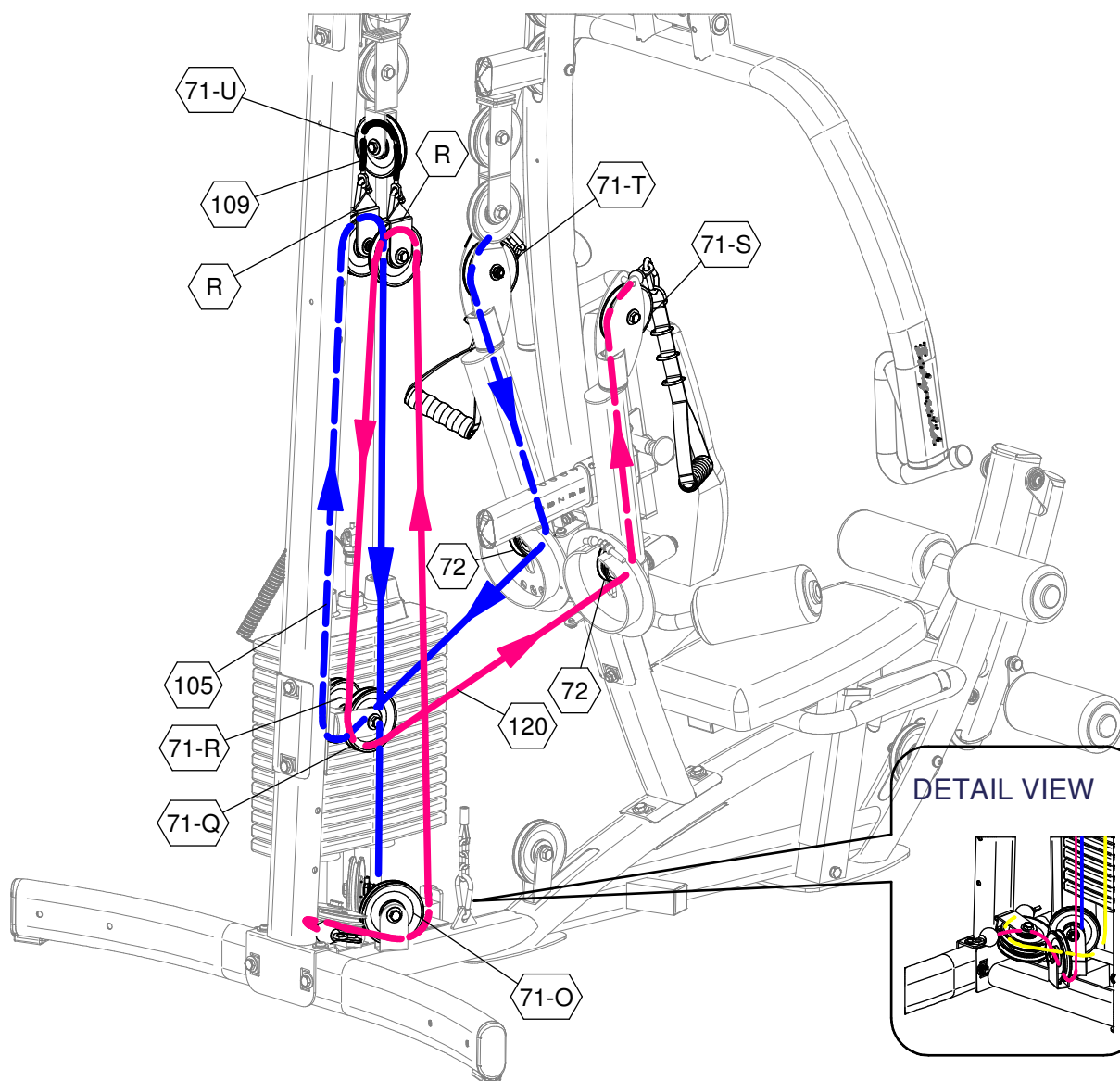

STEP**14****Be careful to assemble all components in the sequence they are presented.****NOTE:**

Finger tighten all hardware in this step. Do Not wrench tighten until end of step 15. Some components may be pre-assembled.

- A. Install Functional Training Cover (43) to the Cam by using:
Three 10 (M8x10 allen head bolt)
Three 103 (M8 washer)
- B. Slide Plastic Pad (118) into Functional Training Cover (43) to reinforce openings.
- C. Install Front Shroud (AB) and Back Shroud (AC) around Weight Stack and Assemble using:
Four 4 (M10x10 allen head bolt)
Four 101 (M10 washer)

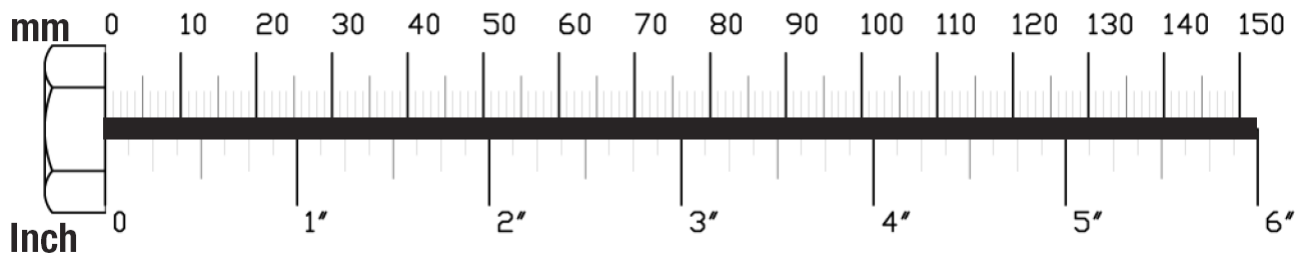

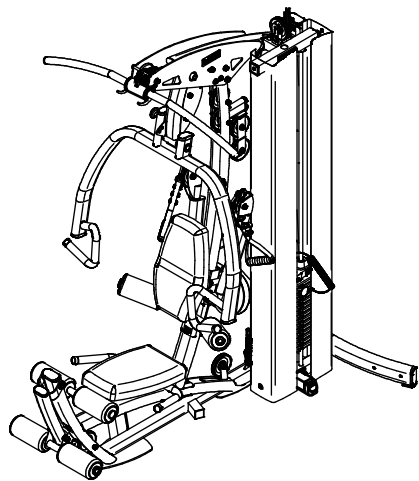

Above shows STEP 14 assembled and completed

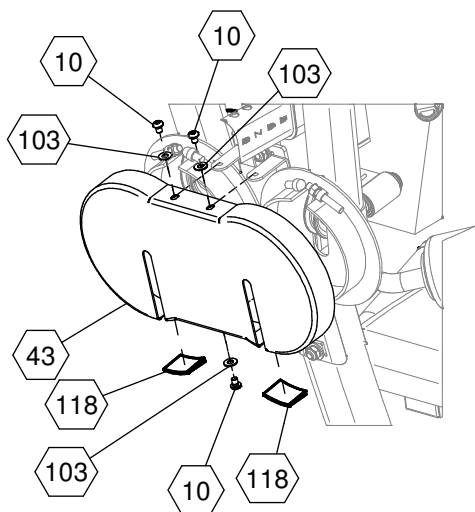
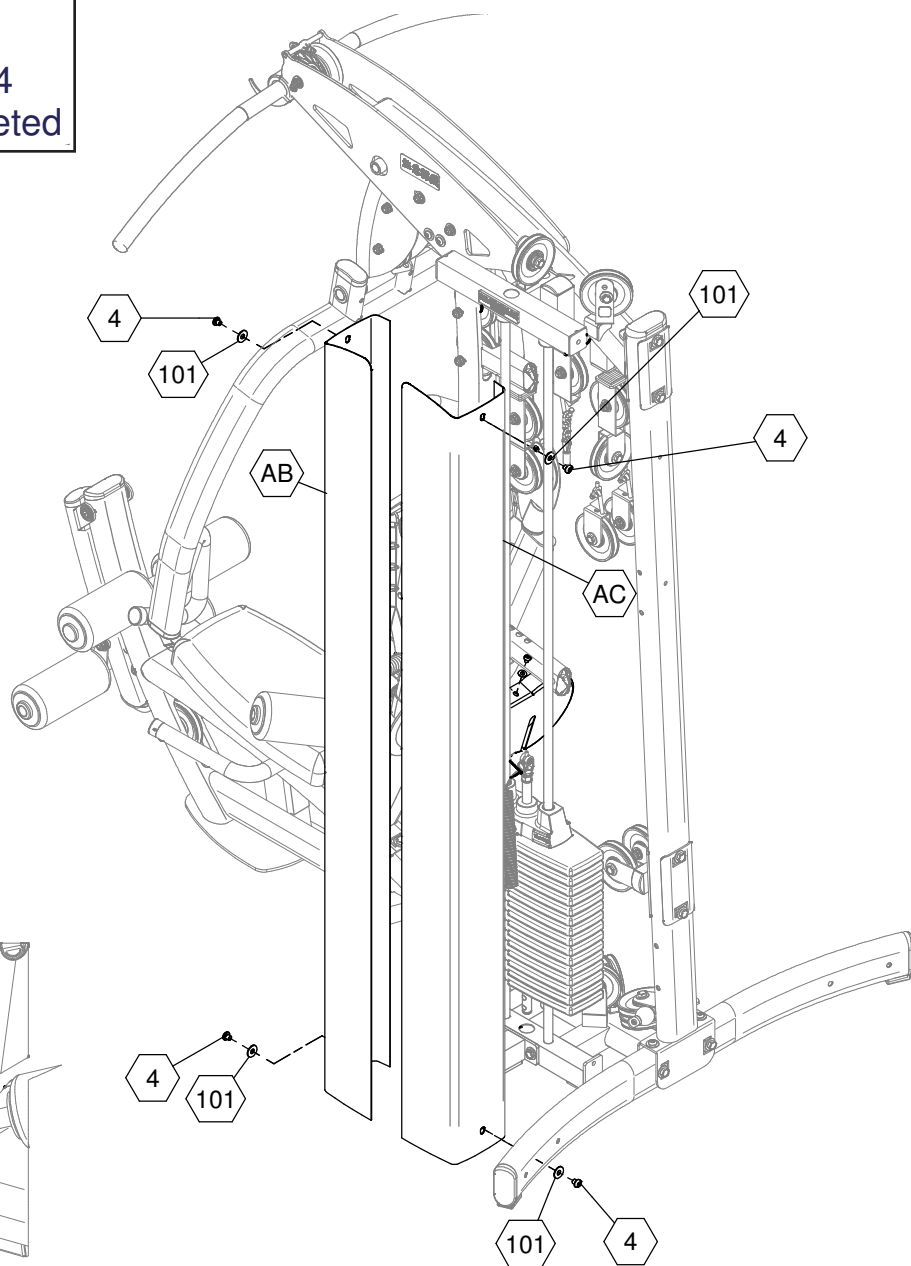

STEP**15**

Be careful to assemble all components in the sequence they are presented.

NOTE:

Finger tighten all hardware in this step. Do Not wrench tighten until end of step 15. Some components may be pre-assembled.

- A. Insert Flat End Cap (34) into Side Leg Hold Down Frame (V).
- B. Insert Side Leg Hold Down Frame (V) into Main Base Frame (A).
- C. Attach Rubber Pads (84) to Side Leg Hold Down Frame (V).

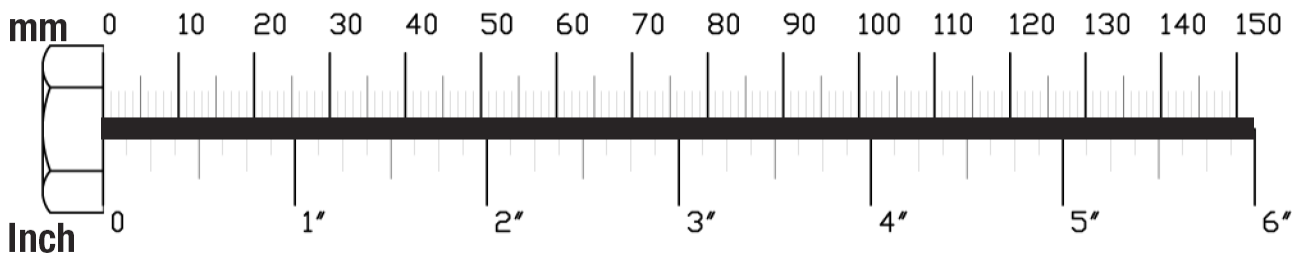

STEP
15

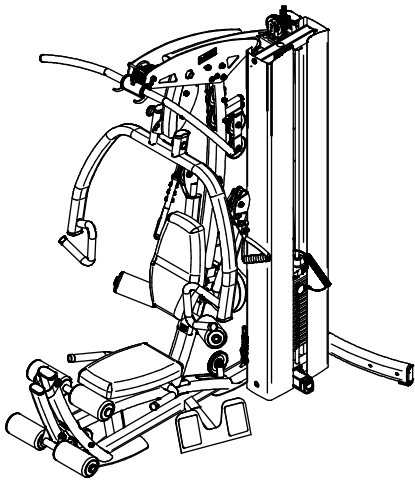

Above shows STEP 15
assembled and completed

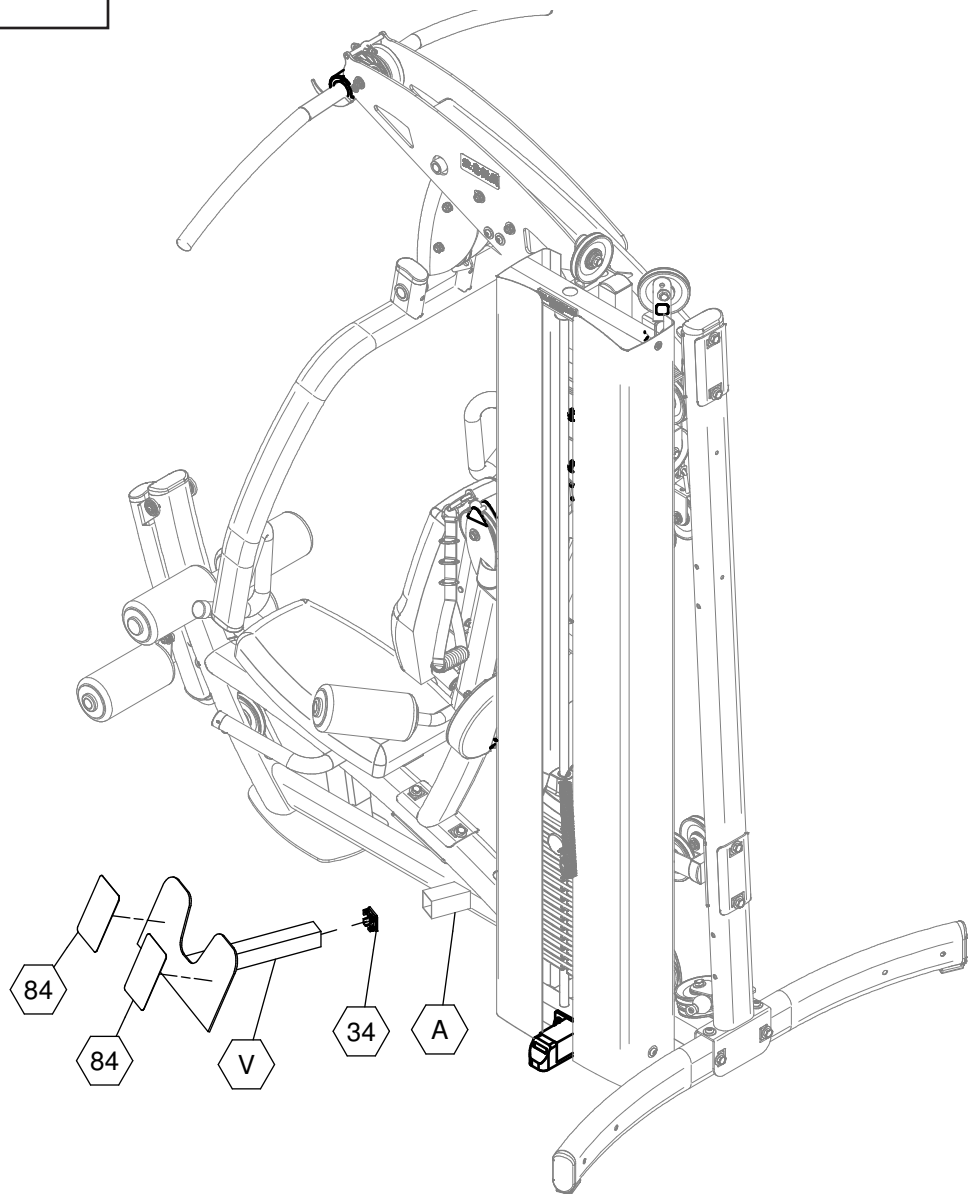

Warnings, Safety & Maintenance

Be sure that all users carefully read and understand all warning, safety and maintenance labels on the machine before each use. Failure to do so may result in serious injury. It is imperative that you retain this Owner's Manual and be sure all warning labels are legible and intact. Replacement Owner's Manuals and labels are available from your local Body-Solid dealer. If you have any questions about the operation, set up or maintenance of this machine please call our customer service department at 1 (800) 556-3113

THERE IS A RISK ASSUMED BY INDIVIDUALS WHO USE THIS TYPE OF EQUIPMENT. TO MINIMIZE RISK, YOU MUST FOLLOW THESE RULES:

1. Inspect equipment before each workout. Check that all nuts, bolts, screws and pop pins are in place and fully tightened. Also, before use, check cables for signs of wear. Replace all worn parts immediately. Never use machine if any parts are damaged or missing. **FAILURE TO FOLLOW THESE RULES MAY RESULT IN SERIOUS INJURY.**
2. Keep clear of the cables and all moving parts when the machine is in use.
3. Always make sure all Snap Links are closed when doing any cable/pulley/strap exercises.
4. Exercise with care. Perform your exercises at a smooth moderate pace; never perform jerky or uncoordinated movements that may cause injury.
5. It is recommended that you should workout with a training partner.
6. Do not allow children or minors to play on or around this equipment.
7. If unsure of proper use of equipment, call your local Body-Solid distributor or the Body-Solid customer service department at 1-800-556-3113.
8. **WARNING:** Consult your physician before starting your exercise program. For your own safety, do not begin any exercise program without proper instruction. RAL8-6-03 WC-54

#DWRULE-4
Warning Label for Rules

MAINTENANCE SCHEDULE		D	W
Check the function and integrity of the following components. As noted, inspect equipment before each workout. Replace all damaged, broken or worn components immediately.		A	E
		I	K
		L	L
		Y	Y
Cables:	Check tension, end fittings, and coating	✓	
	Check that locking nut at weight stack is tight		✓
Upholstery:	Wipe down and dry	✓	
	Clean and condition		✓
Frame:	Wipe down and dry	✓	
	Polish / Wax		✓
Chrome:	Wipe down and dry	✓	
	Polish / Lubricate		✓
Nuts / Bolts / Fasteners:	Tighten and / or adjust as needed		✓
Guide Rods:	Lubricate and clean		✓
Linear Rods:	Lubricate and clean		✓
Seat Sleeves:	Lubricate and clean		✓
Adjustments / Locking Pins / Tightening Knobs			✓
Weight Stack Pins			✓
Warning Instruction Labels			✓
Springs / Pop Pins		✓	
Anti Skid Surfaces			✓
Hand Grips / Rollers			✓

For Body-Solid Customer Service
Call 1-800-556-3113
#MSSTKR0803

#DWSM-5
Warning Label for Maintenance

Warnings, Safety & Maintenance

Precision craftsmanship assures Body-Solid's ability to consistently deliver products of the highest standards. Our products have been carefully designed to ensure safe, efficient long term operation.

However, it must be realized that safe use of this equipment requires that owners carefully read and follow the Body-Solid use recommendations, warnings, and maintenance guidelines in this Owners Manual.

Routine inspection and maintenance is of critical importance to ensure the maximum safety and performance of the Fusion 500. Body-Solid uses the highest quality materials available, but wear is inevitable. Therefore, you must carefully inspect your equipment as outlined in the Maintenance Schedule on the next page.

Be advised that dangerous conditions can arise even during a warranty period. A warranty does not negate the owner's responsibility to thoroughly, carefully and daily inspect the machine.

Including maintaining the equipment the owner's responsibility is also to:

- Be sure to always provide adequate supervision to all end-users.
- Be sure to instruct all end-users of proper usage.
- Be sure all supervisors and personal trainers who instruct end-users on equipment are properly trained and know the function and importance of every adjustment and setting. Also, be sure these trainers provide proper instruction to end-users on the fundamentals of strength training.

CABLES:

- While the machine is not in use. Carefully run your fingers along the cable to feel for thinning or bulging areas. Replace cables immediately at the first sign of damage or wear. Do not use equipment until damaged cable has been replaced.
- Visually inspect the cables for fraying, cracking, peeling or discoloration.
- Check slack in cables and re-adjust cable tension if needed.
- Check that jam nut at Weight Stack is tight.

UPHOLSTERY:

- Wipe down after every workout.
- Periodically take the time to use a mild soap or a mild vinyl upholstery cleaner. Avoid using any abrasive cleaner not intended for use on vinyl.
- Keep sharp or pointed objects out of your pockets and clear of all upholstery.

NUTS/BOLTS/FASTENERS:

- Periodically inspect all nuts and bolts. Tighten if needed. If bolts seem to loosen periodically, use Loctite 242 for a long-term cure.
- Go through a re-tightening sequence periodically to ensure that all hardware is properly tensioned.

GUIDE RODS:

- Wipe clean with a dust free rag. Lubricate with a Silicon or Teflon based lubricant.

ADJUSTMENTS / LOCKING PINS /

TIGHTENING KNOBS:

- Check all pieces for signs of visible wear or damage.
- Check springs in Snap Links and Pop Pins for proper tension and alignment.
- If the spring sticks or has lost its rigidity, replace it immediately.

ANTI-SKID SURFACES:

- Replace if they appear worn or become slippery.

WARNING INSTRUCTION LABELS:

- Inspect and familiarize yourself with all safety warnings and other user information on decals.

Body-Solid

MAINTENANCE SCHEDULE	DAILY	WEEKLY	LATEST DATE ENTRY						
CABLES: CHECK TENSION, END FITTINGS, AND COATING. CHECK THAT JAM NUT AT WEIGHT STACK IS TIGHT.	✓	✓							
UPHOLSTERY: WIPE DOWN AND DRY CLEAN AND CONDITION.	✓	✓							
FRAME: WIPE DOWN AND DRY POLISH/WAX	✓	✓							
CHROME: WIPE DOWN AND DRY POLISH/LUBRICATE	✓	✓							
NUTS/BOLTS/FASTENERS: TIGHTEN AND / OR ADJUST AS NEEDED		✓							
GUIDE RODS: LUBRICATE AND CLEAN		✓							
LINEAR RODS: LUBRICATE AND CLEAN		✓							
SEAT SLEEVES: LUBRICATE AND CLEAN		✓							
ADJUSTMENTS / LOCKING PINS / TIGHTENING KNOBS		✓							
WEIGHT STACK PINS		✓							
WARNING INSTRUCTION LABELS		✓							
SPRINGS / POP PINS	✓								
ANTI-SKID SURFACES		✓							
HAND GRIPS / ROLLERS		✓							
FOR BODY-SOLID CUSTOMER SERVICE: 1-800-556-3113	*Make several copies of this page to keep track of your maintenance. You can print more copies of this page by going to: http://www.bodysolid.com/support/docs.html								

Body-Solid

PHRASES, TERMS, TIPS & GUIDELINES

BEGINNER'S GUIDELINES

- Work out at least two times a week.
- Include six to eight exercises that train major muscle groups.
- Perform two or three sets of at least eight to 12 repetitions.



AEROBIC

Exercise that primarily uses oxygen to burn fuel at low to moderate levels of intensity. Running and jogging are examples of aerobic exercise.

ANAEROBIC

Exercise that primarily uses the body's stored fuel for energy. Intense weightlifting is an example of an anaerobic exercise.

ATROPHY

Decrease of a muscle caused by the decrease in the size of its cells because of inactivity.

BALLISTIC STRETCHING

A stretching technique that involves a bouncing or bobbing movement during the stretch. The final position is not held. This is not a recommended stretching technique.

BREATHING

Never hold your breath during any part of an exercise. Holding your breath may cause severe intra-thoracic pressure and raise blood pressure leading to dizziness, blackout or other complications. The rule of thumb is to exhale on exertion and inhale on the return part of the exercise.

CARDIOVASCULAR

Referring to the heart, lungs, and other periphery systems involved in the transport of oxygen throughout the body.

CHALLENGE YOUR MUSCLES

All strength training should progress gradually, using increases in weight until your goals are reached. Then, change your workout to include increased reps or a higher weight resistance. Alter the order of your exercises, perform multiple sets or different exercises to maintain results or reach new goals.

CHANGE ROUTINE

Beginner's please note: If you want to make changes in the exercise routine that you do, wait until about the six to eight week point. Advanced lifters may want to change routines to avoid plateaus in gaining size or strength.

CIRCUIT TRAINING

Exercise stations that consist of various combinations of weight training, flexibility, calisthenics, and aerobic exercise.

CONCENTRIC MUSCLE ACTION

The muscle shortens while contracting against resistance.

ECCENTRIC MUSCLE ACTION

The muscle lengthens while contracting against resistance.

EXERCISE FREQUENCY

Exercise each muscle group 2-3 times per week. Allow a minimum of 48 hours rest for each muscle group worked. If you are doing a total-body workout, three training sessions per week, performed on every second day, is adequate.

EXERCISE LARGE MUSCLES FIRST

You should work your large muscle groups first (ie. squat, bench press, lat pulldown) before you exercise your small muscle groups (ie. bicep curls, tricep pressdowns, lateral raises).

EXERCISE PROGRAM DURATION

A weight training routine should take anywhere from 45 minutes to one hour to complete. Add another 20 to 60 minutes when you include stretching, warm-up, aerobics and cool-down.

GIVE YOUR MUSCLES A REST

You'll get the most out of strength training if you give your muscles at least 48 hours rest to recover and rebuild between strength training workouts.

HYPERTROPHY

Enlargement of a muscle caused by an increase in the size of its cells in response to weight training.

INTENSITY

The degree to which the body is worked during exercise.

ISOKINETIC EXERCISE

Resistance is given at a fixed velocity of movement with accommodating intensity. A machine that moves you through an entire range of motion at a preset speed and will not change no matter how much pressure is put forth by the individual.

ISOMETRIC EXERCISE

Contracts the muscle statically without changing its length. Example: Attempting to lift a weight heavier than you can handle, but cannot move.

ISOTONIC EXERCISE

Shortens and lengthens the muscle through a complete range of motion. This defines weight training with full range of motion.

MUSCLE FATIGUE

Fatigue is when you can't possibly do another rep without sacrificing form.

MUSCULAR ENDURANCE

The ability to perform repetitive muscular contractions against some resistance.

MUSCULAR STRENGTH

The maximum force that can be applied by a muscle during a single maximum contraction.

OSTEOPOROSIS

A decrease in bone density.

PLYOMETRIC EXERCISE

A technique that includes specific exercises which encompass a rapid stretch of a muscle eccentrically, followed immediately by a rapid concentric contraction of that muscle for the purpose of facilitating and developing a forceful explosive movement over a short period of time. Examples of these are using medicine balls for upper extremity and depth jumping for lower extremity.

Body-Solid

PHRASES, TERMS, TIPS

& GUIDELINES

STARTING RESISTANCE LEVEL

If you begin weight training at too high a level, you risk serious injury. You will also develop poor form, which will hinder your efforts and discourage you. Use this as a guideline: if you cannot lift the weight eight times with proper form, the weight is too heavy. Similarly, don't choose too light a weight; the last two or three repetitions of your set should be difficult.

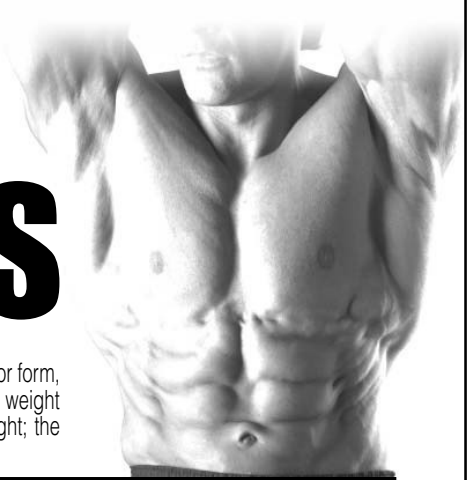

POWER

Power is the rate of performing work. Power during a repetition is defined as the weight lifted times the vertical distance the weight is lifted divided by the time to complete the repetition. Power during a repetition can be increased by lifting the same weight the same vertical distance in a shorter period of time. Power can also be increased by lifting a heavier resistance the same vertical distance in the same period of time as a lighter resistance.

PROGRESS GRADUALLY

Increase reps before increasing resistance. Reduce rest intervals between sets to increase intensity.

PROGRESSIVE RESISTANCE

The principle of continually adding more weight to a specific exercise as your muscles become stronger to adapt to the heavier weights.

PROPER FORM

Focus on the proper motion of the exercise and concentrate on the specific muscles being used. Do not sacrifice proper form to lift heavier weight or to perform more repetitions. Proper form also means lifting in a smooth, fluid motion. If you feel strain elsewhere, you should re-evaluate the amount of weight you are lifting or have a qualified professional critique your exercise motion.

PROPER POSTURE

Maintaining proper posture will greatly reduce chances of injury and maximize exercise benefit. When standing always keep your feet shoulder-width apart. Do not lock your knees. Locking your knees can put unnecessary strain on them. Keep your back flat and straight, making sure not to twist or arch it in order to complete a repetition.

PROPER TECHNIQUE

To get the most out of strength training and to reduce the chance of injury, use proper weight training techniques. These include working your muscles through their full range of motion (but not locking any joints), lifting at a speed at which you can control the weight and stop easily if necessary.

RANGE OF MOTION

Moving through a complete range of motion (ROM) allows the muscles to stretch before contraction and increases the number of muscle fibers being recruited. This produces maximum contraction and force. By working the full ROM, flexibility will be maintained and possibly increased.

REPETITION

A repetition is one complete movement of an exercise. It normally consists of two phases: the concentric muscle action, or lifting of the resistance, and the eccentric muscle action, or lowering of the resistance.

REPETITION MAXIMUM (RM)

This is the maximum number of repetitions per set that can be performed at a given resistance with proper lifting technique. Thus, a set at a certain RM implies the set is performed to momentary voluntary fatigue. 1RM is the heaviest resistance that can be used for one complete repetition of an exercise. 10 RM is a lighter resistance that allows completion of 10 (but not 11) repetitions with proper exercise technique.

REST INTERVAL

Allow a brief pause between sets to give your muscles a chance to partially recover before working them again. For power and muscle size development allow a 3 to 4 minute rest interval between sets. For muscular endurance and definition allow a 30 second rest interval. For strength training allow a 60 to 90 second rest interval.

RISK SHOULD NOT EXCEED BENEFIT

If the risk of a specific exercise exceeds its potential benefit, it is best to stay on the conservative side. There are several ways to work specific muscle groups. Choose those that provide minimal risk. Ask a fitness professional for guidance.

ROUTINE

The specific exercises, sets, reps and weight for a specific body part.

SET

This is a group of repetitions performed continuously without stopping. While a set can be made up of any number of repetitions, sets typically range from 1 to 15 repetitions.

SMALL MUSCLE GROUP EXERCISE

Single joint movement and isolation exercises (i.e. bicep curls, tricep pressdowns and leg extensions).

SPEED OF MOVEMENT

Strength training movements should be slow and controlled. Do not use momentum to complete an exercise movement. Momentum puts unnecessary stress on tendons, ligaments and joints. Using momentum in your exercise movements does not develop increased strength.

STATIC STRETCHING

A stretching technique that involves holding a specific muscle or muscle group at a desired length for a certain period of time. This type of stretching is highly recommended.

STOP TRAINING IF YOU FEEL PAIN

If you feel pain during a specific exercise stop immediately. Any continuation may aggravate an existing injury. Re-evaluate your routine to make sure that you are doing a proper warm up. Decrease the amount of weight you are lifting. Talk to a qualified personal trainer, health professional or your doctor.

STRENGTH

Strength is the maximal amount of force a muscle or muscle group can generate in a specified movement pattern at a specified velocity of movement.

WARM UP

This cannot be stressed enough. Many workout-related injuries can be avoided by a proper warm up routine. Try to do a total body warm up before you start training. A good example of a total body warm up is using a stationary bike, treadmill, elliptical, rowing or skiing machine. It is especially important to warm up specific muscle groups you are going to be using. Your muscles need a 5 to 15 minute warm up as well as a brief cool down. This can be as simple as performing a warm up set of high repetitions and light weight (25% to 50% of your training weight) for each exercise.

WORKOUT

The routine, specific exercises, weights, sets, and reps for one or more body parts.

Body-Solid

NUTRITION



Good nutrition is a diet in which foods are eaten in proper quantities and with the needed distribution of nutrients to maintain good health. Malnutrition, on the other hand, is the result of a diet in which there is an under consumption, over consumption, or unbalanced consumption of nutrients that leads to disease or an increased susceptibility to disease. What is stated in the above definitions is the fact that proper nutrition is essential to good health. A history of poor nutritional choices will eventually lead to poor health consequences.

There are many substances necessary for the proper functioning of the body. Nutrients are the substances that the body requires for the maintenance of health, growth, and to repair tissues. Nutrients can be divided into six classes: carbohydrates, fats, proteins, vitamins, minerals and water. Carbohydrates, or "carbs", are nutrients that are composed of carbon, hydrogen and oxygen, and are essential sources of energy in the body. Grains, vegetables, and fruits are excellent sources of carbohydrates. It is recommended that at least 55% to 60% of the total number of calories consumed come from carbohydrates (American Diabetes Association, Diabetes & Exercise, 1990). It is further recommended that 10% or less of the total calories consumed come from simple sugars like a candy bar.

One of the many benefits of consuming foods that are high in complex carbohydrates, such as rice, pasta, and whole grain breads, is that they also typically contain dietary fiber. Dietary fiber is a term used when referring to substances found in plants that cannot be broken down by the human digestive system. Although fiber cannot be digested, it is important in helping to avoid cancers of the digestive system, hemorrhoids, constipation, and diverticular disease because it helps food move quickly and easily through the digestive system. It is recommended that people consume 20 to 30 grams of fiber per day (American Diabetes Association, Diabetes & Exercise, 1990). Excellent sources of dietary fiber are grains, vegetables, legumes, and fruit.

Fats are an essential part of a healthy diet and serve vital functions in the human body. Among the functions performed by fats are temperature regulation, protection of vital organs, distribution of some vitamins, energy production, and formation of component parts of cell membranes. Like carbohydrates, fats are composed of carbon, hydrogen, and oxygen. However, their chemical structure is different.

Both animals and plants provide sources of fat. Saturated fats come primarily from animal sources and are typically solid at room temperature. Plant sources of saturated fats are palm oil, coconut oil, and cocoa butter. A high intake of saturated fats is directly related to increased cardiovascular disease. Unsaturated fats are typically liquid at room temperature. Corn, peanut,

canola, and soybean oil are sources of unsaturated fats. It is recommended that no more than 30% of one's diet be composed of fats. Ten percent or less of the total calories consumed should come from saturated fats. One way to reduce saturated fat intake would be to substitute margarine for butter.

Proteins are substances composed of carbon, hydrogen, oxygen, and nitrogen. Proteins are made by combining amino acids. Amino acids are nitrogen-containing building blocks for proteins that can be used for energy. Amino acids can combine in innumerable ways to form proteins, and it is estimated that tens of thousands of different types of proteins exist in the body. It is the ordering of the amino acids that provides the unique structure and function of proteins.

There are proteins in both meat products and plant products. Animal sources of protein such as milk, meat and eggs contain the eight essential amino acids (amino acids that the body cannot synthesize and therefore must be ingested). Plant sources of protein such as beans, starchy vegetables, nuts, and grains do not always contain all eight amino acids. Because of this, vegetarians must consume a variety of protein-containing foods. It is recommended that proteins make up 10% to 15% of one's daily calories. This will ensure adequate protein for growth, maintenance, and the repair of cells. Protein requirements for adults are not as high as those recommended for infants, children, and young adults. Note: individuals who are training intensely will have an increase in their protein requirements.

Vitamins are organic substances that are essential to the normal functioning of the human body. Although vitamins do not contain energy to be used by the body, these substances are essential in the metabolism of fats, carbohydrates and proteins. Because of the critical role vitamins play, it is necessary that they exist in proper quantities in the body.

Minerals are inorganic molecules that serve a variety of functions in the human body. The minerals that appear in the largest quantities (calcium, phosphorus, potassium, sulfur, sodium, chloride, and magnesium) are often called macrominerals. Other minerals are also essential to normal functioning of the body, but because they exist in smaller quantities (chromium, iron, copper, fluoride, iodine, manganese, molybdenum, selenium, and zinc) they are called microminerals.

A mineral that is often consumed in inadequate amounts by Americans is calcium. Calcium is a mineral important in the mineralization of bone, muscle contraction, and the transmission of nerve impulses. Osteoporosis is a disease characterized by a decrease in the total amount of bone mineral in the body and by a decrease in strength of the remaining bone. This

condition is most common in the elderly but may also exist in younger people who have diets inadequate in calcium or vitamin D or both.

Iron is another mineral that is often under consumed by Americans. This is especially true of women. The oxygen-carrying properties of hemoglobin (blood) depend on the presence of iron. Anemia is a condition characterized by a decreased capacity to transport oxygen in the blood, and is also common in those lacking a sufficient amount of iron intake. Red meat and eggs are excellent sources of iron. Additionally spinach, lima and navy beans, and prune juice are excellent vegetarian sources of iron.

Sodium, on the other hand, is a mineral that many Americans over-consume. High sodium intake has been linked with hypertension, as well as high blood pressure. People can substantially reduce their sodium intake by limiting consumption of processed foods and decreasing the amount of salt added to foods when cooking.

In conclusion...don't forget hydration. Water is considered an essential nutrient because of its vital role in the normal functioning of the body. Water contributes approximately 60% of the total body weight and is essential in creating an environment in which all metabolic processes occur. Water is necessary to regulate temperature and to transport substances throughout the body.

FOLLOW THESE BASIC NUTRITIONAL GUIDELINES FOR GAINS IN STRENGTH AND LEAN MUSCLE MASS:

- 1. Choose your foods carefully. Try getting your carbohydrates from sources such as rice, vegetables, beans, whole grains, pasta and fruit. Good protein sources include fish, chicken, turkey, lean meat and low-fat or nonfat dairy products.**
- 2. Minimize your fat intake.**
- 3. Drink a minimum of 10 eight-ounce glasses of water each day.**
- 4. Eat four to six small meals a day, about three hours apart. Small meals are more easily digested and result in greater nutrition absorption.**
- 5. Avoid eating junk food and fast food.**
- 6. Time your protein intake of 40-55 grams approximately 75 minutes after your workout.**
- 7. Immediately following your workout, replenish your glycogen stores with approximately 50-75 grams of carbohydrates.**

For more information on nutrition visit your local library or book store. There are many excellent books available.

Body-Solid

EXERCISE PRESCRIPTION



Sets

Sets are defined as a combination of any number of reps of one exercise. The number of sets used in a workout is directly related to training results. Typically, two to three sets are used by intermediate and advanced lifters to achieve optimum gains in strength. Experts agree that multiple-set systems work best for the development of strength and muscular endurance. Gains will be made at a faster rate by using a multiple-set system than gains achieved through a single-set system. The use of a single set of an exercise is recommended and very effective for individuals who are untrained or just beginning a resistance training program. One-set programs might also be used for simple maintenance once you are in shape. It is important to note that low-volume set programs will increase strength in untrained individuals, but more complex physiological adaptations, such as gains in muscle mass, tone, size, and performance usually requires higher-volume set training for the best results. Multiple sets of an exercise present a more intense training stimulus to the muscles during each set. Once your desired initial fitness level has been achieved, multiple-set performances of the exercise using the proper resistance (with specific rest periods between sets) will take you to the next level of strength training, endurance, and muscular development.

Resistance Used

The amount of resistance used for a specific exercise is probably the most important variable in resistance training. When designing a resistance training program, a weight for each exercise must be chosen. The use of repetition maximums (RM): the exact resistance that allows only a specific number of repetitions to be performed, is probably the easiest method for determining a resistance. Typically, one uses a training RM target or a RM target zone. Example: If your RM zone is 8 to 12 repetitions and you cannot lift the weight at least 8 times using proper form, the weight is too heavy. On the other hand, if you can easily lift the weight 12 times, the weight is too light. In either case, the weight needs to be changed. As the strength level of the lifter changes over time, the resistance is adjusted so a true RM target or target zone resistance is used.

Rest Periods Between Sets and Exercises

One frequently overlooked variable in exercise prescription is the length of the rest period between sets and between different exercises. Your desired fitness goals will normally determine the amount of time you allow your body to rest. Exercises involving high repetitions (15 to 20) and a high number of sets (3 to 4) with short rest periods (30 seconds) between sets will raise metabolic demands. This in turn will burn excess body fat and increase muscular endurance. Short rest periods are a characteristic of circuit weight training, and the resistances used are typically lighter. This type of workout is best for trimming body fat and toning muscle. Exercises with heavier resistance and fewer sets usually have a longer resting period between sets. The results of using this method are normally increased muscular strength and mass. If the desired outcome is to gain overall muscle mass, your exercise prescription should lean toward a higher weight resistance doing 2 to 6 repetitions per set, with a rest period of 3 to 4 minutes between each set.

Rest Periods Between Workouts

The amount of rest between training sessions depends on the recovery ability of the individual. Most experts agree that three workouts per week with one day of rest between sessions allows adequate recovery, especially for the beginner. If the resistance training is not excessive, only moderate amounts of delayed muscular soreness should be experienced one day after the session. As the lifter advances and his or her body is better able to tolerate and recuperate from the resistance exercise sessions, the frequency of training can be increased. Well-conditioned athletes may be capable of, and need training frequencies of 4 to 5 days in a row to improve significantly and achieve their desired goals. When consecutive-training-day sequences are used, it is usually beneficial to do different exercises for the same muscle groups and use different resistances for the exercises. When training is performed on consecutive days, it often involves the use of a split routine (different body parts exercised each day), or a split program (different exercises for the same body part performed each day). There are many books available at the library or your local book store for the intermediate and advanced weight training enthusiast. It is also recommended that you work with a qualified personal trainer to achieve your ultimate goals.

Order of Exercise

Leaders in the field of strength and conditioning believe that working the larger muscle groups first (chest, back, legs), should take priority over training the smaller muscle groups (biceps, triceps, deltoids, calves). The reason behind this exercise order is that the exercises performed in the beginning of the workout are the ones that are going to require the greatest amount of muscle mass to perform. Hence, exercising the smaller muscle groups first will deplete the body of the energy necessary to stimulate the larger muscle groups. Arm-to-leg ordering allows for some recovery of the arm muscles while the leg muscles are exercised. "Stacking" exercises is a common practice among body builders as a way to attempt to bring about muscle hypertrophy. Stacking is loading up different exercises on the same muscle group (ie. standing bicep curls, preacher curls, one arm concentration curls). The exercise order will have a significant impact on the training stimulus stress level in a training session.

Scheduling Training

Finding the time to do it is one of the most difficult aspects of a training program. Once you have established a time to workout you should plan a training routine based on what muscles to involve on which day. As previously discussed, the larger muscle groups such as the chest, back, and legs should take priority over working the smaller muscle groups. Give your muscles at least 48 hours (but no more than 72 hours) of rest in between sessions.

Body-Solid TRAINING TIPS FOR BEGINNER'S

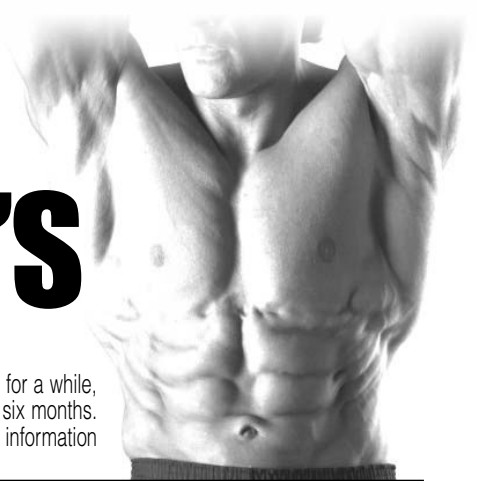

ARE YOU A "BEGINNER" ?

A beginner can be classified as someone who has never touched a weight, may have lifted for a while, but has taken a substantial amount of time off, or has not consistently trained over the last six months. If you happen to fall into any of these categories, pay close attention, because the following information will be detrimental to the start of your training program.

As a beginner, one of the most common mistakes is doing too much. Because beginners often make good gains quickly, many fall into the trap of thinking that more is better. This may be true later in the training equation, but not for the novice. Some of the most common injuries occur as a result of taking on too much, too soon.

One of the questions most frequently asked is, "How much weight should I use?" Determining the weight for each exercise will vary from person to person. The weight for each exercise will be lifted in sets and repetitions. Repetition is defined as one execution of any exercise. A set is a combination of any number of repetitions of one exercise.

Experimentation at each exercise station is a good technique for determining the starting weight for an individual. Take the chest press exercise for example. Performing this exercise with a weight that can be pressed 30 times with ease will not help you achieve any particular goals. Adding the appropriate amount of weight that will allow you to perform a maximum of 8 to 12 repetitions will help you obtain the results you desire.

On the other hand, if you put too much weight on the press bar and press it 4 or 5 times, then common sense will tell you to reduce the weight, wait a few minutes, then try again. Remember, never sacrifice perfect form just for the sake of lifting heavier weight. This is a sure-fire, one-way trip down the road to injury. Making muscles work hard, with proper form is the name of the game.

Now that you understand how to test each station for your starting amount of resistance, you should know which muscles to train first. Training the large muscles groups first, such as your chest, legs, and back, should be done before training your small muscle groups like the arms, shoulders, and calves.

Starting with the large muscle groups will help you achieve and maintain quicker gains. The large muscles groups will require more stimulation and a higher intensity level than the smaller muscle groups. Training your arms with all-out intensity and training your chest immediately afterwards will not leave you with enough energy necessary to properly stimulate the muscle fibers in your chest. Moreover, because the triceps are required in chest press movements, your arm muscles will fail much more quickly than your chest muscles, which will also hold back your chest training.

As a beginner, you will find that your gains will come quickly. The excitement and enthusiasm that comes with these gains may cause you to spend even more time on your gym. Take

it easy! Remember, just as too little exercise won't stimulate muscle growth...too much exercise won't either. You need to give your body plenty of rest, especially if you're still sore from the last workout. This will keep you fresh and growing stronger. **NEVER TRAIN A BODY PART THAT IS STILL SORE FROM THE PREVIOUS WORKOUT.** Performing some flexibility exercises is a good way to keep the blood flowing through the sore area, but do not train these muscles again until you are feeling recovered.

Speaking of soreness, there is something else that you, as a beginner, should be aware of: If you work out - your muscles will get sore. The majority of muscle soreness comes from microtears and a build up of lactic acid in the muscle fibers. This is the result of intense exercise. Muscle soreness can become a problem when the body is pushed too fast and too quickly. As a beginner, tendons, ligaments, joints and tissues have not yet developed the ability necessary to recover from high intensity exercise. A general warm up of stretching and light calisthenics prior to exercise can possibly reduce the amount of post-exercise muscle soreness. A good cool down of stretching and cardio work may also decrease muscle soreness.

Now that we have laid a good foundation of the "do's and don'ts", let's get into something a little more specific. The Beginner's Strength Training Program. One of the best beginner's programs is the three-days-a-week routine. For example, do a whole-body workout on Monday, Wednesday and Friday. Use the other days for rest and recuperation. As previously discussed, you want to start with the large muscle groups first, then move on to the small muscle groups. Perform one exercise per muscle group that consists of 2 or 3 sets of 8 to 12 repetitions. Follow this routine for at least six to eight weeks in order for your body to establish the proper stimulation for growth.

One or two exercises per muscle group may not sound like enough to produce any results, but if you're a beginner - it most definitely will. As you continue to train and your body adapts to your exercise routine and recuperative demands you place upon it, you'll be able to add more sets and exercises to your routine.

Another point that is highly recommended is the assistance of a personal trainer. Through the use of a personal trainer you can learn the mechanics and techniques of exercise, how to use proper form to avoid injury and details on proper nutrition. A good trainer will also provide MOTIVATION.

When choosing a personal trainer, here are some tips: Choose an individual that is certified through an accredited association. This is a good way to ensure that he or she is qualified to give you what you need. Also, take a look at what kind of shape they are in. If you want to be in great shape, look for a trainer who is in great shape. They will know what it takes to get results. Here are a few recommended organizations:

- National Strength & Conditioning (719) 632-6722
- American College of Sports Medicine (317) 637-9200
- National Academy of Sports Medicine (312) 929-5101

SAMPLE WORKOUT ROUTINE WHEN TRAINING FOR STRENGTH

Exercises	Reps	Sets
Leg Press / Squat	8 to 12	2 or 3
Leg Extension	8 to 12	2 or 3
Leg Curl	8 to 12	2 or 3
Calif Raise	8 to 12	2 or 3
Bench / Chest Press	8 to 12	2 or 3
Incline Press	8 to 12	2 or 3
Incline Pec Fly	8 to 12	2 or 3
Lat Pulldown	8 to 12	2 or 3
Seated Row	8 to 12	2 or 3
Military Press	8 to 12	2 or 3
Upright Row	8 to 12	2 or 3
Bicep Curl	8 to 12	2 or 3
Tricep Pressdown	8 to 12	2 or 3
Tricep Extension	8 to 12	2 or 3
Resistance Ab Crunch	20 to 30	2 or 3
Resistance Oblique Crunch	20 to 30	2 or 3

Rest period between sets should be about 60 to 90 seconds.

Body-Solid

COMMON TRAINING MISTAKES



1. Lack of Adequate Warm-Up and Inadequate Flexibility

A warmed muscle is a more flexible muscle that's better able to lift heavier weights and work in a full range of motion. Those warmed muscles also greatly reduce your chance of training injuries.

2. Improper Form

The use of improper form is a good way to keep you out of the gym. Not only does improper form cause injuries, it also doesn't allow for adequate muscle-fiber stimulation.

3. Too Much Weight

Overloading the muscles is a good way to promote muscular growth, but packing on too much weight can cause a snowball effect of improper form, injuries, and down time from your routine.

4. Not Enough Weight

Not lifting enough weight will prohibit the stimulation necessary for muscular growth. Keep challenging yourself to lift heavier weights on a progressive basis always maintaining proper form.

5. Not Enough Rest Between Workouts

If you're still sore from your previous workout, you don't have to go back at it just because it's your scheduled day. Give your body an extra day off to fully recover so when you return you will be able to give 100%.

6. Overtraining

It's not how much time you spend working out, but what you accomplish that really matters. Try to keep your resistance workouts within 45 to 60 minutes per session.

7. Poor Diet and Supplementation

Eating the right combination of foods, along with good supplementation, will greatly promote your success. Make your diet 50 percent carbohydrate, 35 percent protein, 15 percent fat, and take a good multivitamin and protein/carbohydrate supplement. Don't forget the water- at least 80 ounces a day! Hydration is critical.

8. Stale Routines

Your body adapts very quickly to the demands placed upon it. That's why you should have a variety of exercises and routines that you can do. To keep your body growing, you've got to keep it off-guard. Changing your exercises and routines is a sure way to do it.

Body-Solid

SETTING UP YOUR PERSONAL PROGRAM



It is important to first establish specific and realistic goals. You should determine your long term goal and then set a series of short term goals that will help you attain your long term goal. The most common goals are:

Once you have determined your personal goals, you will need to set up a schedule that helps you attain them. Set up a schedule that includes the number of workouts per week, the type of workout activity, the time of day for each workout, and the actual workout program. Don't forget to factor in the warm up and cool down periods. You may have to modify your current lifestyle to accommodate your new schedule. It's very important to include the following basic components to achieve successful results:



Muscular Endurance & Definition

If your personal goals involve losing a considerable amount of body fat you will need to focus more on aerobic exercise and weight training for muscular endurance and definition. If your goals involve a large increase in muscle size you will need to focus on power and muscle mass weight training. Depending on your goals, you will have different nutritional requirements.



Stretching

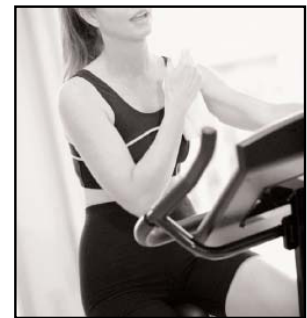

Aerobic Exercise



Increase Strength



Weight Training

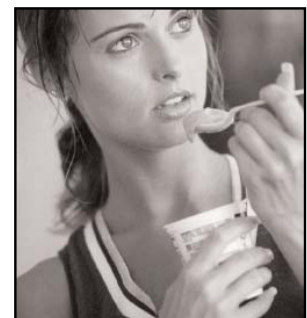

Nutrition



Increase Power & Muscle Mass

Body-Solid

DETERMINE YOUR TRAINING METHOD

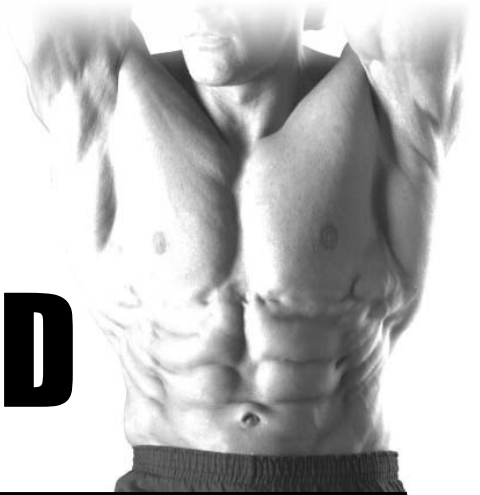

There are three basic types of weight training methods:

1. Training for muscular endurance and definition
2. Training for strength
3. Training for power and muscle mass

You should select a training method that reflects both your present fitness level and your long term goals. You should begin carefully and with proper professional guidance. You can always move from one training method to another as you progress.

If you are beginner, you should start slowly and carefully, gradually increasing the frequency and intensity of your training. Always play it safe – be realistic about your goals and your schedule. Realistic goals are safer and easier to follow.

Which is the right training method for you? First, take a look at your present physique and determine your objectives. Do you want a trim, toned, well-defined body? Are you involved in a sport where speed, strength and power are most important? Maybe you want bulging muscles and a terrific V-shape torso so you look great on the beach. Once you make a decision on what the final results should be, you can set up your personal program using the proper training method to achieve your goals.

Which training method is right for you?

FOR MUSCULAR ENDURANCE & DEFINITION

This training method incorporates achieving and maintaining a high cardiovascular (heart) rate and helps burn away excess fatty tissue. It also adds muscle definition and muscular endurance to your entire body. Exercises are most commonly performed for 15 to 20 repetitions and 3 to 4 sets using a light to moderate weight. The rest period between sets should be about 30 seconds. These short rest intervals will help maintain an elevated heart rate and prevent the muscles from cooling down.

FOR STRENGTH

This type of training is the most popular of the three and is designed specifically for increasing strength throughout the muscle and the muscle-tendon junction. This type of training is especially important for athletes. Normally, exercises are performed using moderate to heavy weight for 8 to 12 repetitions and 2 to 3 sets. The rest period between sets should be from 60 to 90 seconds. This allows a degree of muscle recovery before you hit them again.

FOR POWER AND MUSCLE MASS

This is the method most often used by bodybuilders and is recommended only for the intermediate and advanced lifter. The weights used are heavy — this shocks the muscles and stimulates a more rapid increase in muscle size. Usually exercises are performed for 2 to 6 repetitions and 3 to 4 sets using very heavy weight. The rest period between sets should be from 3 to 4 minutes. The prolonged rest periods allow ample time for recovery between sets.

DESIGNING YOUR PERSONAL ROUTINE

FIRST:

You need to decide which of the above training methods is best suited to accomplish your personal goals.

SECOND:

Study the exercise poster that came with your Body-Solid machine and select one or two exercises per body part (body parts are listed to the left of the exercise pictures). Be sure to include exercises for all body parts. If you leave out certain body parts your exercise routine and your body will not be balanced. If you are trying to increase muscle mass or increase strength to a muscle group it is alright to add extra exercises to the area you are particularly concerned about.

THIRD:

Coordinate your body part exercise program and your personal schedule. If you select one exercise per body part you can normally do your entire routine in the same workout. If you choose to do more than 12 exercises you may decide to divide your workout routine into upper and lower body exercises. You can split your schedule to work upper body one day and lower body the next day. Remember to rest each particular muscle group 48 hours before working it again.

FOURTH:

Order the exercises in your routine so you are working the large muscle groups first and the small muscle groups last.

FIFTH:

Keep a record! Write down the exercises, number of sets, number of reps and the amount of resistance (weight).

BEGINNER'S SAMPLE WORKOUT ROUTINE WHEN TRAINING FOR DEFINITION

Exercise	Reps	Sets
Bench / Chest Press	15 to 20	3 or 4
Lat Pulldown	15 to 20	3 or 4
Shoulder Press	15 to 20	3 or 4
Tricep Pressdown	15 to 20	3 or 4
Bicep Curl	15 to 20	3 or 4
Leg Press/Squat	15 to 20	3 or 4
Leg Extension	15 to 20	3 or 4
Leg Curl	15 to 20	3 or 4
Calf Raise	15 to 20	3 or 4
Ab Crunch	20 to 30	3 or 4

Rest period between sets should be about 30 seconds.

Body-Solid

EXERCISE TIPS

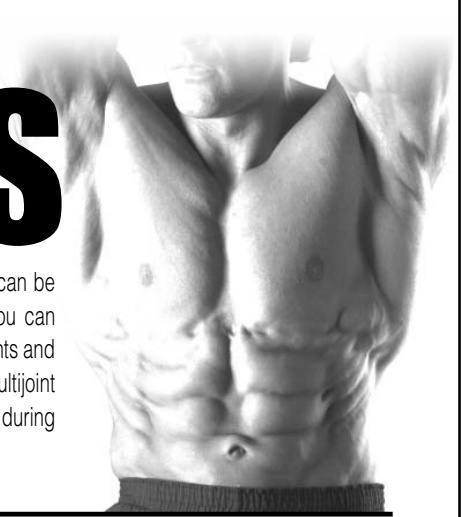

Listed below are Body-Solid's picks of the best exercises you can do for each body part. These exercises can be done using free weights, machines and multi-station gyms. Learn to do each exercise in proper form. You can make substitutions in your training and try variations of each using different Body-Solid grips, cable attachments and accessories to slightly change the emphasis of a particular exercise. Note: Many movements, especially multijoint exercises, work more than one muscle group. For example, your front deltoids and triceps are stimulated during bench / chest pressing movements.

CHEST

This powerful muscle group is the cornerstone of a well-developed upper body. To most thoroughly work your pecs, include both pressing and fly movements and vary the angle of the bench from decline to flat to incline.

BENCH / CHEST PRESS
INCLINE PRESS
DECLINE PRESS
PEC FLY
INCLINE FLY
DECLINE FLY
CABLE CROSSOVER
DIPS

SHOULDERS

The shoulder joint, which has the greatest range of motion of all joints in the body, is best worked by training all three deltoid heads. Include a pressing movement followed by a raise for each of the three heads.

SHOULDER PRESS
BEHIND THE NECK PRESS
FRONT DELTOID RAISE
LATERAL (SIDE) DELTOID RAISE
BENT-OVER LATERAL DELTOID RAISE
REVERSE PEC-FLY

UPPER BACK

A powerful upper back is marked by both middle-back thickness and width (the sought-after V-taper). This is best achieved by combining various rows with pull-downs and pull-ups. Remember to vary your grip to slightly change the stimulus.

PULL UP
UPRIGHT ROW
LAT PULLDOWN
SEATED ROW
BENT OVER ROW
HIGH ROW
REVERSE GRIP PULLDOWN

TRAPS

A signature muscle of a strong upper back, well-developed traps help prevent neck injury. Shrug movements should be done with heavy weights in a straight up-and-down motion.

STRAIGHT BAR SHRUG
DUMBBELL SHRUG
BEHIND THE BACK SHRUG
UPRIGHT ROW

LOWER BACK

Important not only for spinal protection but also because it's the seat of power for many exercises. If you spend a great deal of time crunching for abs, you need to balance your training for complete development and muscular balance.

PULL UP
UPRIGHT ROW
LAT PULLDOWN
SEATED ROW
BENT OVER ROW
HIGH ROW
REVERSE GRIP PULLDOWN

TRICEPS

This three-headed muscle on the back of your arm is involved in extension of the elbow. Like the biceps, the triceps cross the elbow and shoulder joints. Because of this, you can and should work the triceps through a variety of angles to ensure complete development.

LYING TRICEPS EXTENSION
CABLE TRICEPS EXTENSION
CABLE TRICEPS PRESSDOWN
CLOSE-GRIP BENCH PRESS
REVERSE-GRIP PRESSDOWN
TRICEPS PRESS
DIPS

BICEPS / FOREARMS

A two-headed muscle, the biceps' primary focus is to flex your elbow and supinate your wrist. The ability to build your biceps peak is largely genetic, but exercises that maximally stress the short head will help.

BICEPS
STANDING BICEP CURL
SEATED BICEP CURL
INCLINE CURL
PREACHER CURL
CONCENTRATION CURL
ONE-ARM CABLE CURL
FOREARMS
WRIST CURL
REVERSE WRIST CURL

ABDOMINALS

The rectus abdominus has upper and lower regions, but you can't isolate one area over the other. Still, include both upper and lower ab movement to more strongly emphasize those areas, and do twisting movements to work the obliques for complete development.

UPPER AB REGION
CABLE AB CRUNCH
DECLINE BENCH CRUNCH
LOWER AB REGION
REVERSE CRUNCH
HANGING KNEE RAISE
HIP THRUST
OBLIQUES
CABLE SIDE BEND
OBLIQUE CRUNCH

THIGHS / GLUTES

The main muscles of the thighs are the quadriceps which are composed of four muscles. You have several others near the hip joint, including the body's largest muscle group, the gluteal. Multijoint movements (in which action occurs at both the hip and knee joints) are your best choice to work these muscles.

BACK SQUAT
FRONT SQUAT
LEG PRESS
LUNGE
REVERSE LUNGE
STEP-UP
LEG EXTENSION (does not work glutes)

HAMSTRINGS

On the back of the thighs, the hamstrings balance the quads and allow for a wide range of movement. Good exercise choices include those that work the hamstrings and both the hip and knee joints.

DEADLIFT
STIFF-LEGGED DEADLIFT
GOOD MORNING
LYING LEG CURL
SEATED LEG CURL
ONE-LEGGED STANDING LEG CURL

CALVES

Calves consist of two major muscles, the gastrocnemius and soleus. The latter is best worked when the knee is flexed, as in the seated calf raise.

STANDING CALF RAISE
SEATED CALF RAISE
DONKEY CALF RAISE
LEG PRESS CALF RAISE
HACK SQUAT CALF RAISE

Body-Solid

ANATOMY CHART



FRONT VIEW

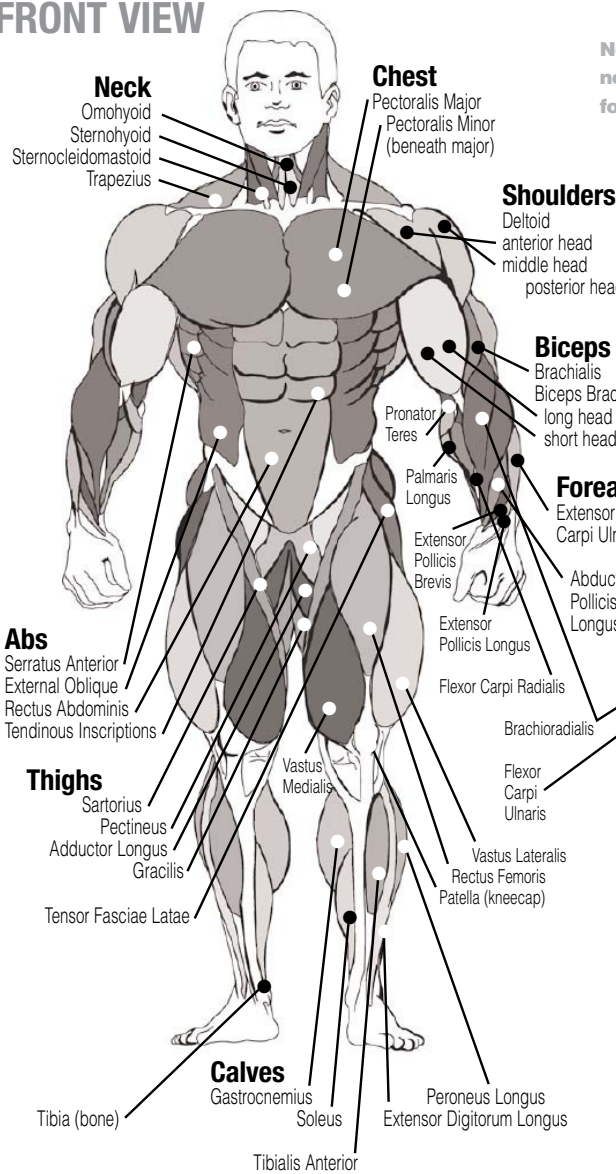

Note: These illustrations depicting exaggerated musculature are not in the textbook anatomical position. As such, they are inexact for medical purposes but are useful for a general understanding.

BACK VIEW

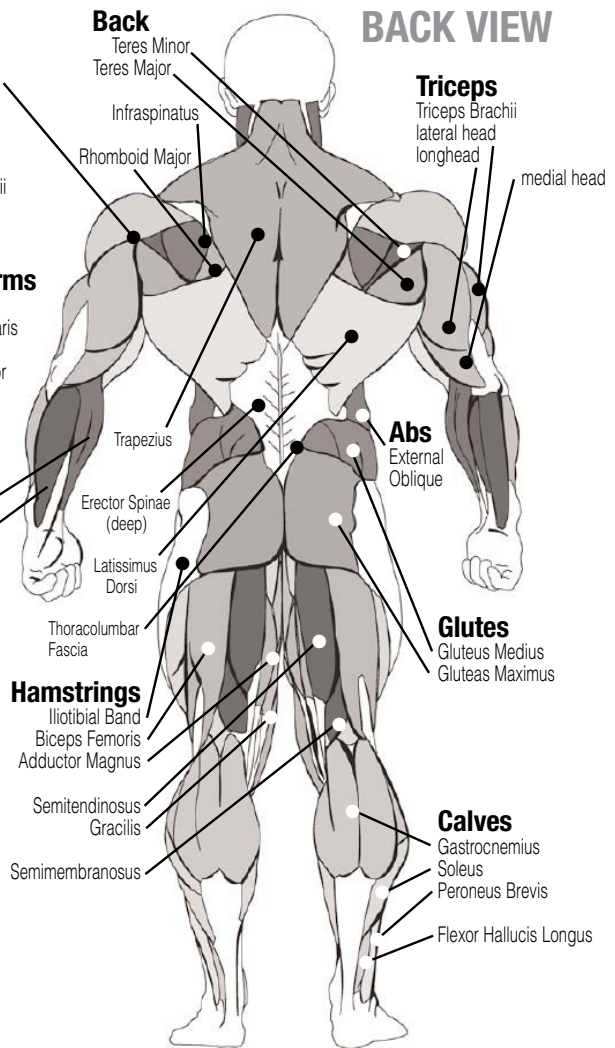



SHORT-TERM GOALS

Date Set _____ Date Accomplished _____

Goal _____

Reward** _____

Date Set _____ Date Accomplished _____

Goal _____

Reward** _____

Date Set _____ Date Accomplished _____

Goal _____

Reward** _____

LONG-TERM GOALS

Goal _____

Reward! _____

* Make several copies of this page to keep track of your goals and accomplishments.
You can print more copies of this page by going to <http://www.bodysolid.com/support/docs.html>
** Don't forget to reward yourself for a job well-done!

WEIGHT TRAINING EXERCISE LOG



BEGINNER'S SAMPLE WORKOUT ROUTINE																S = Sets R = Repetitions per set W = Weight used					
Date	S R W S				S R W S				S R W S				S R W S								
	S	R	W	S	S	R	W	S	S	R	W	S	S	R	W	S					
Exercise																					
BENCH / CHEST PRESS																					
LAT PULLDOWN																					
SHOULDER PRESS																					
TRICEP PRESSDOWN																					
BICEP CURL																					
LEG PRESS / SQUAT																					
LEG EXTENSION																					
LEG CURL																					
CALF RAISE																					
AB CRUNCH																					
TOTALS																					

* Make several copies of this page to keep track of your progress. You can print more copies of this page by going to <http://www.body-solid.com/support/docs.html>



WEIGHT TRAINING EXERCISE LOG

Date	S			R			W		
	S	R	W	S	R	W	S	R	W
Exercise									
LEG PRESS / SQUAT									
LEG EXTENSION									
LEG CURL									
CALF RAISE									
BENCH / CHEST PRESS									
INCLINE PRESS									
INCLINE PEC FLY									
LAT PULLDOWN									
SEATED ROW									
MILITARY PRESS									
UPRIGHT ROW									
BICEP CURL									
TRICEP PRESSDOWN									
TRICEP EXTENSION									
RESISTANCE AB CRUNCH									
RESISTANCE OBLIQUE CRUNCH									
TOTALS									

S = Sets
R = Repetitions per set
W = Weight used

SAMPLE WORKOUT ROUTINE WHEN TRAINING FOR STRENGTH

Keep track of your changes and improvements. It's a great motivational tool!*

* Make several copies of this page to keep track of your progress. You can print more copies of this page by going to <http://www.bodysolid.com/support/docs.html>

WEIGHT TRAINING EXERCISE LOG



Date	S = Sets			R = Repetitions per set			W = Weight used		
	S	R	W	S	R	W	S	R	W
Exercise									
TOTALS									

* Make several copies of this page to keep track of your progress. You can print more copies of this page by going to <http://www.bodysolid.com/support/docs.html>

Body-Solid

STRETCHING & FLEXIBILITY



Flexibility is an important component of physical fitness and needs to be addressed in a resistance training program. The two main purposes for stretching are injury prevention and a faster rate of recovery from exercise. Stretching should be performed in both the warm up and cool down phases of a training session. A good general guideline is that each workout session should be preceded by 5 to 15 minutes of general warm up, followed by 8 to 12 minutes of stretching, and concluded with 4 to 5 minutes of post-exercise stretching.

A regular stretching program will loosen muscle tissue, allowing an increased range of motion. This helps prevent microtears at the muscle-tendon junction. Almost 90% of all injuries from muscle strain occur at the muscle-tendon junction. Repeated injury at this junction can lead to a build-up of scar tissue, which impedes range of motion and adds stress to the joints.

Begin by stretching the major muscle groups first. Move in and out of your stretches with smooth, slow, controlled motion. Hold the stretch for at least 10 seconds when you feel you have reached your muscle's maximum distance. Do not use fast, hurried or reckless motions when stretching. Fast and bouncy motions will increase the risk of injury.

The most common and most popular type of stretching is the **static stretching** technique. This form of stretching involves voluntary, complete relaxation of the muscles while they are elongated. A static stretch is a constant, steady stretch in which the end position is held for 10 to 30 seconds. This technique is popular because it is easy to learn, effective, and accompanied by minimal soreness with the least risk of injury.

Ballistic stretching involves a bouncing or bobbing movement during the stretch. The final position in the movement is not held. Ballistic stretching is unpopular because of the increased amount of delayed muscle soreness and the possibility of injury during the stretching exercise. Ballistic stretching is not recommended.

A dynamic stretch involves flexibility during sport specific movements. **Dynamic stretching** is similar to ballistic stretching in that it utilizes movement, but dynamic stretching includes movements that may be specific to a sport or movement pattern. Dynamic stretching is most common among track and field athletes, but is also used in other sports, such as basketball and volleyball. An example of dynamic stretching would be a track sprinter performing high knees with an emphasis on knee height and arm action, not on horizontal speed.

The following pages show illustrations with descriptions of static stretching for warm up and post-exercise cool down. Remember... stretch your large muscle groups first and do all stretches in a smooth, slow, controlled manner.

STRETCHING WARM-UP/COOL-DOWN



UPPER BACK

Cross Arm in Front of Chest

MUSCLE(S) AFFECTED: *latissimus dorsi* and *teres major*

1. Stand or sit with the right arm slightly flexed (15° to 30°) and adducted across the chest.
2. Grasp the upper arm just above the elbow, placing the left hand on the posterior side of the upper arm.
3. Pull the right arm across the chest (toward the left) with the left hand.
4. Hold for 10 seconds.
5. Repeat with the left arm.

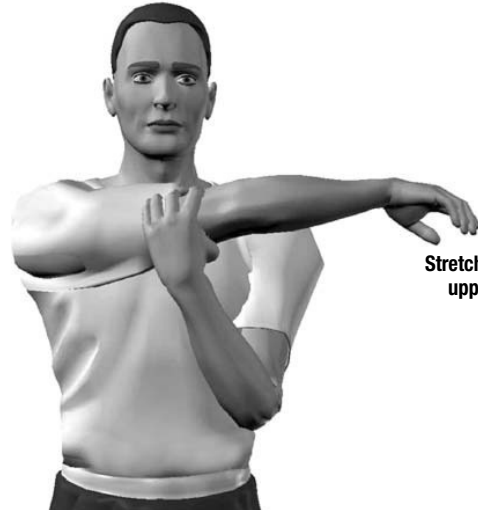

Stretching the upper back

UPPER BACK

Arms Straight Up Above Head (Pillar)

MUSCLE(S) AFFECTED: *latissimus dorsi* and *wrist flexors*

1. Stand with arms in front of torso, fingers interlocked with palms facing each other.
2. Slowly straighten the arms above the head with palms up.
3. Continue to reach upward with hands and arms.
4. While continuing to reach upward, slowly reach slightly backward.
5. Hold for 10 seconds.



Stretching the shoulders, chest and upper back

LOWER BACK

Spinal Twist (Pretzel)

MUSCLE(S) AFFECTED: *internal oblique*, *external oblique* and *spinal erectors*

1. Sitting with legs straight and upper body nearly vertical, place right foot on left side of left knee.
2. Place back of left elbow on right side of right knee, which is now bent.
3. Place right palm on floor 12 to 16 inches behind hips.
4. Push right knee to the left with left elbow while turning shoulders and head to the right as far as possible. Try to look behind the back.
5. Hold for 10 seconds.
6. Repeat with left leg.



Stretching the low back and sides

Body-Solid

STRETCHING WARM-UP/COOL-DOWN



LOWER BACK

Semi-Leg Straddle

MUSCLE(S) AFFECTED: *spinal erectors*

1. Sitting, knees flexed 30 to 50 degrees, let the legs totally relax.
2. Point the knees outward; the lateral side of the knees may or may not touch the floor.
3. Lean forward from waist and reach forward with extended arms. Hold position for 10 to 15 seconds.
4. Bending and relaxing legs decreases hamstring involvement and increases lower back stretch.



Stretching the low back from seated position

HIPS

Forward Lunge (Fencer)

MUSCLE(S) AFFECTED: *iliopsoas, rectus femoris*

1. Standing, take a long step forward (as with the lunge) with the right leg and flex the right knee until it is directly over the right foot.
2. Keep right foot flat on floor.
3. Keep back leg straight.
4. Keep back foot pointed in same direction as front foot; it is not necessary to have heel on floor.
5. Keep torso upright and rest hands on hips or front leg.
6. Slowly lower hips forward and downward.
7. Hold for 10 to 15 seconds.
8. Repeat with the left leg.



Stretching the hip flexors

HIPS

Supine Knee Flex

MUSCLE(S) AFFECTED: *hip extensors (gluteus maximus and hamstrings)*

1. Lie on back with legs straight.
2. Flex right leg and lift knee toward chest.
3. Place both hands below knee and continue to pull knee toward chest.
4. Hold for 10 to 15 seconds.
5. Repeat with left leg.



Stretching the gluteals and hamstrings

Body-Solid

STRETCHING WARM-UP/COOL-DOWN



SHOULDER

Seated Lean-Back

MUSCLE(S) AFFECTED: *deltoids and pectoralis major*

1. Sitting with legs straight and arms extended, place palms on floor about 12 inches behind hips.
2. Point fingers away (backward) from body.
3. Slide hands backward and lean backward.
4. Hold for 10 seconds.

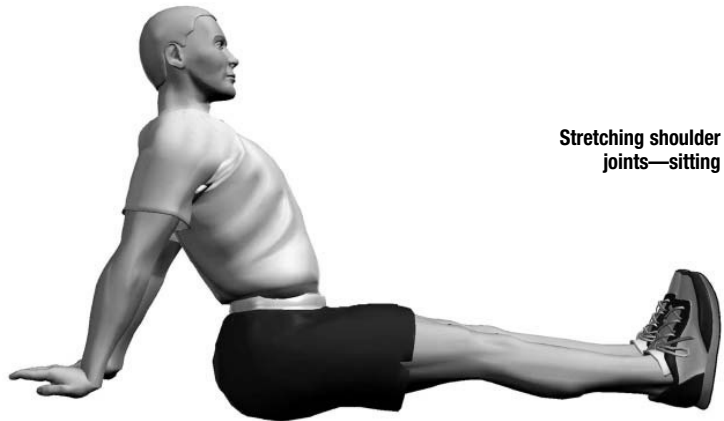

Stretching shoulder joints—sitting

CHEST

Straight Arms Behind Back

MUSCLE(S) AFFECTED: *deltoids and pectoralis major*

1. Standing, place both arms behind back.
2. Interlock fingers with palms facing each other.
3. Straighten arms fully.
4. Slowly raise the straight arms.
5. Hold for 10 to 15 seconds.
6. Keep head upright and neck relaxed.



Stretching the chest

POSTERIOR OF UPPER ARM

Behind-Neck Stretch (Chicken Wing)

MUSCLE(S) AFFECTED: *triceps and latissimus dorsi*

1. Standing or sitting, flex right arm and raise elbow above head.
2. Reach the right hand down toward the left scapula.
3. Grasp right elbow with left hand.
4. Pull elbow behind head with left hand.
5. Hold for 10 seconds.
6. Repeat with left arm.



Stretching the triceps



STRETCHING WARM-UP/COOL-DOWN

NECK

Look Right and Left

MUSCLE(S) AFFECTED: *sternocleidomastoid*

1. Stand or sit with head and neck upright.
2. Turn head to the right using a submaximal concentric contraction. Hold for 10 seconds.
3. Turn head to the left using a submaximal concentric contraction. Hold for 10 seconds.



Rotational flexion of the neck

NECK

Flexion and Extension

MUSCLE(S) AFFECTED: *sternocleidomastoid, suboccipitals and splenii*

1. Standing or sitting with head and neck upright, flex neck anteriorly (forward) by tucking chin in toward the chest; hold for 10 seconds.
2. If the chin touches the chest, try to touch lower on the chest with the chin.
3. Extend neck posteriorly (backward) by trying to touch the head to the trapezius; hold for 10 seconds.

Neck extension

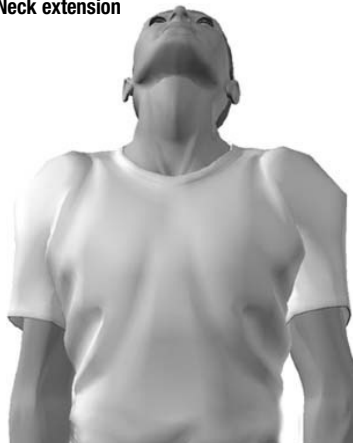

Neck flexion



SHOULDER

Straight Arms Behind Back

MUSCLE(S) AFFECTED: *deltoids and pectoralis major*

1. Standing, place both arms behind back.
2. Interlock fingers with palms facing each other.
3. Straighten arms fully.
4. Slowly raise the straight arms.
5. Hold for 10 to 15 seconds.
6. Keep head upright and neck relaxed.



Stretching shoulder joints—standing



Body-Solid

STRETCHING WARM-UP/COOL-DOWN

SIDES

Side Bend with Straight Arms

MUSCLE(S) AFFECTED: *external oblique, latissimus dorsi and serratus anterior*

1. Stand with feet 14 to 16 inches apart.
2. Interlace the fingers with palms facing each other.
3. Reach upward with straight arms.
4. Keeping arms straight, lean from waist to left side.
Do not bend knees.
5. After moving as far as possible, hold for 10 seconds.
6. Repeat to the left side.



Stretching the sides, upper back and shoulders

SIDES

Side Bend with Bent Arm

MUSCLE(S) AFFECTED: *external oblique, latissimus dorsi, serratus anterior and triceps*

1. Stand with feet 14 to 16 inches apart.
2. Flex right arm and raise elbow above head.
3. Reach the right hand down toward the left shoulder.
4. Grasp the right elbow (just above the elbow) with the left hand.
5. Pull the elbow behind head.
6. Keeping arm bent, lean from waist to left side.
7. Do not bend knees.
8. After moving as far as possible, hold for 10 to 15 seconds.
9. Repeat with the left arm.



Stretching the sides, triceps and upper back

ANTERIOR OF THIGH AND HIP FLEXOR

Side Quadriceps Stretch

MUSCLE(S) AFFECTED: *quadriceps and iliopsoas*

1. Lie on left side with both legs straight.
2. Place left forearm flat on floor and upper arm perpendicular to floor.
3. Place left forearm at 45° angle with torso.
4. Flex right leg with heel of right foot moving toward buttocks.
5. Grasp front of ankle with right hand and pull toward buttocks.
WARNING: Do not pull on ankle so hard that pain or discomfort is felt in knee.
6. Move knee backward and slightly upward. The stretch occurs not so much from the excessive flexion of the knee but from moving the knee back and slightly up.
7. Hold for 10 to 15 seconds.
8. Repeat with the left leg.



Stretching the quadriceps on side

STRETCHING WARM-UP/COOL-DOWN



ANTERIOR OF THIGH AND HIP FLEXOR

Kneeling Quadriceps Stretch

MUSCLE(S) AFFECTED: *quadriceps*

1. Kneel with the balls of the feet on the ground.
2. Keep hips straight (upper leg and torso should be in a straight line).
3. Place palms of hands on buttocks and push slightly forward.
4. With a straight body, lean slightly backward until developmental stretch is felt in quadriceps.
5. Hold for 10 to 15 seconds.



Stretching the quadriceps kneeling

POSTERIOR OF THIGH

Sitting Toe Touch

MUSCLE(S) AFFECTED: *hamstrings, spinal erectors and gastrocnemius*

1. Sit with the upper body nearly vertical and legs straight.
2. Lean forward from waist and grasp toes with each hand, slightly pull toes towards the upper body, and pull chest towards leg. (If you are very stiff, try to grasp the ankles.) Hold for 10 seconds.
3. Release toes and relax foot.
4. Grasp ankles and continue to pull chest towards legs. Hold for 10 seconds.
5. Still grasping the ankles, point away from body and continue to pull chest towards legs. Hold for 10 seconds.

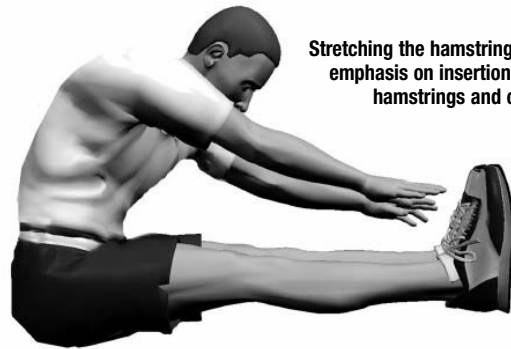

Stretching the hamstrings with emphasis on insertion of the hamstrings and calves.



Stretching the hamstrings with emphasis on the middle portion.



Stretching the hamstrings with emphasis on the upper portion.



POSTERIOR OF THIGH

Semistraddle (Figure Four)

MUSCLE(S) AFFECTED: *gastrocnemius, hamstrings and spinal erectors*

1. Sit with the upper body nearly vertical and legs straight.
2. Place sole of left foot on left side of right knee. The lateral side of left leg should be resting on the floor.
3. Lean forward from the waist and grasp toes with right hand and slightly pull toes toward the upper body as the chest is also pulled toward right leg. Hold for 10 seconds.
4. Release toes and relax foot.
5. Grasp ankle and continue to pull chest toward right leg. Hold for 10 seconds.
6. Point toes away from body and continue to pull chest toward right leg. Hold for 10 seconds.
7. Repeat with the left leg.



Stretching the hamstrings with emphasis on insertion of the hamstrings and calves



Stretching the hamstrings with emphasis on the middle portion



Stretching the hamstrings with emphasis on the upper portion

Remember... do all stretches in a smooth, slow, controlled manner.

STRETCHING WARM-UP/COOL-DOWN



GROIN

Straddle (Spread Eagle)

MUSCLE(S) AFFECTED: *gastrocnemius, hamstrings, spinal erectors, adductors and sartorius*

1. Sit with the upper body nearly vertical and legs straight, and spread legs as far as possible.
2. With right hand, grasp toes of right foot and pull on toes slightly, while pulling chest toward right leg. Hold for 10 seconds.
3. Release toes and relax foot.
4. Grasp ankle and continue to pull chest toward right leg. Hold for 10 seconds.
5. Point toes away from body and continue to pull chest toward right leg. Hold for 10 seconds.
6. Repeat process with the left leg.
7. Repeat process by grasping right toes with right hand and left toes with left hand. Move the torso forward and toward the ground.

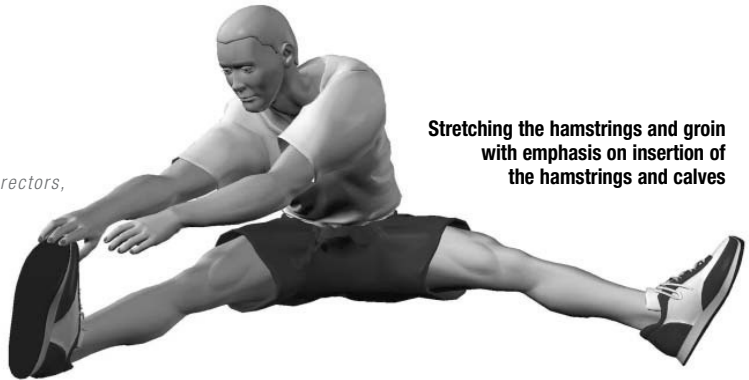

Stretching the hamstrings and groin with emphasis on insertion of the hamstrings and calves



Stretching the hamstrings and groin with emphasis on the middle portion

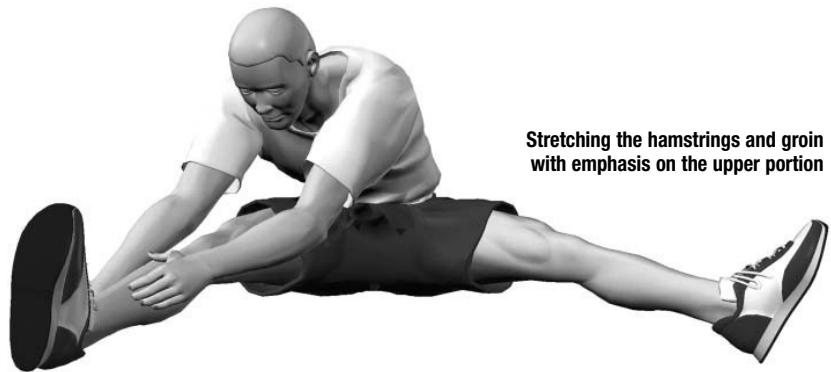

Stretching the hamstrings and groin with emphasis on the upper portion



Stretching the groin, low back and hamstrings

Body-Solid

STRETCHING WARM-UP/COOL-DOWN



GROIN

Butterfly

MUSCLE(S) AFFECTED: *adductors and sartorius*

1. Sitting with the upper body nearly vertical and legs straight, flex both knees as the soles of the feet come together.
2. Pull feet toward body.
3. Place hands on feet and elbows on legs.
4. Pull torso slightly forward as elbows push legs down.
5. Hold for 10 to 15 seconds.



Stretching the groin

POSTERIOR OF LOWER LEG

Bent-Over Toe Raise

MUSCLE(S) AFFECTED: *gastrocnemius and soleus*

1. Stand with heel of right foot 6 to 8 inches in front of left foot.
2. Flex right foot toward shin (dorsi-flexion) with heel in contact with floor.
3. Lean forward and try to touch right leg with chest while both legs are straight.
4. Continue to lean downward with upper body as the foot is dorsi-flexed near maximal toward the shin.
5. Hold for 10 to 15 seconds.
6. Repeat with the left leg.



Stretching calves without a step

STRETCHING WARM-UP/COOL-DOWN



POSTERIOR OF LOWER LEG

Step Stretch

MUSCLE(S) AFFECTED: *gastrocnemius and soleus; also, achilles tendon*

1. Have ready a step or board 3 to 4 inches high.
2. Place balls of both feet on the step or board, 1 inch from its edge.
3. With straight legs, lower heels as far as possible.
4. Hold for 10 to 15 seconds.
5. To stretch achilles tendon, raise heels slightly. Slightly flex the knees and then lower the heels. This stretch will be felt in the achilles tendon.
6. Hold for 10 to 15 seconds.
7. For a more intense and individualized stretch, perform this stretch with one leg at a time.



Stretching the calves standing on a step



Preparing to stretch the achilles tendon by slightly bending the knee



Stretching the achilles tendon by lowering the heel

Mainframe Parts List

PART#	QTY	DESCRIPTION
A	1	MAIN BASE FRAME
B	1	REAR UPRIGHT FRAME
C	1	MAIN TOP FRAME
D	1	PULLEY HOLDER WITH STOP
E	1	REAR LEG
F	1	SEATED PRESS ARM
G	2	CHROME GUIDE ROD
H	4	CONTOURED BACKING PLATE 170L
I	1	ROLLER BAR (1"X535L)
J	1	ROLLER BAR (1"X500L)
K	1	PRESS ARM SUPPORT
L	1	PIVOTING BACK REST FRAME
N	1	MAIN FRONT FRAME
O	1	BACK PAD ADJUSTER
P	1	HOLDER FOR DOUBLE PARALLEL PULLEYS
Q	1	ADJUSTABLE SEAT FRAME
R	2	PULLEY HOLDER
S	1	LEG HOLD DOWN FRAME
T	1	FUNCTIONAL TRAINING ARMS PIVOT BASE
U	1	HOLDER FOR DOUBLE CROSSED PULLEYS
V	1	SIDE LEG HOLD DOWN FRAME
W	1	FUNCTIONAL TRAINING ARM (left side)
X	1	FUNCTIONAL TRAINING ARM (right side)
Y	2	END PULLEY HOLDER
Z	1	LEG EXTENSION ARM
AA	1	FUNCTIONAL TRAINING ARMS REAR PULLEY SUPPORT
AB	1	FRONT SHROUD
AC	1	BACK SHROUD
AD	1	PRESS ARM STOP
AE	1	LAT PULL DOWN BAR HOLDER (left side)
AF	1	LAT PULL DOWN BAR HOLDER (right side)
AG	1	LEFT ARM REST
AH	1	RIGHT ARM REST
AI	1	PIVOT BUSHING
AJ	1	ASSISTANT SUPPORT

Part numbers are required when ordering parts.

Hardware List

PART#	QTY	DESCRIPTION
1	3	ACORN CAP NUT M6-preinstalled
2	3	ALLEN HEAD BOLT M10 X 115L PARTIAL THREAD
3	4	ALLEN HEAD BOLT M10 X 125L PARTIAL THREAD
4	4	ALLEN HEAD BOLT M10 X 10L FULL THREAD - preinstalled
5	7	ALLEN HEAD BOLT M10 X 15L FULL THREAD - preinstalled
6	20	WEIGHT PLATES
7	1	WEIGHT STACK LANYARD
8	1	WEIGHT STACK PIN 10 X 138L
9	2	WEIGHT STACK SHIM 50 X 50
10	5	ALLEN HEAD BOLT M8 X 10L FULL THREAD - preinstalled
11	2	ALLEN HEAD BOLT M8 X 15L FULL THREAD - preinstalled
12	1	ALLEN SCREW M4 X 8L FULL THREAD
14	8	ALLEN SCREW M5 X 5L FULL THREAD - preinstalled
15	6	ALLEN SCREW M8 X 6L FULL THREAD - preinstalled
16	2	ALLEN SCREW M8 X 8L FULL THREAD - preinstalled
19	2	BUSHING 37 ID X 50 OD - preinstalled
20	2	BEARING 12 ID X 32 OD - preinstalled
21	2	BEARING 20 ID X 42 OD - preinstalled
22	2	BEARING 30 ID X 38 OD - preinstalled
23	1	CABLE END SHAFT
24	2	CHROME COLLAR 26 ID X 35 OD - preinstalled
25	2	TAPERED CROSSHEAD SCREW M5 X 10L FULL THREAD- preinstalled
26	4	CONVEX END CAP 1" X 2"
27	2	CONVEX END CAP 30 X 70
28	5	CONVEX END CAP 40 X 80
29	2	CONVEX END CAP 50 X 100
30	1	CONVEX END CAP 50 X 50
31	5	CROSSHEAD SCREW M4 X 6L FULL THREAD - preinstalled
32	2	FLAT END CAP 30 X 60
33	2	CHROME COLLAR 26 ID X 38 OD - preinstalled
34	1	FLAT END CAP 40 X 40
35	2	FLAT END CAP 45 X 45
36	1	FLAT HEAD POP PIN 124L - preinstalled
37	1	FLAT HEAD POP PIN 124L (back pad angle adjuster) - preinstalled
38	1	FLAT HEAD POP PIN 138L - preinstalled
39	1	FLAT HEAD POP PIN 96L (back pad position adjuster) - preinstalled
40	2	FOAM GRIP 38 OD X 545L (seated press) - preinstalled
41	6	FOAM ROLLER 4" X 8"
42	2	FOOT CAP 50 X 100
43	1	FUNCTIONAL TRAINING COVER
44	1	HEX HEAD BOLT M10 X 110L PARTIAL THREAD
45	2	HEX HEAD BOLT M10 X 85L PARTIAL THREAD
46	1	HEX HEAD BOLT M10 X 60L PARTIAL THREAD
47	16	HEX HEAD BOLT M10 X 45L PARTIAL THREAD
48	2	HEX HEAD BOLT M10 X 55L PARTIAL THREAD
49	5	HEX HEAD BOLT M10 X 70L PARTIAL THREAD

Part numbers are required when ordering parts.

Hardware List (continued)

PART#	QTY	DESCRIPTION
50	12	HEX HEAD BOLT M10 X 75L PARTIAL THREAD
51	1	HEX HEAD BOLT M10 X 65L PARTIAL THREAD - preinstalled
52	2	HEX HEAD BOLT M8 X 50L PARTIAL THREAD
53	2	HEX HEAD BOLT M8 X 55L PARTIAL THREAD
54	1	HYDRAULIC SEAT ADJUSTER-preinstalled
55	1	JAM NUT 1/2" - preinstalled
56	2	JAM NUT 3/8" - preinstalled
57	2	JAM NUT M10
58	2	NYLON BUSHING 40 X 80
59	1	NYLON BUSHING 60 X 45
60	48	NYLON LOCK NUT M10
61	4	BEARING 15 ID X 32 OD - preinstalled
62	12	NYLON WASHER 3"
63	2	OILITE BUSHING 1"ID X 45 OD - preinstalled
64	2	OILITE BUSHING 1/2" ID X 21 OD - preinstalled
65	1	NAME PLATE
66	1	NAME PLATE SEAT
67	4	PULLEY SPACER 16 X 12L
68	4	PULLEY SPACER 16 X 21.5L
69	6	PULLEY SPACER 16 X 42L
70	1	PULLEY 110
71	25	PULLEY 110
72	2	PULLEY 90
73	6	ROLLER END CAP
74	4	ROUND END CAP 1"
75	2	RUBBER DONUT 63.5
76	3	RUBBER PAD 38 X 38
77	2	RUBBER STOP 58.5L (3/8" bolt) - preinstalled
78	1	SELECTOR ROD (20 selector holes)
79	1	SELECTOR ROD TOP BOLT - preinstalled
80	1	SHAFT 1" X 196L - preinstalled
81	2	SHAFT COLLAR
82	1	SHAFT 12 X 122L - preinstalled
83	1	SHAFT 20 X 138L - preinstalled
84	2	RUBBER PAD 95 X 140
85	2	FOAM GRIP 34 OD X 340L - preinstalled
86	4	SNAP LINK
87	1	SOCKET HEAD BOLT 3/8" X2" PARTIAL THREAD
88	1	SOCKET HEAD BOLT M8 X 10L FULL THREAD - preinstalled
89	2	SPACER SLEEVE 16 X 39L
90	1	SPRING LOCK WASHER 1/2" - preinstalled
91	1	SPRING LOCK WASHER 3/8"
92	4	SPRING LOCK WASHER M8
93	1	HEX HEAD BOLT M10 X 25L FULL THREAD
94	2	SPRING LOCK WASHER M4 - preinstalled
95	1	TOP PLATE 10lbs
96	2	NYLON LOCK NUT M12 - preinstalled
97	1	TORSIONAL SPRING (left) - preinstalled
98	1	TORSIONAL SPRING (right) - preinstalled

Part numbers are required when ordering parts.

Hardware List (continued)

PART#	QTY	DESCRIPTION
99	1	T-SHAPED POP PIN - preinstalled
100	4	WASHER M10 X 19
101	90	WASHER M10 X 27
102	2	WASHER M12 X Ø34 - preinstalled
103	11	WASHER M8 X 18
104	1	HEX HEAD BOLT M10 X 50L PARTIAL THREAD
118	2	PLASTIC CLIPS 35 X 45
121	1	CHROME PLATE - preinstalled
122	1	ALLEN HEAD BOLT M10 X 60L PARTIAL THREAD
123	1	FOOT CAP 50X50
124	1	FRICON-PROOF RUBBER 70X95
125	2	RUBBER PAD 35X59 - preinstalled
130	2	STEEL CASING Ø15.9 ODX12L

Part numbers are required when ordering parts.

P a d s L i s t

PART#	QTY	DESCRIPTION
BA	1	SEAT PAD
BB	1	BACK PAD

C a b l e L i s t

PART#	QTY	DESCRIPTION
105	1	FUNCTIONAL TRAINING ARM CABLE 3028mm
106	1	LAT PULLDOWN CABLE 5425mm
107	1	LEG EXTENSION CABLE 3540mm
108	1	LEFT ATTACHMENT CABLE 1765mm
109	1	SHORT CABLE 775mm
110	2	TURNPLATE CABLE 530mm
120	1	RIGHT ATTACHMENT CABLE 3475mm

A c c e s s o r y L i s t

PART#	QTY	DESCRIPTION
111	2	ARTICULATING FUNCTIONAL TRAINING HARNESS
112	2	FOAM GRIP 1 1/2" OD X 8 1/2"L (low row bar)
113	2	FOAM GRIP 34 OD X 540L (lat bar)
114	1	LAT BAR
115	1	LAT BAR PAD
116	1	LOW ROW BAR
117	1	LEG HARNESS

Part numbers are required when ordering parts.

Hardware

(Actual Size Shown)

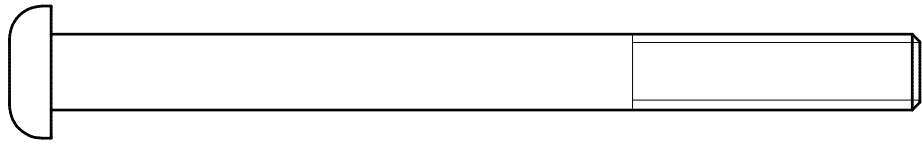
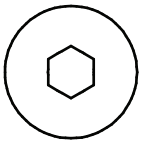

PART # 02 ALLEN HEAD BOLT M10X115L PARTIAL THRERD QTY.3

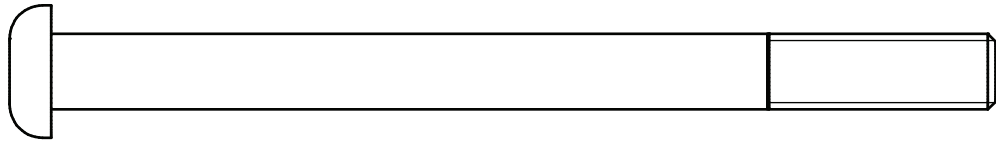
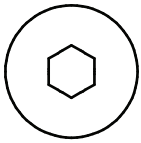

PART # 03 ALLEN HEAD BOLT M10X125L PARTIAL THRERD QTY.4

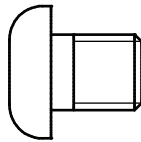
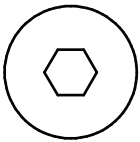

PART # 04 ALLEN HEAD BOLT M10X10L FULL THRERD QTY.4

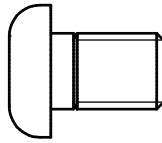
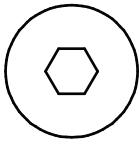

PART # 05 ALLEN HEAD BOLT M10X15L FULL THRERD QTY.7

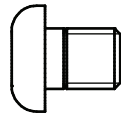
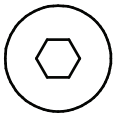

PART # 10 ALLEN HEAD BOLT M8X10L FULL THRERD QTY.5

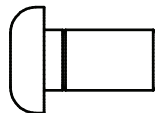
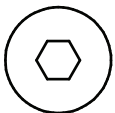

PART # 11 ALLEN HEAD BOLT M8X15L FULL THRERD QTY.2

Hardware

(Actual Size Shown)

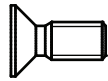

PART # 25 TAPERED CROSSHEAD SCREW M5X10L FULL THREAD QTY.2



PART # 31 CROSSHEAD SCREW M4X6L FULL THREAD QTY.5

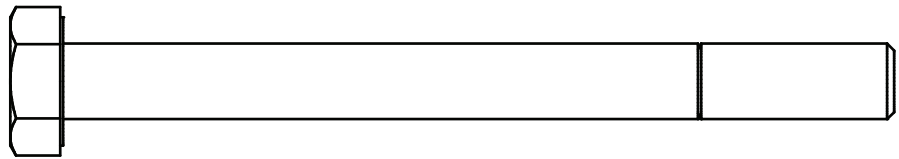
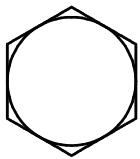

PART # 44 HEX HEAD BOLT M10X110L PARTIAL THREAD QTY.1

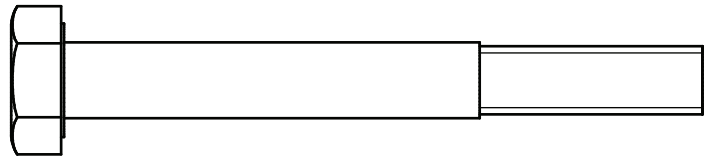
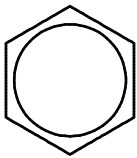

PART # 45 HEX HEAD BOLT M10X85L PARTIAL THREAD QTY.2

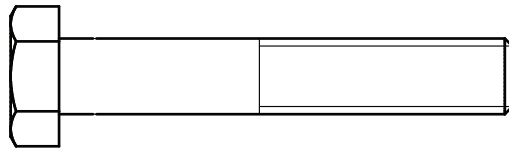
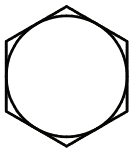

PART # 46 HEX HEAD BOLT M10X60L PARTIAL THREAD QTY.1

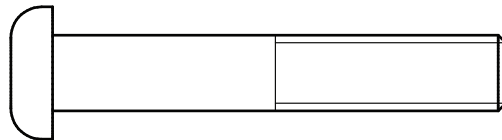
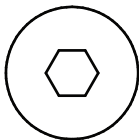

PART # 122 ALLEN HEAD BOLT M10X60L PARTIAL THREAD QTY.1

Hardware

(Actual Size Shown)

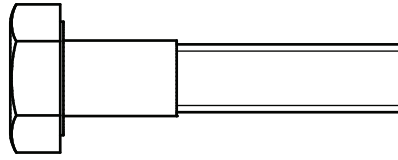
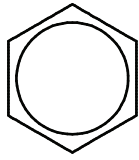

PART # 47 HEX HEAD BOLT M10X45L PARTIAL THREAD QTY.14

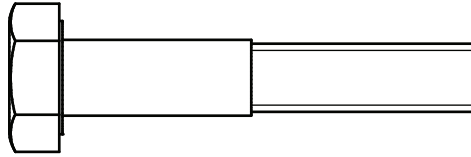
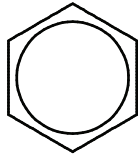

PART # 48 HEX HEAD BOLT M10X55L PARTIAL THREAD QTY.2

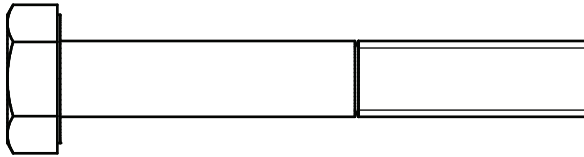
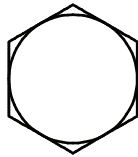

PART # 49 HEX HEAD BOLT M10X70L PARTIAL THREAD QTY.5

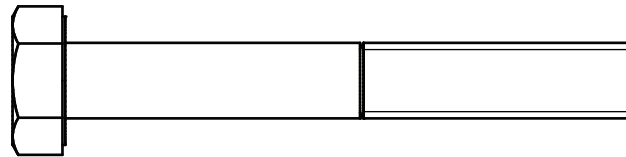
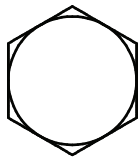

PART # 50 HEX HEAD BOLT M10X75L PARTIAL THREAD QTY.10

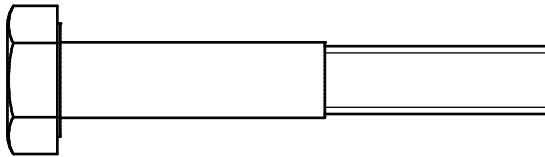
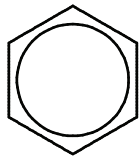

PART # 51 HEX HEAD BOLT M10X65L PARTIAL THREAD QTY.1

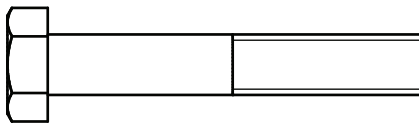
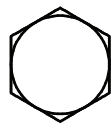

PART # 52 HEX HEAD BOLT M8X50L PARTIAL THREAD QTY.2

Hardware

(Actual Size Shown)

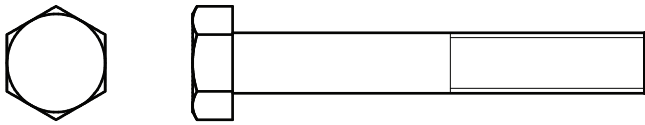

PART # 53 HEX HEAD BOLT M8X55L PARTIAL THREAD QTY.2

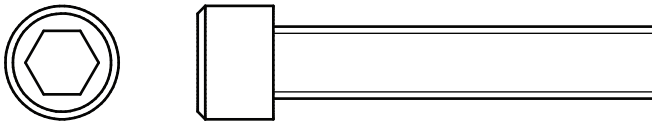

PART # 87 ROUND ALLEN HEAD BOLT 3/8"X2"L FULL THREAD QTY.1

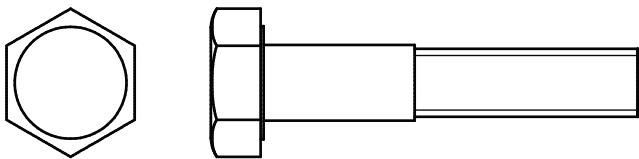

PART # 104 HEX HEAD BOLT M10X50L PARTIAL THREAD QTY.1

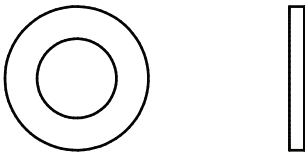

PART # 100 WASHER M10 X Ø19 QTY.4

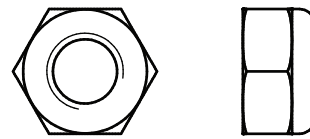

PART # 60 NYLON LOCK NUT M10 QTY.48

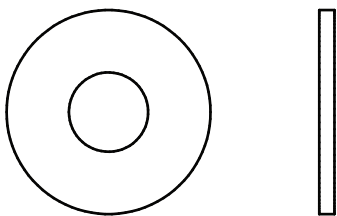

PART # 101 WASHER M10 X Ø27 QTY.90

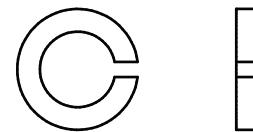

PART # 91 SPRING WASHER 3/8" QTY.1

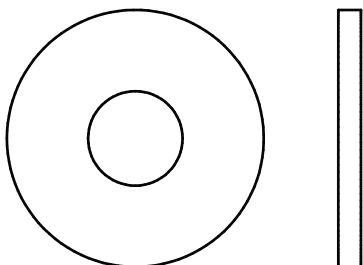

PART # 102 WASHER M12XØ34 QTY.2



PART # 92 SPRING WASHER M8 QTY.4

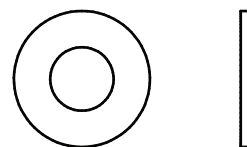

PART # 103 WASHER M8 QTY.4

Fusion 500

Exploded View

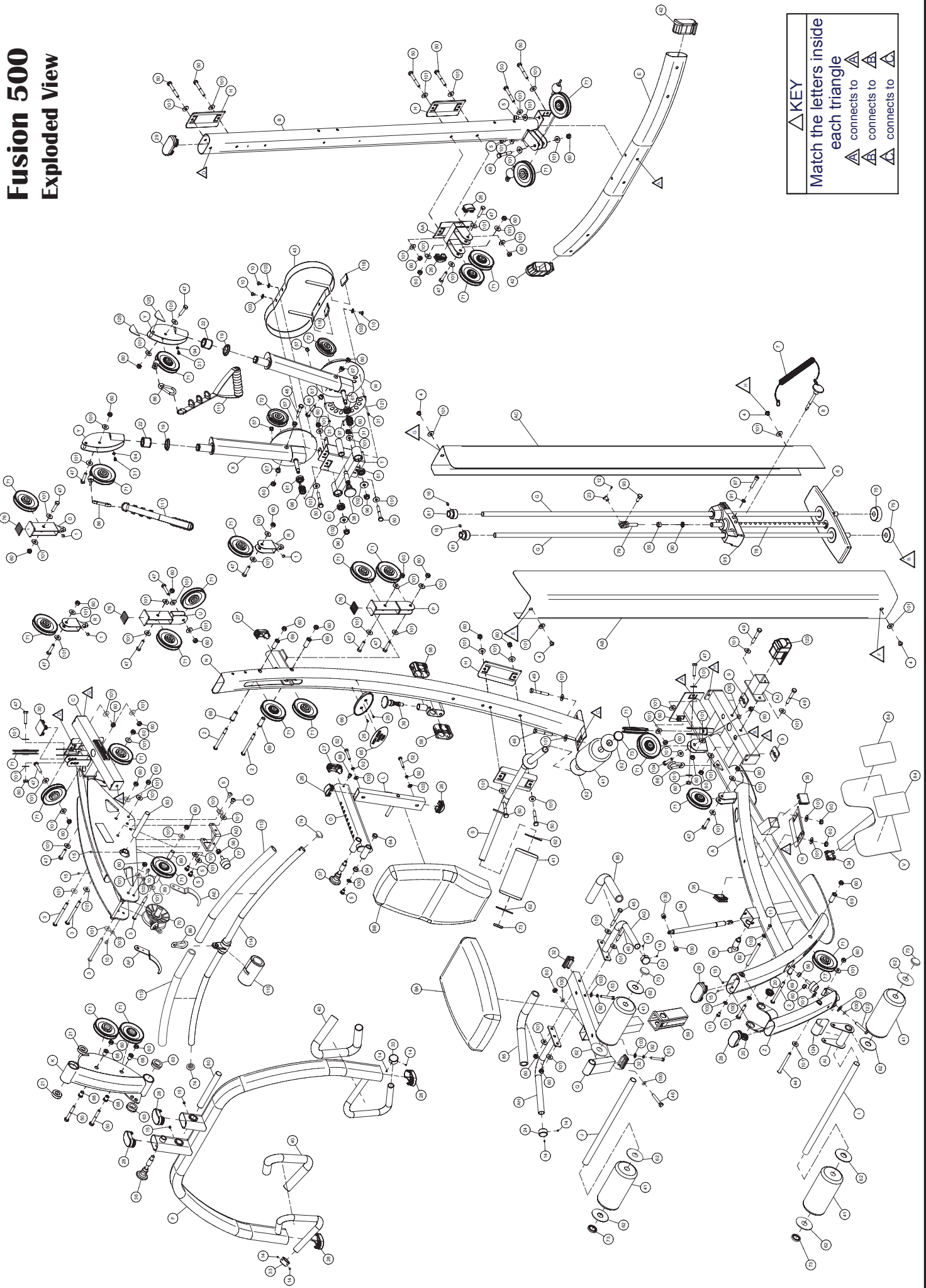

△ KEY
 Match the letters inside
 each triangle
 △ connects to △
 △ connects to △
 △ connects to △

Notes

Body-Solid[®]
Built for Life

1900 S. Des Plaines Ave.
Forest Park, IL 60130
1 (800) 556-3113
Hours: M-F 8:30 - 5:00

www.bodysolid.com