

Body-Solid®

Built for Life

GDIP-59

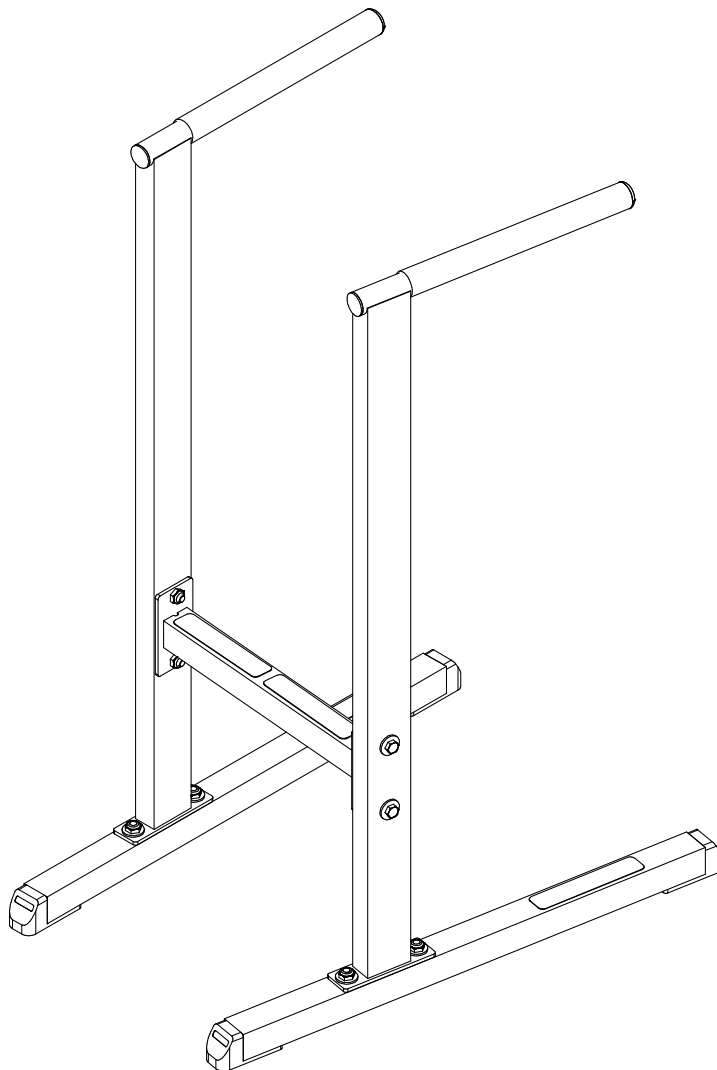

Table of Contents

Dimensions.....	p. 2
Reference Drawings.....	p. 3
Important Safety Instructions.....	p. 4
Before You Begin.....	p. 5
Preparations.....	p. 6
Assembly Instructions.....	p. 7-9
Mainframe Parts List.....	p. 10
Hardware List.....	p. 11
Hardware (To Scale).....	p. 12
Exploded View Diagram.....	p. 13

Assembly Instructions

OWNER'S & MANUAL

Dimensions

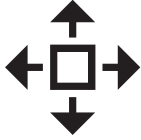

The room layout diagram below will help you decide the best placement for your GDIP-59.

The overall space needed for operation may be more depending on the user.

Minimum Usage Space – 2' 2" W x 3' 2" L x 4' 4" H

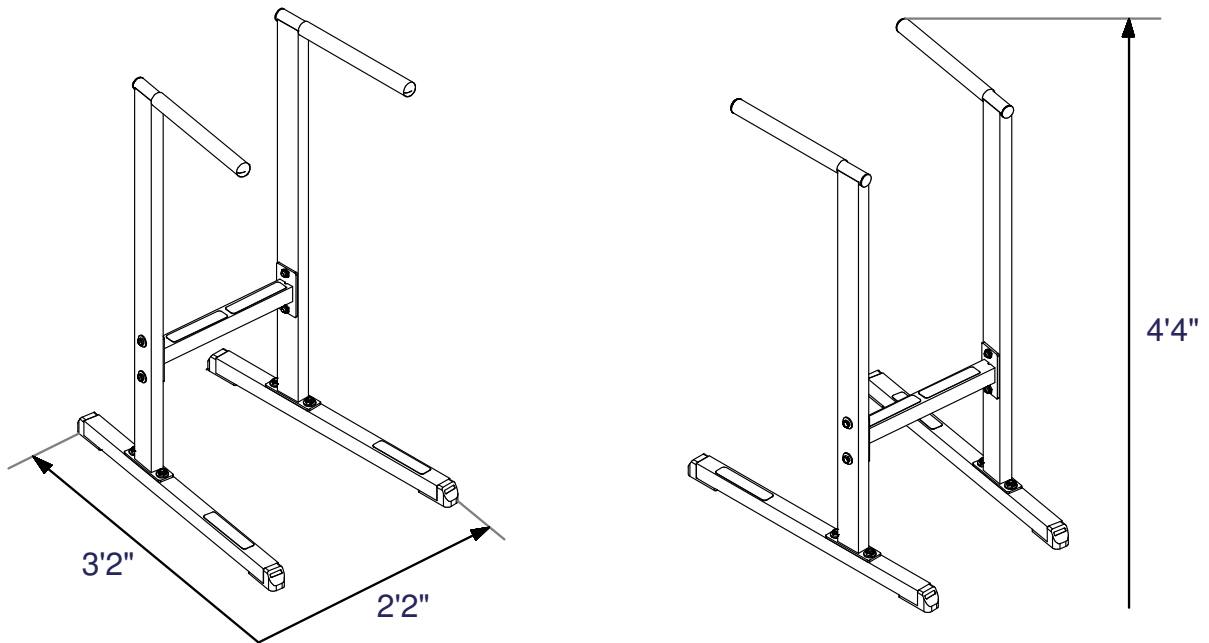

Suggested Usage Space – 5' 5" W x 6' 5" L

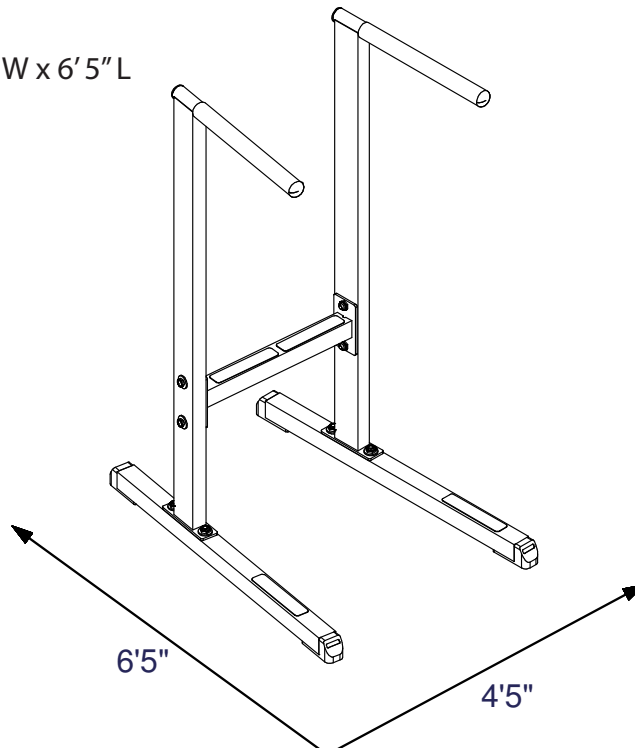

Reference Diagrams



Use the following diagrams as a point of reference when assembling your GDIP-59.

Becoming familiar with the unit and the orientation of its components will help ease installation. Please use the following diagrams to become more accustomed with your GDIP-59 and its applications.

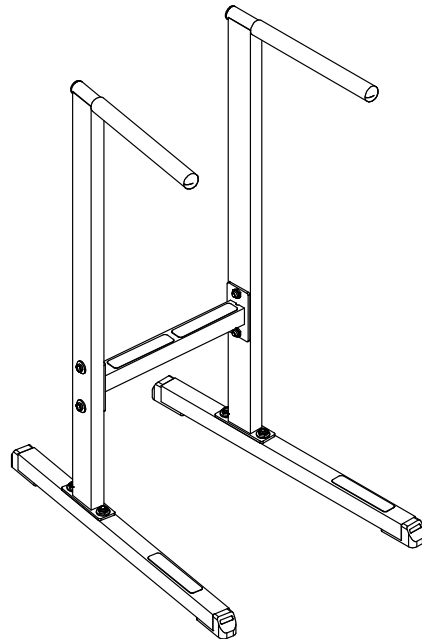
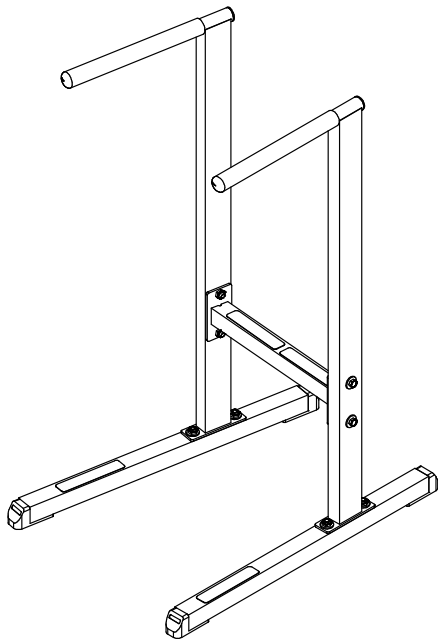
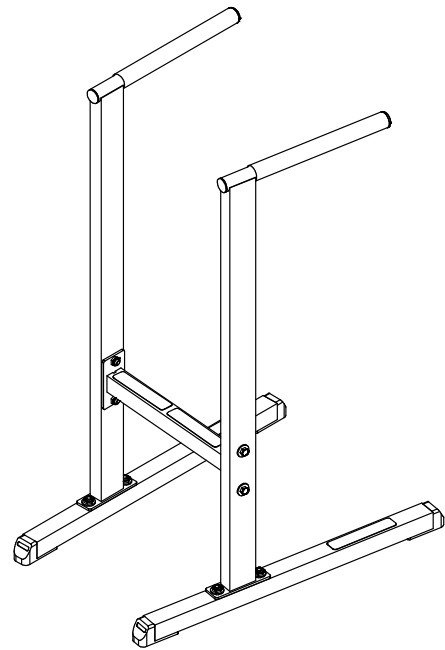
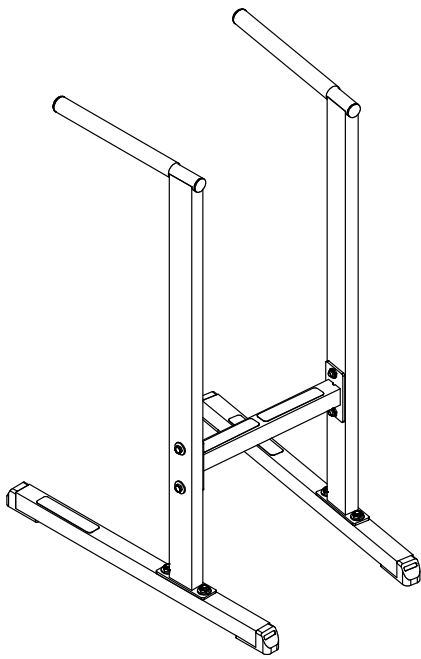

Important Safety Instructions



Before beginning any fitness program, you should obtain a complete physical examination from your physician.

Il est conseillé de subir un examen médical complet avant d'entreprendre tout programme d'exercice. Si vous avez des étourdissements ou des faiblesses, arrêtez les exercices immédiatement.

Antes de comenzar cualquier programa de ejercicios, deberías tener un examen físico con su doctor.

When using exercise equipment, you should always take basic precautions, including the following:

- Read all instructions before using the GDIP-59. These instructions are written to ensure your safety and to protect the unit.
- Do not allow children on or near the equipment.
- Use the equipment only for its intended purpose as described in this guide. Do not use accessory attachments that are not recommended by the manufacturer. Such attachments might cause injuries.
- Wear proper exercise clothing and shoes for your workout, no loose clothing.
- Use care when getting on or off the unit.
- Do not overexert yourself or work to exhaustion.
- If you feel any pain or abnormal symptoms, stop your workout immediately and consult your physician.
- Never operate the unit when it has been dropped or damaged. Return the equipment to a service center for examination and repair.
- Never drop or insert objects into any opening in the equipment.
- Always check the unit before each use. Make sure that all fasteners are secure and in good working condition.
- Do not use the equipment outdoors or near water.

Personal Safety During Assembly

- It is strongly recommended that a qualified dealer assemble the equipment.
Assistance is required.
- Before beginning assembly, please take the time to read the instructions thoroughly.
- Read each step in the assembly instructions and follow the steps in sequence. Do not skip ahead. If you skip ahead, you may learn later that you have to disassemble components and that you may have damaged the equipment.
- Assemble and operate the GDIP-59 on a solid, level surface. Locate the unit a few feet from the walls or furniture to provide easy access.

Before You Begin



Retain this Owner's Manual for future reference!

To maximize your use of the equipment please study this Owner's Manual thoroughly. Please retain this manual for future reference or parts information.

Thank you for purchasing the GDIP-59.

This gym is part of the Body-Solid line of quality strength training machines, which let you target specific muscle groups to achieve better muscle tone and overall body conditioning.

Unpacking the Equipment

The GDIP-59 is carefully tested and inspected before shipment. We have shipped the unit in several pieces that require assembly. Ask for assistance during the assembly process. Carefully unpack the boxes and lay the pieces on the floor near the area where you plan to use the equipment.

The GDIP-59 is designed for your enjoyment. By following these precautions and using common sense, you will have many safe and pleasurable hours of healthful exercise with your Body-Solid GDIP-59.

After assembly, you should check all functions to ensure correct operation. If you experience problems, or if any items are missing, first recheck the assembly instructions to locate any possible errors made during assembly. If you are unable to correct the problem, call the dealer from whom you purchased the machine or call 1-800-556-3113 for the dealer nearest you.

Obtaining Service

Please use this Owner's Manual to make sure that all parts have been included in your shipment. When ordering parts, you must use the part number and description from this Owner's Manual. Use only Body-Solid replacement parts when servicing this unit. Failure to do so will void your warranty and could result in personal injury.

For information about product operation or service, check out the official Body-Solid website at www.bodysolid.com or contact an authorized Body-Solid dealer or a Body-Solid factory-authorized service company or contact Body-Solid customer service, *M-F 8:30am-5:00pm CST*, at one of the following:



Toll Free: (800) 556-3113

Local: (708) 427-3555

Fax: (708) 427-3556



E-mail: service@bodysolid.com

or write to:



**Body-Solid, Inc.
Service Department
1900 S. Des Plaines Ave.
Forest Park, IL 60130 USA**

Body-Solid continually seeks ways to improve the performance, specifications and product manuals in order to ensure that only superior products are released from our factories. Please take the time to carefully read through this manual thoroughly. Instructions contained in this document are not intended to cover all details or variations possible with Body-Solid equipment, or to cover every contingency that may be met in conjunction with installation, operation, maintenance or troubleshooting of the equipment. Even though we have prepared this manual with extreme care, neither the publisher nor the author can accept responsibility for any errors in, or omission from, the information given. Should additional information be required, or should situations arise that are not covered by this manual, the matter should be directed to your local Body-Solid representative, or the Service Department at Body-Solid Inc. in Forest Park, Illinois.

Any Questions?
Call (800) 556-3113

Preparations



CAUTION: To set up this unit, you will need assistance. Do not attempt assembly by yourself.

You must review and follow the instructions in this Owner's Manual. If you do not assemble and use the GDIP-59 according to these guidelines, you could void the Body-Solid warranty.

CAUTION !

Obtain assistance! Do not attempt to assemble the GDIP-59 by yourself. Review the Installation Requirements before proceeding with the following steps.

Required Tools

The basic tools that you must obtain before assembling the GDIP-59 include but are not limited to:

- Standard Wrench Set
- Metric Wrench Set
- Adjustable Wrench
- Allen Set
- Rubber Mallet
- Silicone Spray Oil
- Knife

Installation Requirements

Follow these installation requirements when assembling the GDIP-59:

Set up the GDIP-59 on a solid, flat surface.

A smooth, flat surface under the machine helps keep it level. A level machine has fewer malfunctions.

Provide ample space around the machine.

Open space around the machine allows for easier access and a more comfortable workout.

Insert all bolts in the same direction.

For aesthetic purposes, insert all bolts in the same direction unless specified (in text or illustrations) to do otherwise.

Leave room for adjustments.

Tighten fasteners such as bolts, nuts, and screws so the unit is stable, but leave room for adjustments. Do not fully tighten fasteners until instructed in the assembly steps to do so.

Fill out and mail the warranty card.

To benefit from the best and most comprehensible warranty in the fitness industry, completely fill out and mail the warranty card enclosed with the unit.

Assembly Instructions



Assembly of the GDIP-59 takes professional installers about 1 hour to complete.

Professional installers are highly recommended!

If this is the first time you have assembled this type of equipment, plan on significantly more time. However, if you acquire the appropriate tools, obtain assistance, and follow the assembly steps sequentially, the process will take time, but is fairly easy.

Assembly Tips

Read all "Notes" on each page before beginning each step.

While you may be able to assemble the GDIP-59 using the illustrations only, important safety notes and other tips are included in the text.

Some pieces may have extra holes that you will not use. Use only those holes indicated in the instructions and illustrations.

IMPORTANT!

Before you begin you should look at the quick reference guide that shows all hardware parts (in actual size) along with the corresponding component numbers in the assembly instructions.

To find out the length of a particular bolt, measure its shank (the long, narrow part beneath the head) using the ruler below. Refer to the following diagram:

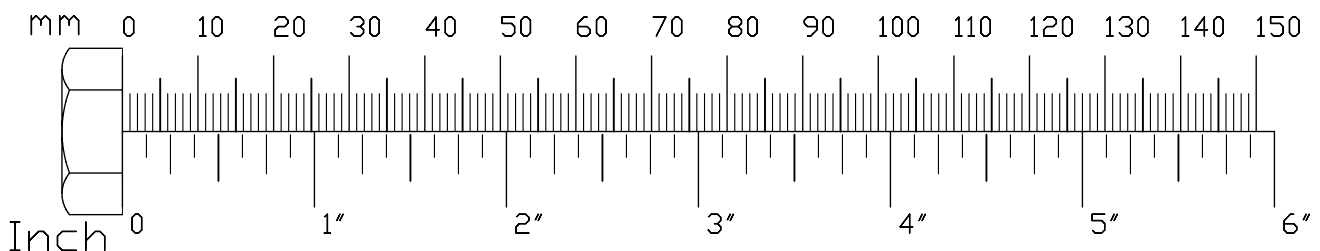
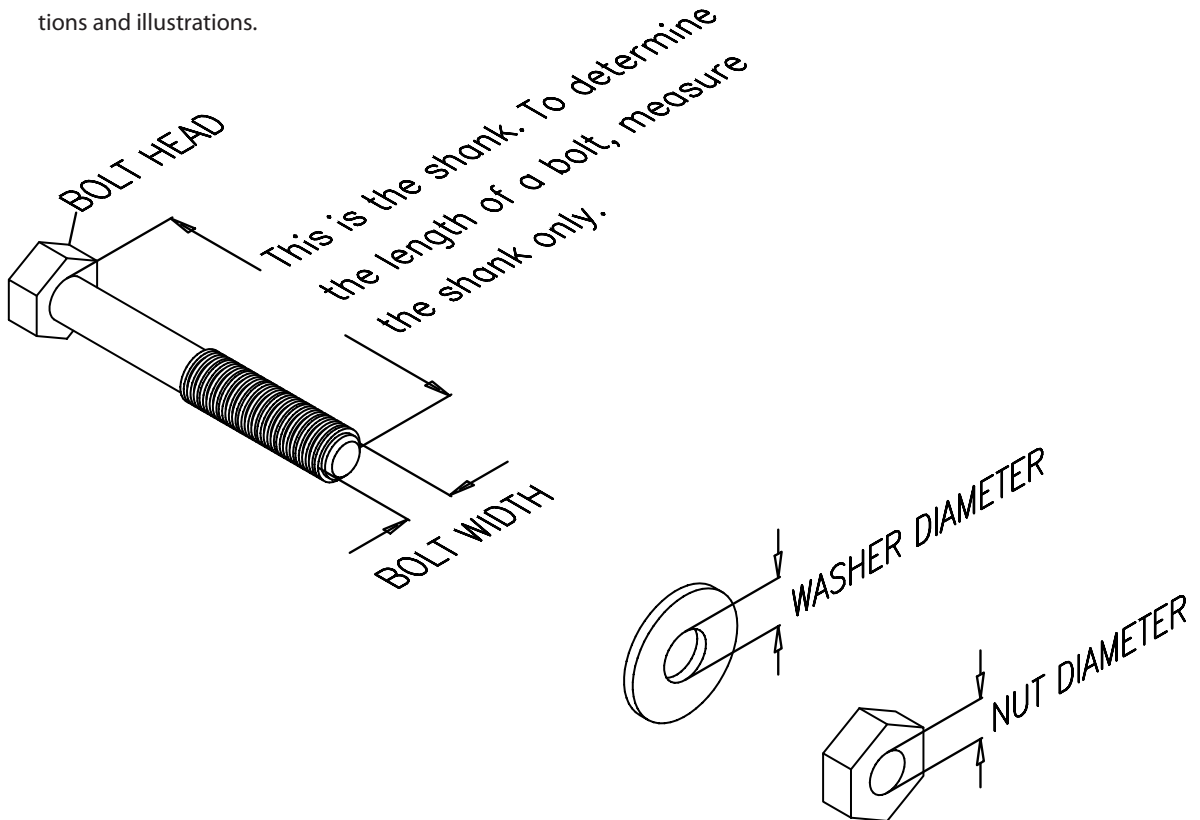

STEP

1

Be careful to assemble all components in the sequence they are presented.

NOTE: Wrench tighten all hardware at the end of this step.

- A. Insert two Foot Caps (5) into both Base Frames (C).
- B. Insert a Round End Cap (8) into both Base Frames (C).
- C. Insert a Round End Cap (6) into both Upright (A).
- D. Attach No Slip Tape (7) onto both Base Frames (C).
- E. Attach two No Slip Tape (7) onto Cross Bar (B).
- F. Connect Upright (A) to Base Frame (C) by using:
Two 2 (M12x70 carriage bolt)
Two 4 (M12 washer)
Two 3 (M12 nylon lock nut)
- G. Connect Upright (A) to Base Frame (C) by using:
Two 2 (M12x70 carriage bolt)
Two 4 (M12 washer)
Two 3 (M12 nylon lock nut)
- H. Connect Crossbar (B) to both Upright (A) and secure using:
Four 1 (M12x65 hex head bolt)
Four 4 (M12 washer)
Four 3 (M12 nylon lock nut)

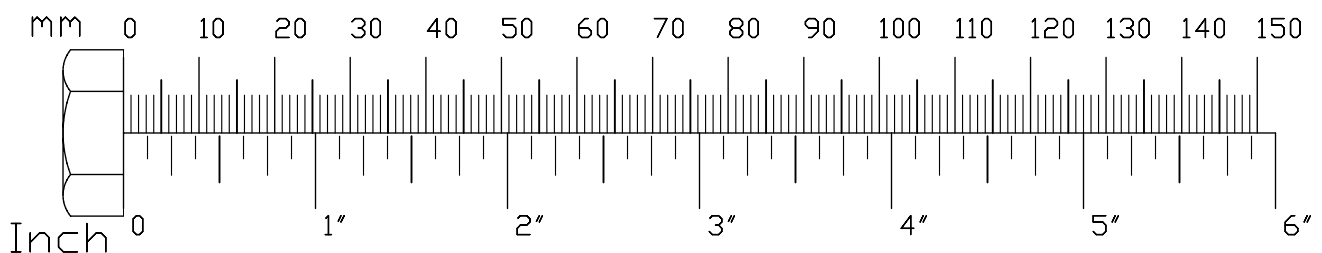

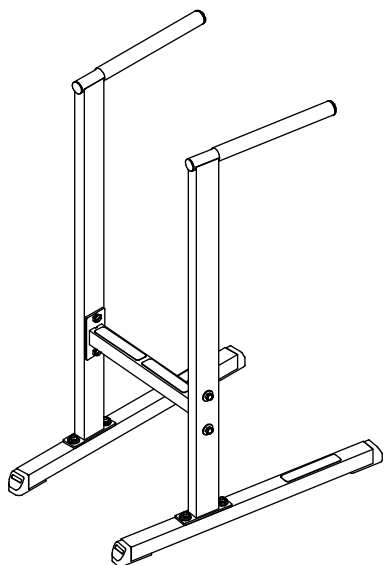

Above shows Step 1 assembled and completed.

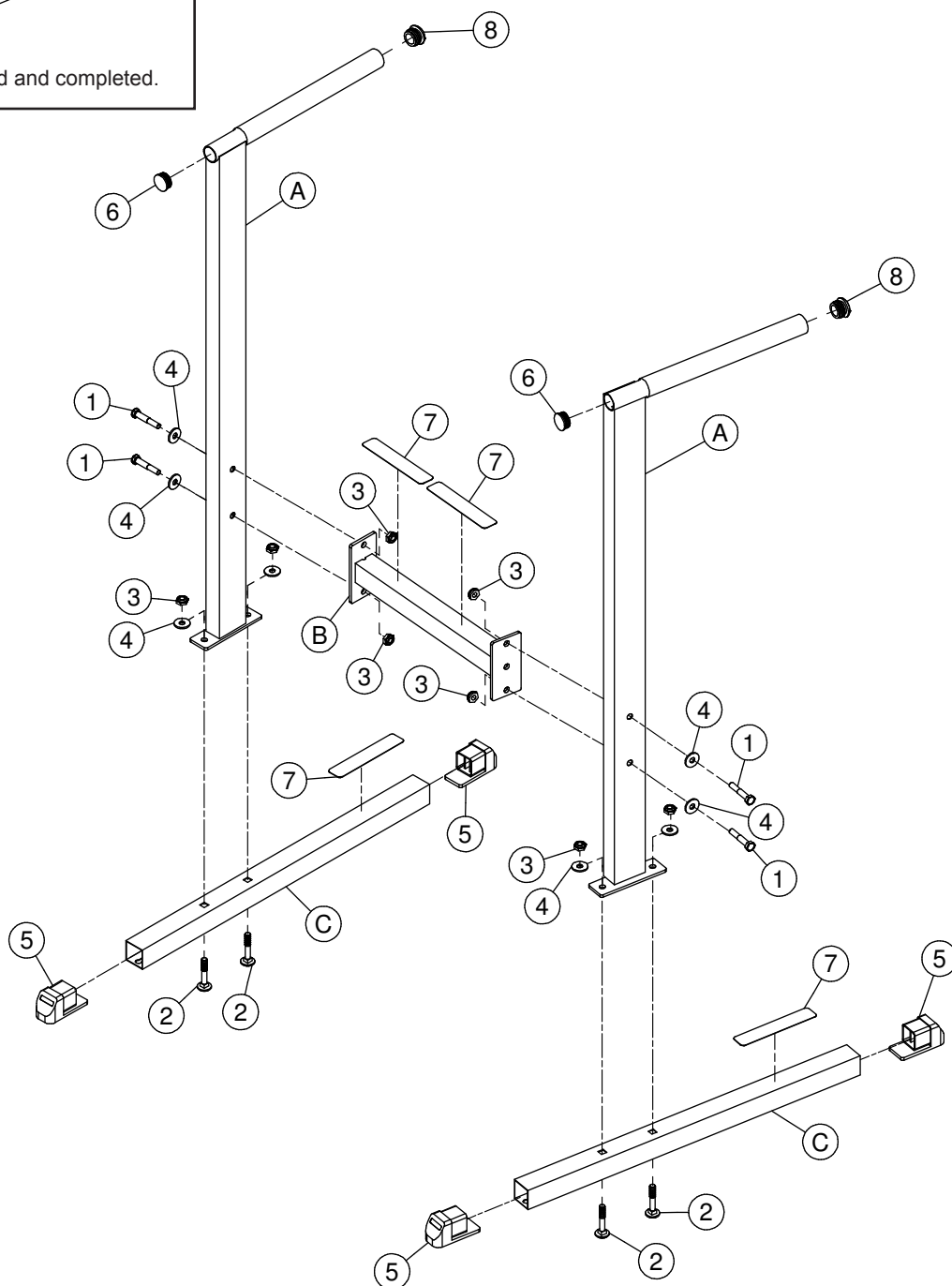

Mainframe Parts List

Part#	Qty	Description	
A	2	UPRIGHT	
B	1	CROSSBAR	
C	2	BASE FRAME	50 x 1.38T x 960L

Part numbers are required when ordering parts.

Hardware List

Part#	Qty	Description		
1	4	HEX HEAD BOLT	M12x65	
2	4	CARRIAGE BOLT	M12x70	
3	8	NYLON LOCK NUT	M12	
4	8	WASHER	M12x34	
5	4	FOOT CAP	2" x 2"	(9211-024)
6	2	ROUND END CAP	φ 38	(9211-018)
7	4	NO SLIP TAPE	38x195	(9310-030)
8	2	ROUND END CAP	φ 38	(9211-099)
9	2	FOAM GRIP	φ 37 x 3T x 410L	(9162-019)
10	1	WARNING STICKER		(9440-105)
11	1	MAINTENANCE LABEL		(9440-103)
12	1	BODYSOLID LOGO		(9440-027)
13	1	BODYSOLID PLASTIC PLATE		(9440-199)

Part numbers are required when ordering parts.

Hardware (To Scale)

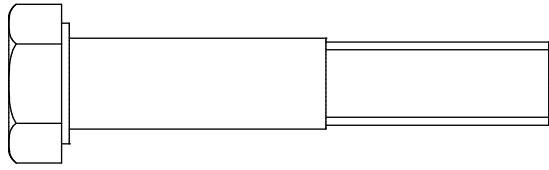

Part# 1

M12x65

Hex Head Bolt

Qty. 4

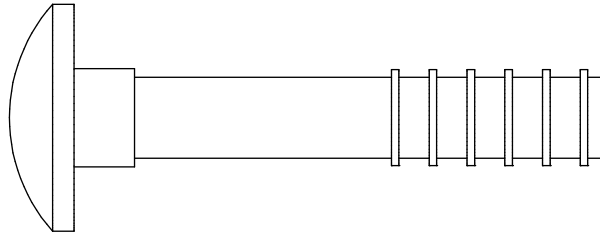

Part# 2

M12x70

Carriage Bolt

Qty. 4

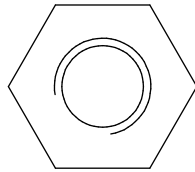

Part# 3

M12

Nylon Lock Nut

Qty. 8

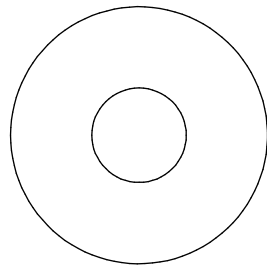
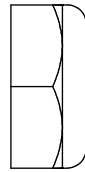

Part# 4

M12

Washer

Qty. 8

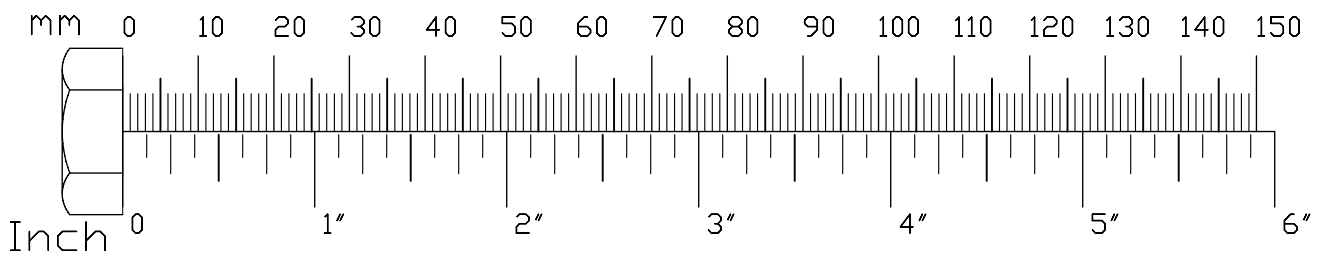
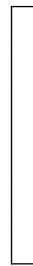

Exploded View

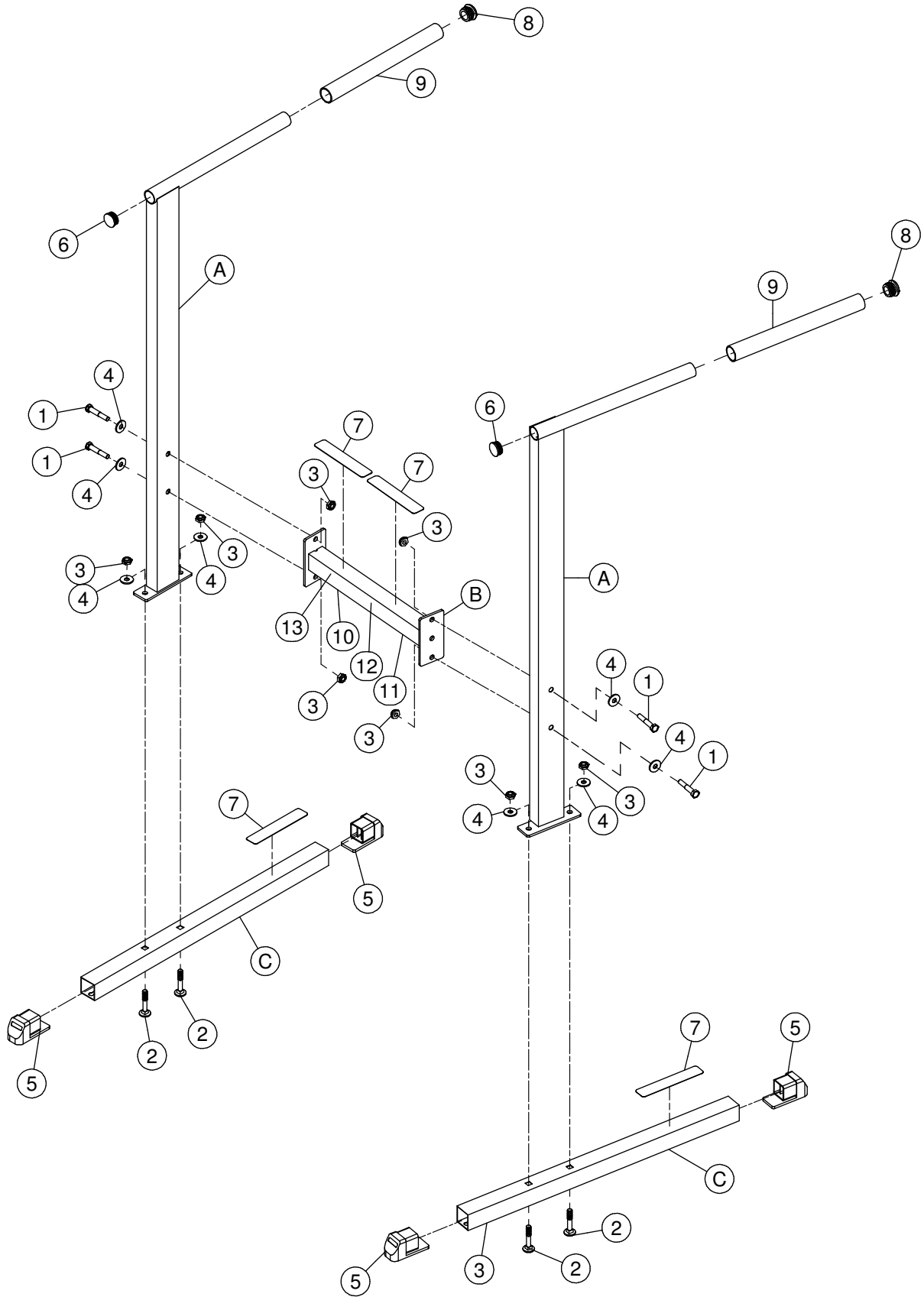

Notes

Notes

Body-Solid[®]
Built for Life

1900 S. Des Plaines Ave.
Forest Park, IL 60130
(800) 556-3113
Hours: M-F 8:30 - 5:00

www.bodysolid.com