

Body-Solid®

Built for Life

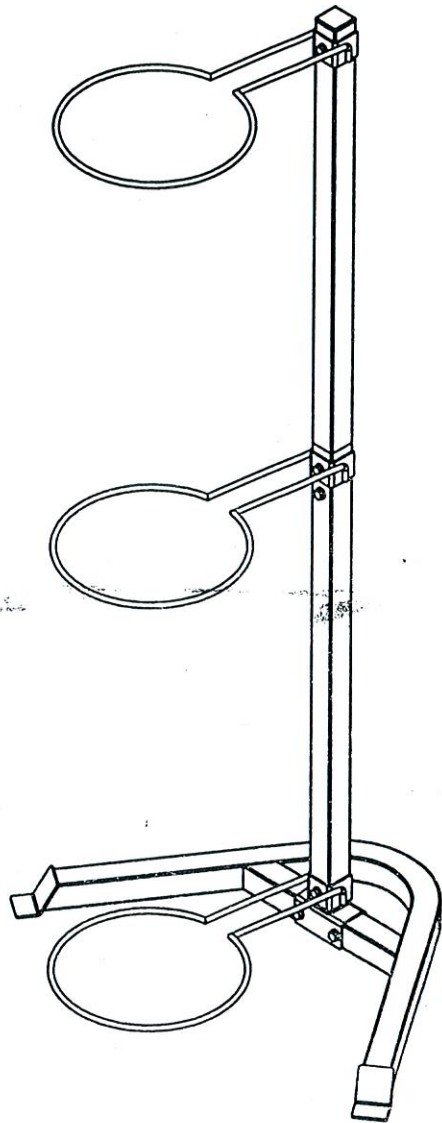

GSR10

Assembly & Instructions
OWNER'S & MANUAL

V GSR10-092614

GSR10 Hardware Illustration

Part #1 HEX HEAD BOLT M10x70mm

QTY. 4

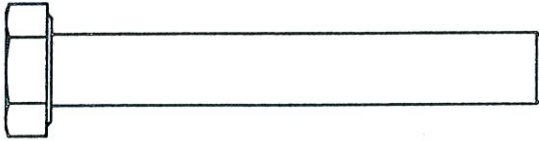

Part #2 HEX HEAD BOLT M10x20mm

QTY. 4

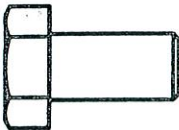

Part #3 FLAT WASHER M10

QTY. 16

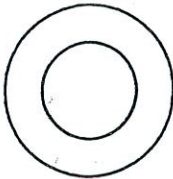

Part #4 NYLON LOCK NUT M10

QTY. 4

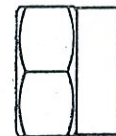

MM 0 10 20 30 40 50 60 70 80 90 100 110 120 130 140 150

Inch 0 1" 2" 3" 4" 5" 6"

GSR10 Parts List/Illustration

Part#	Qty	Description
A	1	BASE FRAME
B	1	LOWER UPRIGHT FRAME
C	1	UPPER UPRIGHT FRAME
D	3	SHELF
5	1	50x50mm END CAP

STEP**1**

Be careful to assemble all components in the sequence they are presented.

NOTE:

Finger tighten all hardware in this step. Wrench tighten ALL hardware at the end until the last step. Some components may be pre-assembled.

Option 1: Two Tiers Stability Ball Rack

- 1A. Attach Lower Upright Frame (B) to Base frame (A) using:**
2 - (#1) M10x70mm Hex Head Bolt
4 - (#3) M10 Flat Washer
2 - (#4) M10 Nylon Lock Nut
- 1B. Attach two Shelves (D) to Lower Upright Frame (B) using:**
2 - (#1) M10x70mm Hex Head Bolt
4 - (#3) M10 Flat Washer
2 - (#4) M10 Nylon Lock Nut
- 1C. Attach End Cap (5) to Lower Upright Frame (B).**

Note: Each shelf is designed to hold stability ball. The maximum weight capacity is 5lbs per shelf. Any greater weight will deform the shelf and void your warranty.

STEP
1

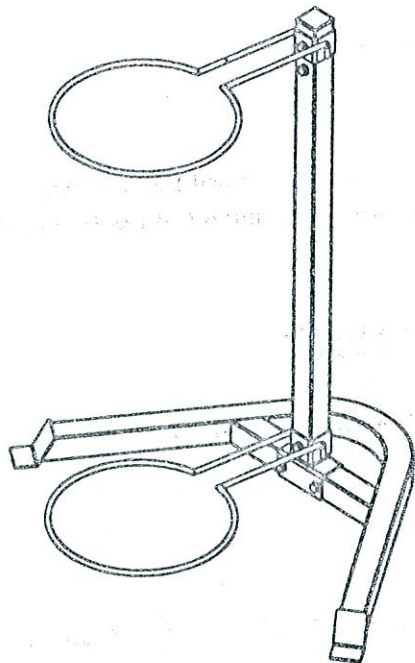

Above shows Step 1 assembled and completed.

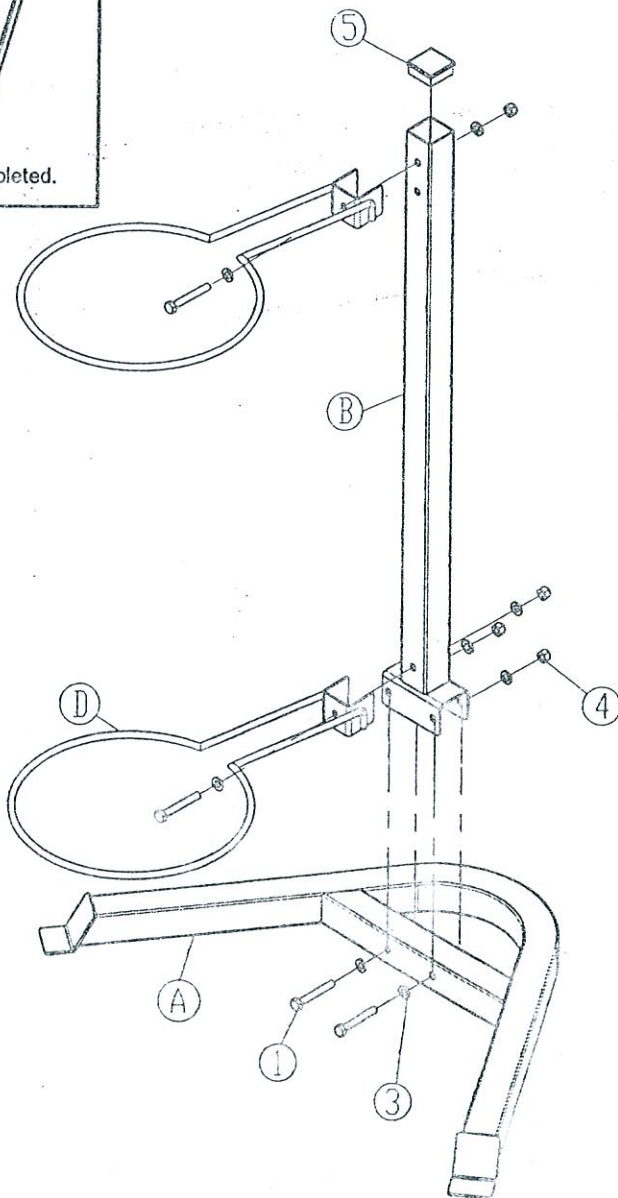

STEP

1

Be careful to assemble all components in the sequence they are presented.

NOTE:

Finger tighten all hardware in this step. **DO NOT** wrench tighten until the last step. Nylon lock nuts will not fully screw onto bolts, they must be wrench tighten to fully go on.

Option 2: Three Tiers Stability Ball Rack

- 1A. Attach Lower Upright Frame (B) to Base frame (A) using:**
- 2 - (#1) M10x70mm Hex Head Bolt**
 - 4 - (#3) M10 Flat Washer**
 - 2 - (#4) M10 Nylon Lock Nut**
- 1B. Attach Upper Upright Frame (C) to Lower Upright Frame (B) using:**
- 3 - (#2) M10x20mm Hex Head Bolt**
 - 3 - (#3) M10 Flat Washer**

STEP
1

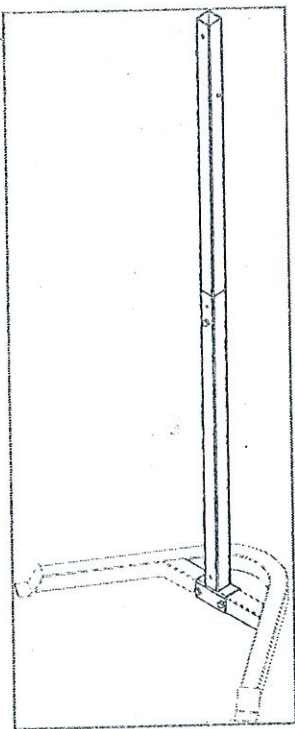

Above shows Step 1 assembled and completed.

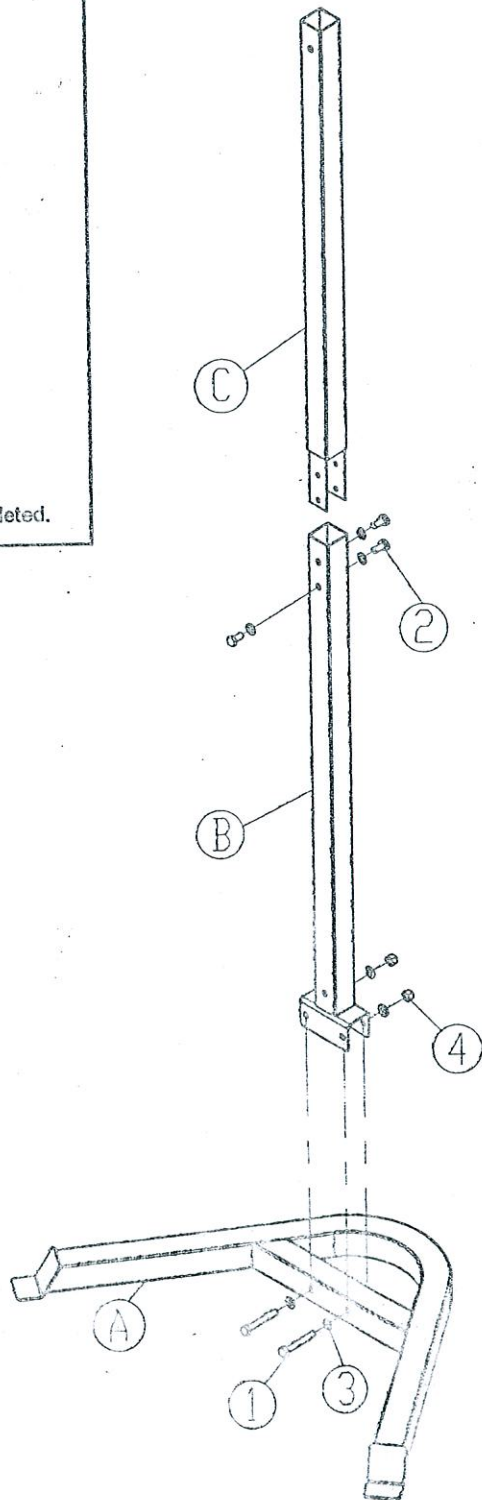

STEP
2

Be careful to assemble all components in the sequence they are presented.

NOTE:

Wrench tighten ALL hardware at the end of STEP 2A. Nylon lock nuts will not fully screw onto bolts, they must be wrench tightened to fully go on.

2A. Attach Three Shelves (D) to Upright Frames (B&C) using:

2 - (#1) M10x70mm Hex Head Bolt

1 - (#2) M10x20mm Hex Head Bolt

5 - (#3) M10 Flat Washer

2 - (#4) M10 Nylon Lock Nut

2B. Attach End Cap (5) to Upper Upright Frame (C).

Note: Each shelf is designed to hold stability ball. The maximum weight capacity is 5lbs per shelf. Any greater weight will deform the shelf and void your warranty.

STEP
2

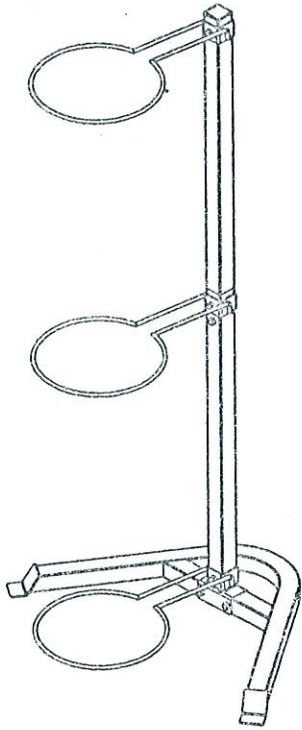

Above shows Step 2 assembled and completed.

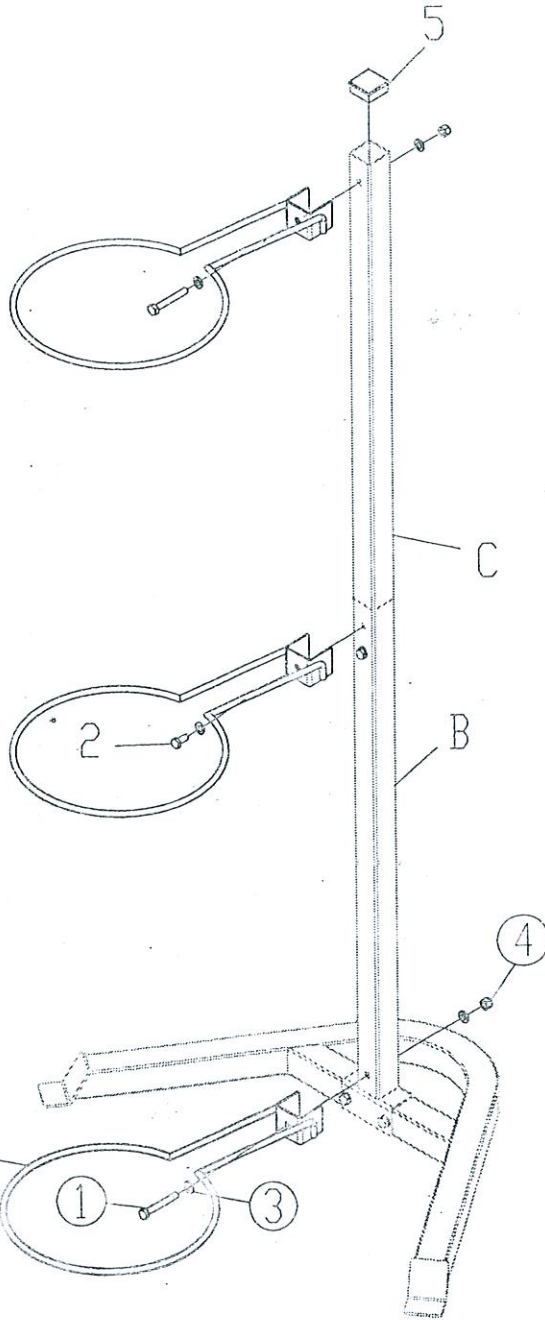

GSR10 Exploded View

