

BFVK10
OWNER'S MANUAL

BEFORE YOU BEGIN

Thank you for purchasing the Best Fitness BFVK10. This gym is part of the Best Fitness quality strength training machines, which lets you target specific muscle groups to achieve better muscle tone and overall body conditioning.

To maximize your use of the equipment please study this Owner's Manual thoroughly.

Unpacking the Equipment

The BFVK10 is carefully tested and inspected before shipment. We have shipped the unit in several pieces that require assembly. Ask for assistance during the assembly process.

Carefully unpack the boxes and lay the pieces on the floor near the area where you plan to use the equipment.

Be careful to assemble all components in the sequence presented in this guide.

If any items are missing, contact the dealer from whom you purchased the unit or call 1-800-556-3113 for the dealer nearest you.

IMPORTANT SAFETY INSTRUCTIONS

Before beginning any fitness program, you should obtain a complete physical examination from your physician.

Il est conseillé de subir un examen médical complet avant d'entreprendre tout programme d'exercice. Si vous avez des étourdissements ou des faiblesses, arrêtez les exercices immédiatement.

Antes de comenzar cualquier programa de ejercicios, deberías tener un examen físico con su doctor.

When using exercise equipment, you should always take basic precautions, including the following:

- Read all instructions before using the BFVK10. These instructions are written to ensure your safety and to protect the unit.
- Do not allow children on or near the equipment.
- Use the equipment only for its intended purpose as described in this guide. Do not use accessory attachments that are not recommended by the manufacturer. Such attachments might cause injuries.
- Wear proper exercise clothing and shoes for your workout, no loose clothing.
- Use care when getting on or off the unit.
- Do not overexert yourself or work to exhaustion.
- If you feel any pain or abnormal symptoms, stop your workout immediately and consult your physician.
- Never operate unit when it has been dropped or damaged. Return the equipment to a service center for examination and repair.
- Never drop or insert objects into any opening in the equipment.
- Always check the unit and its cables before each use. Make sure that all fasteners and cables are secure and in good working condition.
- Do not use the equipment outdoors or near water.

Personal Safety During Assembly

- It is strongly recommended that a qualified dealer assemble the equipment. Assistance is required.
- Before beginning assembly, please take the time to read the instructions thoroughly.
- Read each step in the assembly instructions and follow the steps in sequence. Do not skip ahead. If you skip ahead, you may learn later that you have to disassemble components and that you may have damaged the equipment.
- Assemble and operate the BFVK10 on a solid, level surface. Locate the unit a few feet from the walls or furniture to provide easy access.

The BFVK10 is designed for your enjoyment. By following these precautions and using common sense, you will have many safe and pleasurable hours of healthful exercise with your Best Fitness BFVK10.

After assembly, you should check all functions to ensure correct operation. If you experience problems, first recheck the assembly instructions to locate any possible errors made during assembly. If you are unable to correct the problem, call the dealer from whom you purchased the machine or call 1-800-556-3113 for the dealer nearest you.

Obtaining Service

Please use this Owner's Manual to make sure that all parts have been included in your shipment. When ordering parts, you must use the part number and description from this Owner's Manual. Use only Best Fitness replacement parts when servicing this machine. Failure to do so will void your warranty and could result in personal injury.

For information about product operation or service, go to www.bestfitness.com or contact an authorized Best Fitness dealer or a Best Fitness factory-authorized service company or contact Best Fitness customer service at one of the following:

Toll Free: 1-800-556-3113
Phone: 1-708-427-3555 ext. 5
Fax: 1-708-427-3598

Or write to: Best Fitness
Service Department
1900 S. Des Plaines Ave.
Forest Park, IL 60130 USA

Retain this Owner's Manual for future reference. Part numbers are required when ordering parts.

SAFETY GUIDELINES

Successful resistance training programs have one prominent feature in common...safety. Resistance training has some inherent dangers, as do all physical activities. The chance of injury can be greatly reduced or completely removed by using correct lifting techniques, proper breathing, maintaining equipment in good working condition, and by wearing the appropriate clothing.

- 1. It is highly recommended that you consult your physician before beginning any exercise program. This is especially important for individuals over the age of 35, or persons with pre-existing health problems.**
- 2. Always warm up before starting a workout. Try to do a total body warm up before you start. It is especially important to warm up the specific muscle groups you are going to be using. This can be as simple as performing a warm up set of high repetitions and light weight for each exercise.**
- 3. Use proper form. Focus on only working the muscle groups intended for the exercise you are doing. If there is strain elsewhere, you may need to re-evaluate the amount of weight that is involved with the lift. Keeping proper form also includes maintaining control through an entire range of motion.**
- 4. Breathe properly. Inhale during the eccentric phase of the exercise, and exhale during the lifting, or concentric phase. Never hold your breath during any part of an exercise.**
- 5. Always wear the appropriate clothing and shoes when exercising. Wearing comfortable athletic shoes with good support and loose fitting, breathable clothing will reduce the risk of injury.**
- 6. Maintaining equipment in proper operating condition is of utmost importance for a safe resistance training program. Pulleys and cables should be checked for wear frequently and replaced as needed. Equipment should be lubricated as indicated by the manufacturer.**
- 7. Read and study all warning labels on this machine. It is absolutely necessary that you familiarize yourself and all others with the proper operation of this machine prior to use.**
- 8. Keep hands, limbs, loose clothing and long hair well out of the way of all moving parts.**
- 9. Do not attempt to lift more weight than you can control safely.**
- 10. Inspect the machine daily for loose or worn parts. If a problem is found do not allow the machine to be used until all parts are tightened or worn or defective parts are repaired or replaced.**

ASSEMBLY INSTRUCTIONS

Assembly of the BFVK10 takes professional installers about 1 hour to complete. If this is the first time you have assembled this type of equipment, plan on significantly more time.

PROFESSIONAL INSTALLERS ARE HIGHLY RECOMMENDED!

However, if you acquire the appropriate tools, obtain assistance, and follow the assembly steps sequentially, the process will take time, but is fairly easy.

Assembly Tips

Read all "Notes" on each page before beginning each step.

While you may be able to assemble the BFVK10 using the illustrations only, important safety notes and other tips are included in the text.

Some pieces may have extra holes that you will not use. Use only those holes indicated in the instructions and illustrations.

NOTE: To find out the length of a particular bolt, measure its shank (the long, narrow part beneath the head). Refer to the following diagram:

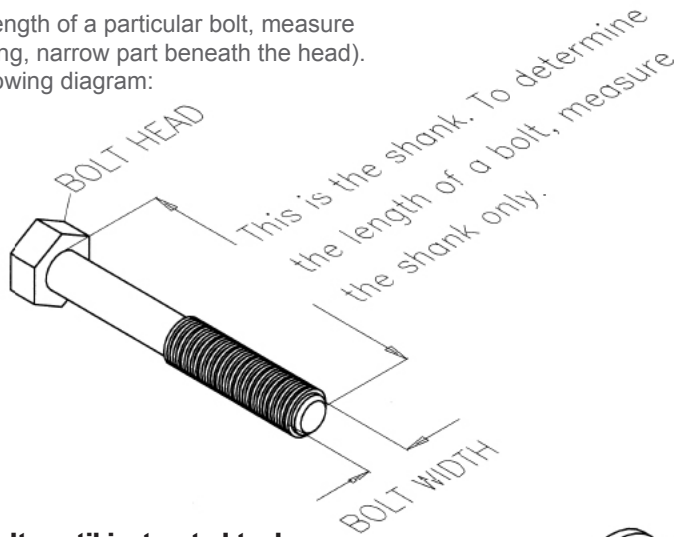

Do not fully tighten bolts until instructed to do so.

Note: After assembly, you should check all functions to ensure correct operation. If you experience problems, first recheck the assembly instructions to locate any possible errors made during assembly.

If you are unable to correct the problem, call the dealer from whom you purchased the machine or call 1-800-556-3113 for the dealer nearest you.

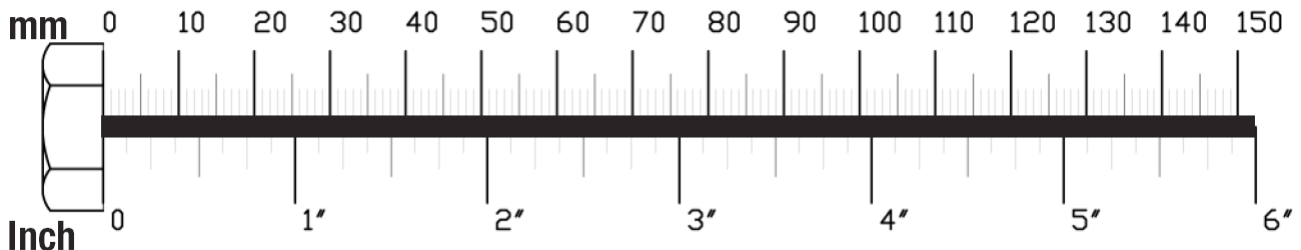
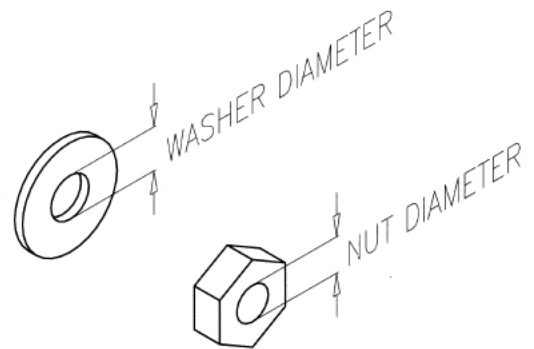

STEP

1

Be careful to assemble all components in the sequence they are presented.

NOTE:

Finger tighten all hardware in this step. Do Not wrench tighten until end of step 3.

- A. Attach Foot Tube Assembly (A) to Middle Tube Assembly 1 (B) using:
Two 11 (M10x65 carriage bolt)
Four 20 (ϕ 10 large washer)
Two 30 (M10 nylon lock nut)
- B. Attach second Foot Tube Assembly (A) to Middle Tube Assembly+ 1 (B) using:
Two 11 (M10x65 carriage bolt)
Four 20 (ϕ 10 large washer)
Two 30 (M10 nylon lock nut)
- C. Install four Endcaps (1) to both Foot Tube Assemblies (A) as shown in the diagram.

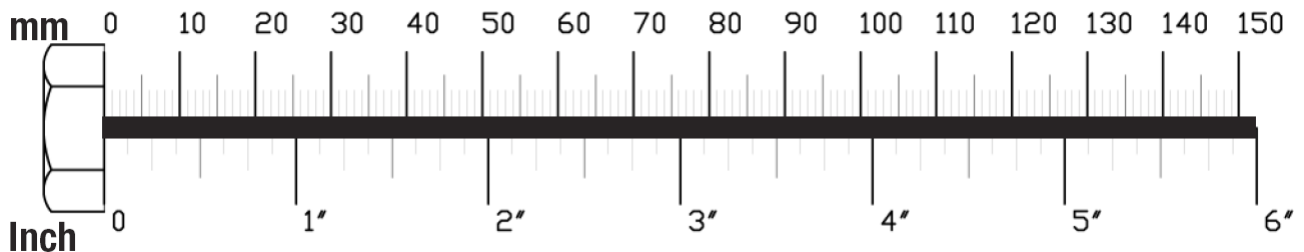

STEP
1

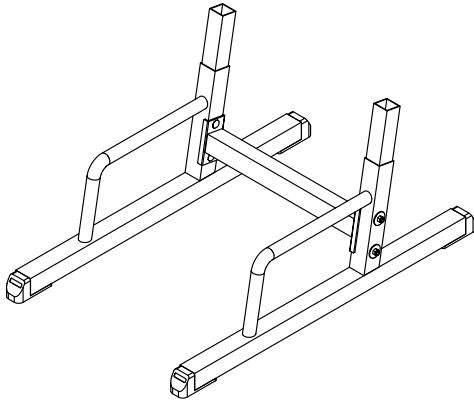

Above shows STEP 1 assembled and completed.

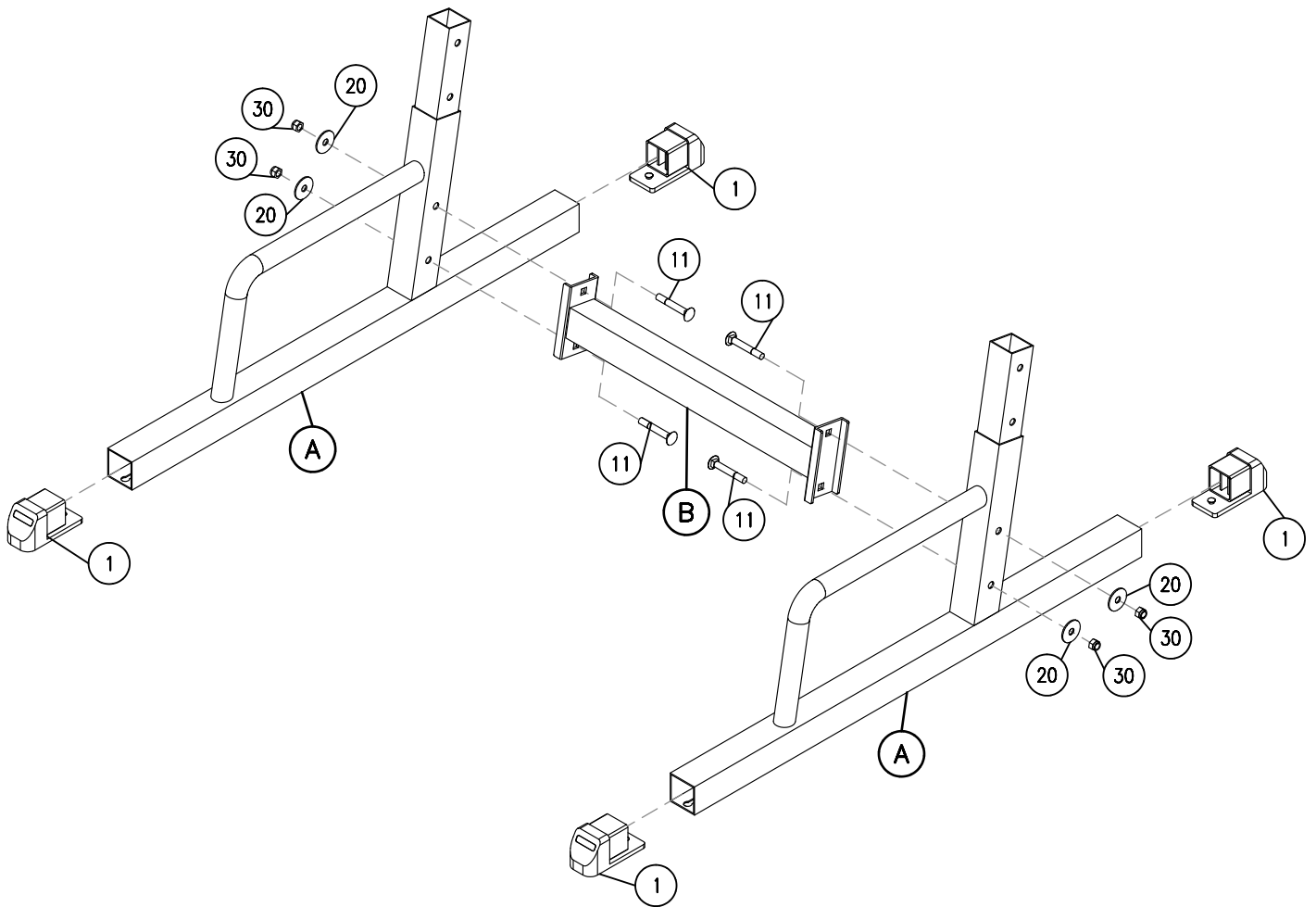

STEP**2**

Be careful to assemble all components in the sequence they are presented.

NOTE:

Finger tighten all hardware in this step. Do Not wrench tighten until end of step 3.

- A. Slide Elbow Tube Assembly (C) onto Foot Tube Assembly (A).
- B. Attach Middle Tube Assembly 2 (D) to Elbow Tube Assembly (C) using:
Four 11 (M10x65 carriage bolt)
Four 20 (ϕ 10 large washer)
Four 30 (M10 nylon lock nut)
- C. Secure Elbow Tube Assembly (C) to Foot Tube Assembly (A) using:
Four 12 (M10x65 hex head bolt)
Four 20 (ϕ 10 large washer)
Four 30 (M10 nylon lock nut)
- D. Install Elbow Pads (K) to Elbow Tube Assembly (C) using:
Four 13 (M8x65 hex head bolt)
Four 22 (ϕ 8 spring washer)
Four 21 (ϕ 8 washer)
- E. Connect two Handle Tubes (H) to Elbow Tube Assembly (C) using:
Two 14 (M10x20 hex head bolt)
Two 23 (ϕ 10 washer)

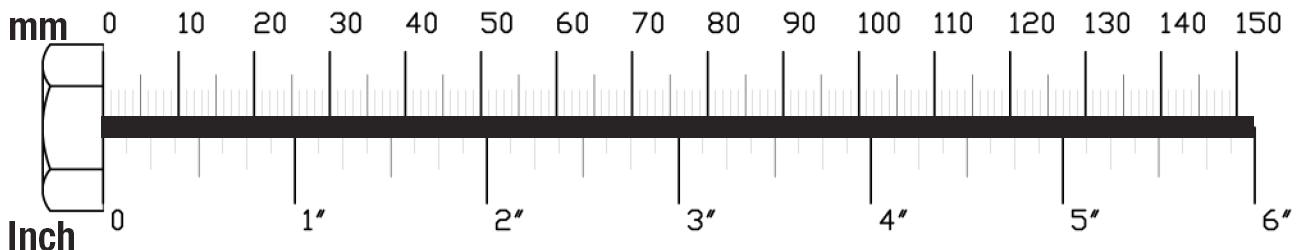

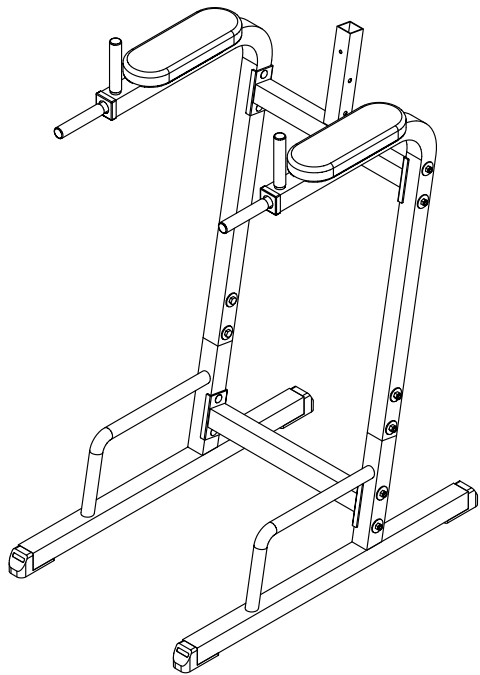

Above shows STEP 2 assembled and completed.

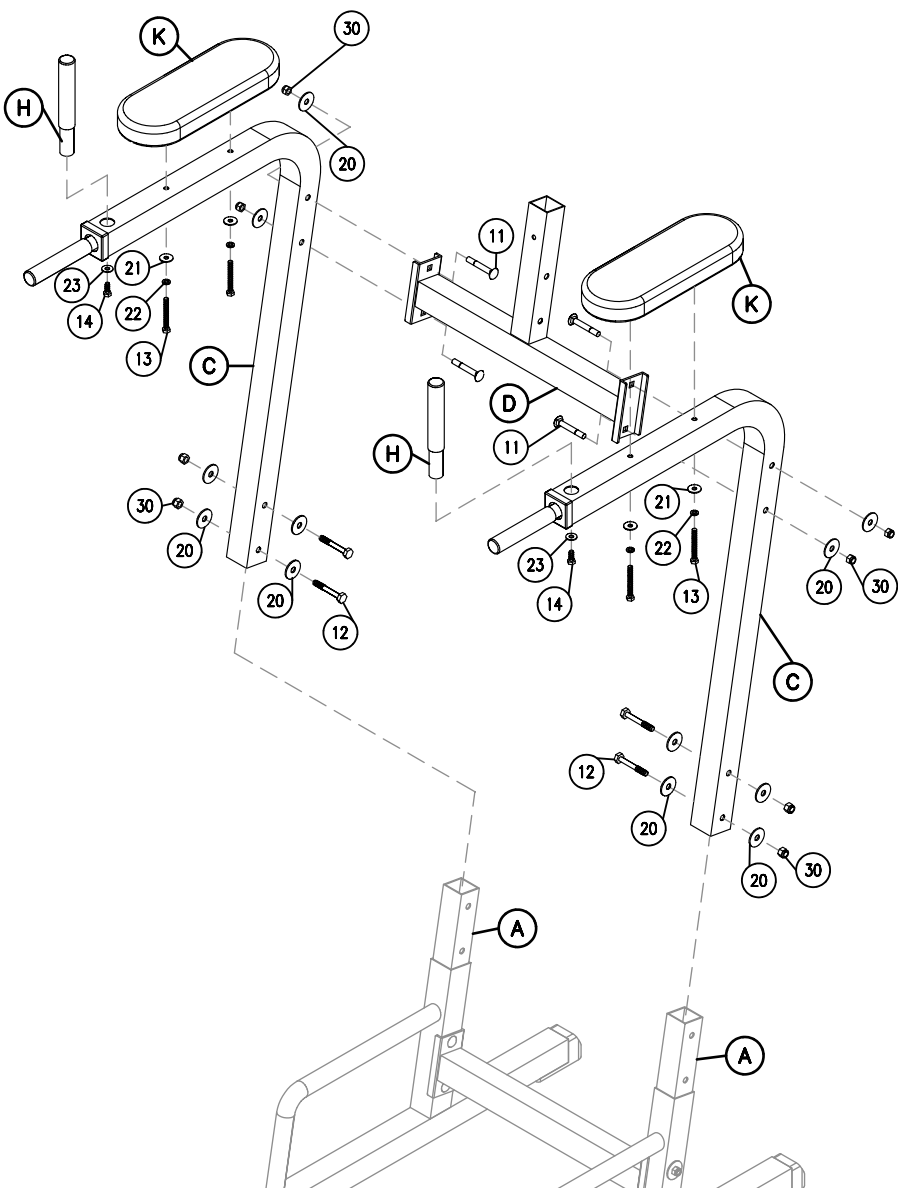

STEP**3**

Be careful to assemble all components in the sequence they are presented.

NOTE:

Finger tighten all hardware in this step. Do Not wrench tighten until end of step 3.

- A. Slide Back Tube Assembly (E) onto Middle Tube Assembly 2 (D) and connect using:
Two 12 (M10x65 hex head bolt)
Four 20 (ϕ 10 large washer)
Two 30 (M10 nylon lock nut)
- B. Affix Back Pad (M) onto Back Tube Assembly (E) using:
Two 13 (M8x65 hex head bolt)
Two 22 (ϕ 8 spring washer)
Two 21 (ϕ 8 washer)
- C. Slide Lat Bar Assembly (F) onto Back Tube Assembly (E) and secure using:
One 12 (M10x65 hex head bolt)
Two 20 (ϕ 10 large washer)
One 30 (M10 nylon lock nut)

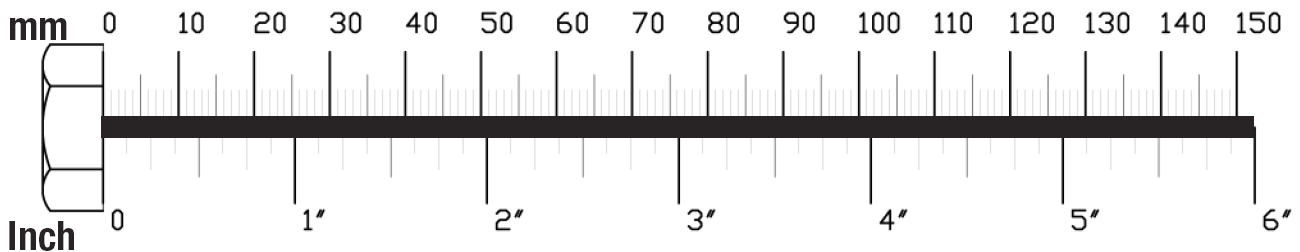

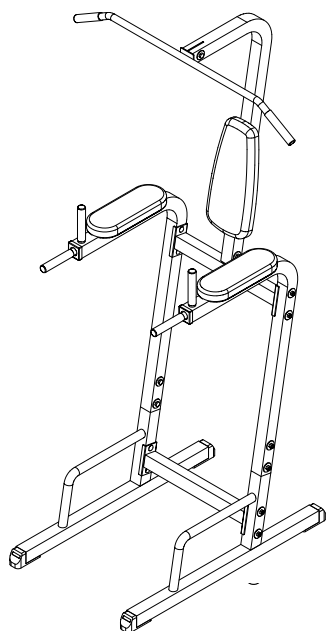

Above shows STEP 3 assembled and completed.

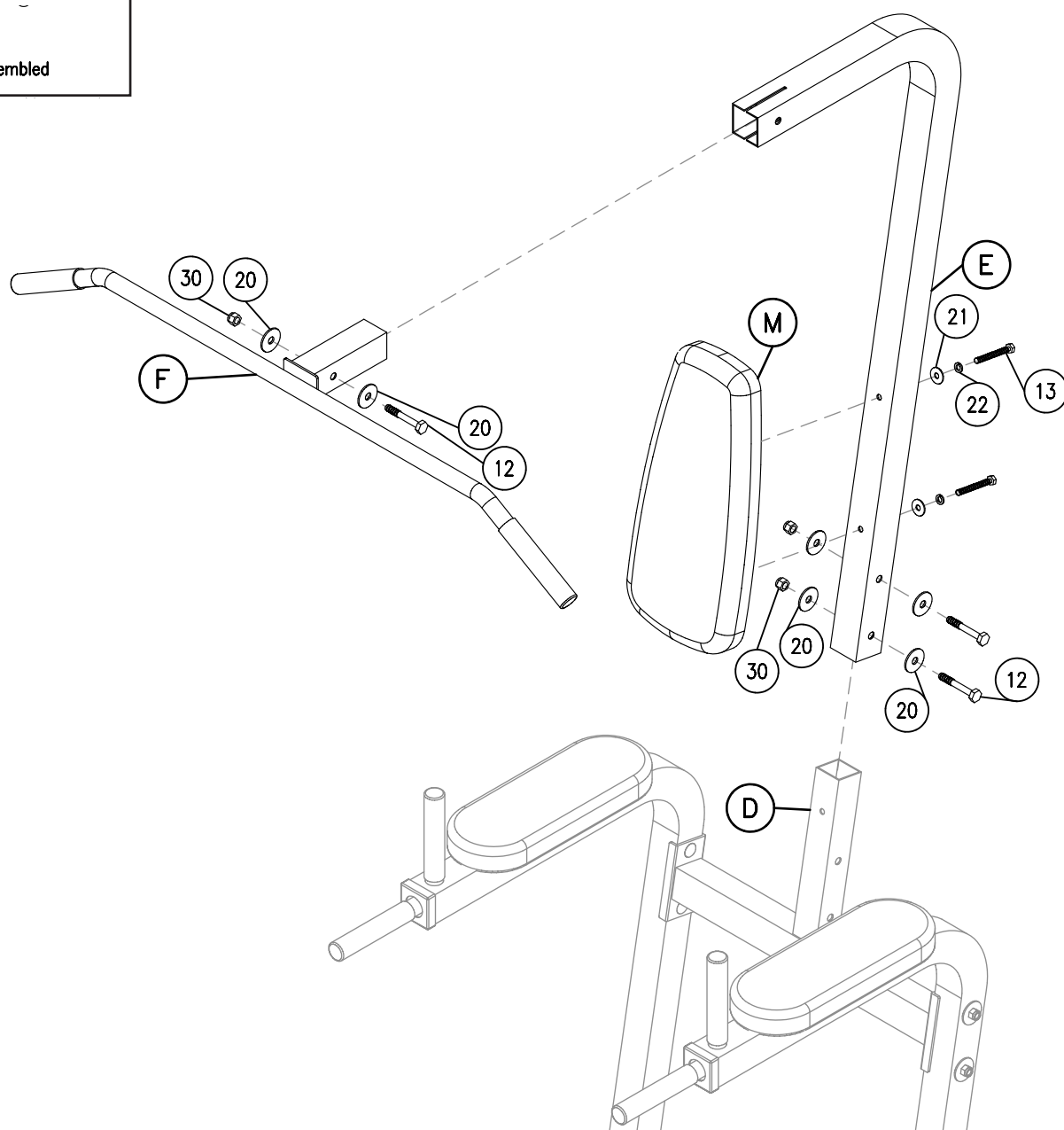

IMPORTANT SAFETY INSTRUCTIONS

Be sure that all users carefully read and understand all warning, safety and maintenance labels on the machine before each use. Failure to do so may result in serious injury. It is imperative that you retain this Owner's Manual and be sure all warning labels are legible and intact. Replacement Owner's Manuals and labels are available from your local dealer. If you have any questions about the operation, set up or maintenance of this machine please call our customer service department at 1 (800) 556-3113.

THERE IS A RISK ASSUMED BY INDIVIDUALS WHO USE THIS TYPE OF EQUIPMENT. TO MINIMIZE RISK, YOU MUST FOLLOW THESE RULES:

1. Inspect equipment before each workout. Check that all nuts, bolts, screws and pop pins are in place and fully tightened. Also, before use, check cables for signs of wear. Replace all worn parts immediately. Never use machine if any parts are damaged or missing. **FAILURE TO FOLLOW THESE RULES MAY RESULT IN SERIOUS INJURY.**
2. Keep clear of the cables and all moving parts when the machine is in use.
3. Always make sure all Snap Links are closed when doing any cable/pulley/strap exercises.
4. Exercise with care. Perform your exercises at a smooth moderate pace; never perform jerky or uncoordinated movements that may cause injury.
5. It is recommended that you should workout with a training partner.
6. Do not allow children or minors to play on or around this equipment.
7. If unsure of proper use of equipment, call your local Body-Solid distributor or the Body-Solid customer service department at 1-800-556-3113.
8. **WARNING:** Consult your physician before starting your exercise program. For your own safety, do not begin any exercise program without proper instruction. RAL8-6-03 WC-54

#DWRULE-4
Warning Label for Rules

MAINTENANCE SCHEDULE		D	W
Check the function and integrity of the following components. As noted, inspect equipment before each workout. Replace all damaged, broken or worn components immediately.		A	E
		I	K
		L	L
		Y	L
Cables:	Check tension, end fittings, and coating	✓	
	Check that locking nut at weight stack is tight		✓
Upholstery:	Wipe down and dry	✓	
	Clean and condition		✓
Frame:	Wipe down and dry	✓	
	Polish / Wax		✓
Chrome:	Wipe down and dry	✓	
	Polish / Lubricate		✓
Nuts / Bolts / Fasteners:	Tighten and / or adjust as needed		✓
Guide Rods:	Lubricate and clean		✓
Linear Rods:	Lubricate and clean		✓
Seat Sleeves:	Lubricate and clean		✓
Adjustments / Locking Pins / Tightening Knobs			✓
Weight Stack Pins			✓
Warning Instruction Labels			✓
Springs / Pop Pins		✓	
Anti Skid Surfaces			✓
Hand Grips / Rollers			✓

For Body-Solid Customer Service
Call 1-800-556-3113
#MSSTKR0803

#DWSM-5
Warning Label for Maintenance



Warning

Safety and Maintenance of Cables

Although Best Fitness provides the highest quality of materials and workmanship in its products, the fact remains that component parts eventually wear out over time and with use. **This is particularly true with reference to pliable moving parts such as cables.** In spite of any expressed and/or implied warranties, intervening factors such as improper use, unusually heavy use, improper installation, improper alignment, poor maintenance, etc. serve to drastically reduce the usable life and safety of cables.

Be advised that dangerous conditions can arise even during warranty periods and that any expressed and/or implied warranties **Do Not Negate** the owner's responsibility to thoroughly, carefully and daily inspect all cables on this machine.

Serious injury can occur if you are struck by falling weights or moving parts. The risk that you assume by using this type of equipment can be reduced by following a few simple steps:

Cable inspection should be performed daily. Inspect all cables, the nylon coating on all cables and the area near the fittings at each end of each cable.

Replace any damaged or worn cables immediately. Do not allow the machine to be used until damaged or worn cables are replaced.

Important: Cables are wear items. It is your responsibility to prevent unexpected breakage. The actual wire strands, the fittings and the nylon coating itself must all be scrutinized. Using or allowing a machine to be used with a suspect cable can result in serious injury. The nylon coating on a cable is essential for cable life and safety. Visually inspect all cables and pulleys. Look at the cables as they travel around the cams and pulleys. A cable that is wearing may exhibit a "ballooned" or broken coating in the area that passes over the pulley. Damage to the coating is an early warning signal. A cable should be replaced if the nylon coating is missing, is damaged in anyway, has pulled or shrunk from the fittings at the end of the cables, or if it is discolored. Discoloration of the cable coating is an early indication of internal problems such as wear or fraying.

Annual cable replacement (semiannual in multi-user settings) is strongly recommended as an additional precaution. The rate at which cables wear depends on many factors including: number of users, number of repetitions, weight setting, misuse, abuse, etc. Because of this, periodic cable replacement is not a sufficient safeguard against unexpected breakage.

Nothing short of a thorough, careful, daily inspection constitutes an adequate safety program.

WARNING

Safety and Maintenance of Cables

IMPORTANT: Cables are wear items. It is your responsibility to prevent unexpected breakage. **Cable inspection should be performed daily.** Inspect all cables, the nylon coating on all cables, and the area near the fitting at each end of each cable. **Replace any damaged or worn cable immediately.** Do not allow the machine to be used until damaged or worn cables are replaced. Using or allowing a machine to be used with a suspect cable can result in serious injury. See Owner's Manual for more information.

For Body-Solid Customer Service
Call **1-800-556-3113**

WARNINGS, SAFETY & MAINTENANCE

Precision craftsmanship assures Best Fitness's ability to consistently deliver products of the highest standards. Our products have been carefully designed to ensure safe, efficient long term operation.

However, it must be realized that safe use of this equipment requires that owners carefully read and follow the Best Fitness use recommendations, warnings, and maintenance guidelines in this Owners Manual.

Routine inspection and maintenance is of critical importance to ensure the maximum safety and performance of the BFVK10. Best Fitness uses the highest quality materials available, but wear is inevitable. Therefore, you must carefully inspect your equipment as outlined in the Maintenance Schedule on the next page.

Be advised that dangerous conditions can arise even during a warranty period. A warranty does not negate the owner's responsibility to thoroughly, carefully and daily inspect the machine.

Including maintaining the equipment the owner's responsibility is also to:

- Be sure to always provide adequate supervision to all end-users.
- Be sure to instruct all end-users of proper usage.
- Be sure all supervisors and personal trainers who instruct end-users on equipment are properly trained and know the function and importance of every adjustment and setting. Also, be sure these trainers provide proper instruction to end-users on the fundamentals of strength training.

CABLES:

- While the machine is not in use. Carefully run your fingers along the cable to feel for thinning or bulging areas. Replace cables immediately at the first sign of damage or wear. Do not use equipment until damaged cable has been replaced.
- Visually inspect the cables for fraying, cracking, peeling or discoloration.
- Check slack in cables and re-adjust cable tension if needed.
- Check that jam nut at Weight Stack is tight.

UPHOLSTERY:

- Wipe down after every workout.
- Periodically take the time to use a mild soap or a mild vinyl upholstery cleaner. Avoid using any abrasive cleaner not intended for use on vinyl.
- Keep sharp or pointed objects out of your pockets and clear of all upholstery.

NUTS/BOLTS/FASTENERS:

- Periodically inspect all nuts and bolts. Tighten if needed. If bolts seem to loosen periodically, use Loctite 242 for a long-term cure.
- Go through a re-tightening sequence periodically to ensure that all hardware is properly tensioned.

GUIDE RODS:

- Wipe clean with a dust free rag. Lubricate with a Silicon or Teflon based lubricant.

ADJUSTMENTS / LOCKING PINS / TIGHTENING KNOBS:

- Check all pieces for signs of visible wear or damage.
- Check springs in Snap Links and Pop Pins for proper tension and alignment.
- If the spring sticks or has lost its rigidity, replace it immediately.

ANTI-SKID SURFACES:

- Replace if they appear worn or become slippery.

WARNING INSTRUCTION LABELS:

- Inspect and familiarize yourself with all safety warnings and other user information on decals.



MAINTENANCE SCHEDULE	DAILY	WEEKLY	LATEST DATE ENTRY						
CABLES: CHECK TENSION, END FITTINGS, AND COATING. CHECK THAT JAM NUT AT WEIGHT STACK IS TIGHT.	✓	✓							
UPHOLSTERY: WIPE DOWN AND DRY CLEAN AND CONDITION.	✓	✓							
FRAME: WIPE DOWN AND DRY POLISH/WAX	✓	✓							
CHROME: WIPE DOWN AND DRY POLISH/LUBRICATE	✓	✓							
NUTS/BOLTS/FASTENERS: TIGHTEN AND / OR ADJUST AS NEEDED		✓							
GUIDE RODS: LUBRICATE AND CLEAN		✓							
LINEAR RODS: LUBRICATE AND CLEAN		✓							
SEAT SLEEVES: LUBRICATE AND CLEAN		✓							
ADJUSTMENTS / LOCKING PINS / TIGHTENING KNOBS		✓							
WEIGHT STACK PINS		✓							
WARNING INSTRUCTION LABELS		✓							
SPRINGS / POP PINS	✓								
ANTI-SKID SURFACES		✓							
HAND GRIPS / ROLLERS		✓							
FOR BEST FITNESS CUSTOMER SERVICE: 1-800-556-3113	*Make several copies of this page to keep track of your maintenance. You can print more copies of this page by going to: http://www.bodysolid.com/support/bestfitness/docs.html								

PHRASES, TERMS, TIPS & GUIDELINES

BEGINNER'S GUIDELINES

- Work out at least two times a week.
- Include six to eight exercises that train major muscle groups.
- Perform two or three sets of at least eight to 12 repetitions.

AEROBIC

Exercise that primarily uses oxygen to burn fuel at low to moderate levels of intensity. Running and jogging are examples of aerobic exercise.

ANAEROBIC

Exercise that primarily uses the body's stored fuel for energy. Intense weight lifting is an example of an anaerobic exercise.

ATROPHY

Decrease of a muscle caused by the decrease in the size of its cells because of inactivity.

BALLISTIC STRETCHING

A stretching technique that involves a bouncing or bobbing movement during the stretch. The final position is not held. This is not a recommended stretching technique.

BREATHING

Never hold your breath during any part of an exercise. Holding your breath may cause severe intra-thoracic pressure and raise blood pressure leading to dizziness, blackout or other complications. The rule of thumb is to exhale on exertion and inhale on the return part of the exercise.

CARDIOVASCULAR

Referring to the heart, lungs, and other periphery systems involved in the transport of oxygen throughout the body.

CHALLENGE YOUR MUSCLES

All strength training should progress gradually, using increases in weight until your goals are reached. Then, change your workout to include increased reps or a higher weight resistance. Alter the order of your exercises, perform multiple sets or different exercises to maintain results or reach new goals.

CHANGE ROUTINE

Beginner's please note: If you want to make changes in the exercise routine that you do, wait until about the six to eight week point. Advanced lifters may want to change routines to avoid plateaus in gaining size or strength.

CIRCUIT TRAINING

Exercise stations that consist of various combinations of weight training, flexibility, calisthenics, and aerobic exercise.

CONCENTRIC MUSCLE ACTION

The muscle shortens while contracting against resistance.

ECCENTRIC MUSCLE ACTION

The muscle lengthens while contracting against resistance.

EXERCISE FREQUENCY

Exercise each muscle group 2-3 times per week. Allow a minimum of 48 hours rest for each muscle group worked. If you are doing a total-body workout, three training sessions per week, performed on every second day, is adequate.

EXERCISE LARGE MUSCLES FIRST

You should work your large muscle groups first (ie. squat, bench press, lat pulldown) before you exercise your small muscle groups (ie. biceps curls, tricep pressdowns, lateral raises).

EXERCISE PROGRAM DURATION

A weight training routine should take anywhere from 45 minutes to one hour to complete. Add another 20 to 60 minutes when you include stretching, warm-up, aerobics and cool-down.

GIVE YOUR MUSCLES A REST

You'll get the most out of strength training if you give your muscles at least 48 hours rest to recover and rebuild between strength training workouts.

HYPERTROPHY

Enlargement of a muscle caused by an increase in the size of its cells in response to weight training.

INTENSITY

The degree to which the body is worked during exercise.

ISOKINETIC EXERCISE

Resistance is given at a fixed velocity of movement with accommodating intensity. A machine that moves you through an entire range of motion at a preset speed and will not change no matter how much pressure is put forth by the individual.

ISOMETRIC EXERCISE

Contracts the muscle statically without changing its length. Example: Attempting to lift a weight heavier than you can handle, but cannot move.

ISOTONIC EXERCISE

Shortens and lengthens the muscle through a complete range of motion. This defines weight training with full range of motion.

MUSCLE FATIGUE

Fatigue is when you can't possibly do another rep without sacrificing form.

MUSCULAR ENDURANCE

The ability to perform repetitive muscular contractions against some resistance.

MUSCULAR STRENGTH

The maximum force that can be applied by a muscle during a single maximum contraction.

OSTEOPOROSIS

A decrease in bone density.

PLYOMETRIC EXERCISE

A technique that includes specific exercises which encompass a rapid stretch of a muscle eccentrically, followed immediately by a rapid concentric contraction of that muscle for the purpose of facilitating and developing a forceful explosive movement over a short period of time. Examples of these are using medicine balls for upper extremity and depth jumping for lower extremity.

PHRASES, TERMS, TIPS & GUIDELINES

STARTING RESISTANCE LEVEL

If you begin weight training at too high a level, you risk serious injury. You will also develop poor form, which will hinder your efforts and discourage you. Use this as a guideline: if you cannot lift the weight eight times with proper form, the weight is too heavy. Similarly, don't choose too light a weight; the last two or three repetitions of your set should be difficult.

POWER

Power is the rate of performing work. Power during a repetition is defined as the weight lifted times the vertical distance the weight is lifted divided by the time to complete the repetition. Power during a repetition can be increased by lifting the same weight the same vertical distance in a shorter period of time. Power can also be increased by lifting a heavier resistance the same vertical distance in the same period of time as a lighter resistance.

PROGRESS GRADUALLY

Increase reps before increasing resistance. Reduce rest intervals between sets to increase intensity.

PROGRESSIVE RESISTANCE

The principle of continually adding more weight to a specific exercise as your muscles become stronger to adapt to the heavier weights.

PROPER FORM

Focus on the proper motion of the exercise and concentrate on the specific muscles being used. Do not sacrifice proper form to lift heavier weight or to perform more repetitions. Proper form also means lifting in a smooth, fluid motion. If you feel strain elsewhere, you should re-evaluate the amount of weight you are lifting or have a qualified professional critique your exercise motion.

PROPER POSTURE

Maintaining proper posture will greatly reduce chances of injury and maximize exercise benefit. When standing always keep your feet shoulder-width apart. Do not lock your knees. Locking your knees can put unnecessary strain on them. Keep your back flat and straight, making sure not to twist or arch it in order to complete a repetition.

PROPER TECHNIQUE

To get the most out of strength training and to reduce the chance of injury, use proper weight training techniques. These include working your muscles through their full range of motion (but not locking any joints), lifting at a speed at which you can control the weight and stop easily if necessary.

RANGE OF MOTION

Moving through a complete range of motion (ROM) allows the muscles to stretch before contraction and increases the number of muscle fibers being recruited. This produces maximum contraction and force. By working the full ROM, flexibility will be maintained and possibly increased.

REPETITION

A repetition is one complete movement of an exercise. It normally consists of two phases: the concentric muscle action, or lifting of the resistance, and the eccentric muscle action, or lowering of the resistance.

REPETITION MAXIMUM (RM)

This is the maximum number of repetitions per set that can be performed at a given resistance with proper lifting technique. Thus, a set at a certain RM implies the set is performed to momentary voluntary fatigue. 1RM is the heaviest resistance that can be used for one complete repetition of an exercise. 10 RM is a lighter resistance that allows completion of 10 (but not 11) repetitions with proper exercise technique.

REST INTERVAL

Allow a brief pause between sets to give your muscles a chance to partially recover before working them again. For power and muscle size development allow a 3 to 4 minute rest interval between sets. For muscular endurance and definition allow a 30 second rest interval. For strength training allow a 60 to 90 second rest interval.

RISK SHOULD NOT EXCEED BENEFIT

If the risk of a specific exercise exceeds its potential benefit, it is best to stay on the conservative side. There are several ways to work specific muscle groups. Choose those that provide minimal risk. Ask a fitness professional for guidance.

ROUTINE

The specific exercises, sets, reps and weight for a specific body part.

SET

This is a group of repetitions performed continuously without stopping. While a set can be made up of any number of repetitions, sets typically range from 1 to 15 repetitions.

SMALL MUSCLE GROUP EXERCISE

Single joint movement and isolation exercises (i.e. bicep curls, tricep pressdowns and leg extensions).

SPEED OF MOVEMENT

Strength training movements should be slow and controlled. Do not use momentum to complete an exercise movement. Momentum puts unnecessary stress on tendons, ligaments and joints. Using momentum in your exercise movements does not develop increased strength.

STATIC STRETCHING

A stretching technique that involves holding a specific muscle or muscle group at a desired length for a certain period of time. This type of stretching is highly recommended.

STOP TRAINING IF YOU FEEL PAIN

If you feel pain during a specific exercise stop immediately. Any continuation may aggravate an existing injury. Re-evaluate your routine to make sure that you are doing a proper warm up. Decrease the amount of weight you are lifting. Talk to a qualified personal trainer, health professional or your doctor.

STRENGTH

Strength is the maximal amount of force a muscle or muscle group can generate in a specified movement pattern at a specified velocity of movement.

WARM UP

This cannot be stressed enough. Many workout-related injuries can be avoided by a proper warm up routine. Try to do a total body warm up before you start training. A good example of a total body warm up is using a stationary bike, treadmill, elliptical, rowing or skiing machine. It is especially important to warm up specific muscle groups you are going to be using. Your muscles need a 5 to 15 minute warm up as well as a brief cool down. This can be as simple as performing a warm up set of high repetitions and light weight (25% to 50% of your training weight) for each exercise.

WORKOUT

The routine, specific exercises, weights, sets, and reps for one or more body parts.

NUTRITION

Good nutrition is a diet in which foods are eaten in proper quantities and with the needed distribution of nutrients to maintain good Health. Malnutrition, on the other hand, is the result of a diet in which there is an under consumption, overconsumption, or unbalanced consumption of nutrients that leads to disease or an increased susceptibility to disease. What is stated in the above definitions is the fact that proper nutrition is essential to good health. A history of poor nutritional choices will eventually lead to poor health consequences.

There are many substances necessary for the proper functioning of the body. Nutrients are the substances that the body requires for the maintenance of health, growth, and to repair tissues. Nutrients can be divided into six classes: carbohydrates, fats, proteins, vitamins, minerals and water. Carbohydrates, or "carbs", are nutrients that are composed of carbon, hydrogen and oxygen, and are essential sources of energy in the body. Grains, vegetables, and fruits are excellent sources of carbohydrates. It is recommended that at least 55% to 60% of the total number of calories consumed come from carbohydrates (American Diabetes Association, Diabetes & Exercise, 1990). It is further recommended that 10% or less of the total calories consumed come from simple sugars like a candy bar.

One of the many benefits of consuming foods that are high in complex carbohydrates, such as rice, pasta, and whole grain breads, is that they also typically contain dietary fiber. Dietary fiber is a term used when referring to substances found in plants that cannot be broken down by the human digestive system. Although fiber cannot be digested, it is important in helping to avoid cancers of the digestive system, hemorrhoids, constipation, and diverticular disease because it helps food move quickly and easily through the digestive system. It is recommended that people consume 20 to 30 grams of fiber per day (American Diabetes Association, Diabetes & Exercise, 1990). Excellent sources of dietary fiber are grains, vegetables, legumes, and fruit.

Fats are an essential part of a healthy diet and serve vital functions in the human body. Among the functions performed by fats are temperature regulation, protection of vital organs, distribution of some vitamins, energy production, and formation of component parts of cell membranes. Like carbohydrates, fats are composed of carbon, hydrogen, and oxygen. However, their chemical structure is different.

Both animals and plants provide sources of fat. Saturated fats come primarily from animal sources and are typically solid at room temperature. Plant sources of saturated fats are palm oil, coconut oil, and cocoa butter. A high

intake of saturated fats is directly related to increased cardiovascular disease. Unsaturated fats are typically liquid at room temperature. Corn, peanut, canola, and soybean oil are sources of unsaturated fats. It is recommended that no more than 30% of one's diet be composed of fats. Ten percent or less of the total calories consumed should come from saturated fats. One way to reduce saturated fat intake would be to substitute margarine for butter.

Proteins are substances composed of carbon, hydrogen, oxygen, and nitrogen. Proteins are made by combining amino acids. Amino acids are nitrogen-containing building blocks for proteins that can be used for energy. Amino acids can combine in innumerable ways to form proteins, and it is estimated that tens of thousands of different types of proteins exist in the body. It is the ordering of the amino acids that provides the unique structure and function of proteins.

There are proteins in both meat products and plant products. Animal sources of protein such as milk, meat and eggs contain the eight essential amino acids (amino acids that the body cannot synthesize and therefore must be ingested). Plant sources of protein such as beans, starchy vegetables, nuts, and grains do not always contain all eight amino acids. Because of this, vegetarians must consume a variety of protein-containing foods. It is recommended that proteins make up 10% to 15% of one's daily calories. This will ensure adequate protein for growth, maintenance, and the repair of cells. Protein requirements for adults are not as high as those recommended for infants, children, and young adults. Note: individuals who are training intensely will have an increase in their protein requirements.

Vitamins are organic substances that are essential to the normal functioning of the human body. Although vitamins do not contain energy to be used by the body, these substances are essential in the metabolism of fats, carbohydrates and proteins. Because of the critical role vitamins play, it is necessary that they exist in proper quantities in the body.

Minerals are inorganic molecules that serve a variety of functions in the human body. The minerals that appear in the largest quantities (calcium, phosphorus, potassium, sulfur, sodium, chloride, and magnesium) are often called macrominerals. Other minerals are also essential to normal functioning of the body, but because they exist in smaller quantities (chromium, iron, copper, fluoride, iodine, manganese, molybdenum, selenium, and zinc) they are called microminerals.

A mineral that is often consumed in inadequate amounts by Americans is calcium. Calcium is a mineral important in the mineralization of bone, muscle contraction, and the transmission of nerve impulses. Osteoporosis is a disease

characterized by a decrease in the total amount of bone mineral in the body and by a decrease in strength of the remaining bone. This condition is most common in the elderly but may also exist in younger people who have diets inadequate in calcium or vitamin D or both.

Iron is another mineral that is often under consumed by Americans. This is especially true of women. The oxygen-carrying properties of hemoglobin (blood) depend on the presence of iron. Anemia is a condition characterized by a decreased capacity to transport oxygen in the blood, and is also common in those lacking a sufficient amount of iron intake. Red meat and eggs are excellent sources of iron. Additionally spinach, lima and navy beans, and prune juice are excellent vegetarian sources of iron.

Sodium, on the other hand, is a mineral that many Americans over-consume. High sodium intake has been linked with hypertension, as well as high blood pressure. People can substantially reduce their sodium intake by limiting consumption of processed foods and decreasing the amount of salt added to foods when cooking.

In conclusion...don't forget hydration. Water is considered an essential nutrient because of its vital role in the normal functioning of the body. Water contributes approximately 60% of the total body weight and is essential in creating an environment in which all metabolic processes occur. Water is necessary to regulate temperature and to transport substances throughout the body.

Follow these basic nutritional guidelines for gains in strength and lean muscle mass:

1. Choose your foods carefully. Try getting your carbohydrates from sources such as rice, vegetables, beans, whole grains, pasta and fruit. Good protein sources include fish, chicken, turkey, lean meat and low-fat or nonfat dairy products.
2. Minimize your fat intake.
3. Drink a minimum of 10 eight-ounce glasses of water each day.
4. Eat four to six small meals a day, about three hours apart. Small meals are more easily digested and result in greater nutrition absorption.
5. Avoid eating junk food and fast food.
6. Time your protein intake of 40-55 grams approximately 75 minutes after your workout.
7. Immediately following your workout, replenish your glycogen stores with approximately 50-75 grams of carbohydrates.

For more information on nutrition visit your local library or book store. There are many excellent books available.

EXERCISE PRESCRIPTION

Sets

Sets are defined as a combination of any number of reps of one exercise. The number of sets used in a workout is directly related to training results. Typically, two to three sets are used by intermediate and advanced lifters to achieve optimum gains in strength. Experts agree that multiple-set systems work best for the development of strength and muscular endurance. Gains will be made at a faster rate by using a multiple-set system than gains achieved through a single-set system. The use of a single set of an exercise is recommended and very effective for individuals who are untrained or just beginning a resistance training program. One-set programs might also be used for simple maintenance once you are in shape. It is important to note that low-volume set programs will increase strength in untrained individuals, but more complex physiological adaptations, such as gains in muscle mass, tone, size, and performance usually requires higher-volume set training for the best results. Multiple sets of an exercise present a more intense training stimulus to the muscles during each set. Once your desired initial fitness level has been achieved, multiple-set performances of the exercise using the proper resistance (with specific rest periods between sets) will take you to the next level of strength training, endurance, and muscular development.

Resistance Used

The amount of resistance used for a specific exercise is probably the most important variable in resistance training. When designing a resistance training program, a weight for each exercise must be chosen. The use of repetition maximums (RM): the exact resistance that allows only a specific number of repetitions to be performed, is probably the easiest method for determining a resistance. Typically, one uses a training RM target or a RM target zone. Example: If your RM zone is 8 to 12 repetitions and you cannot lift the weight at least 8 times using proper form, the weight is too heavy. On the other hand, if you can easily lift the weight 12 times, the weight is too light. In either case, the weight needs to be changed. As the strength level of the lifter changes over time, the resistance is adjusted so a true RM target or target zone resistance is used.

Rest Periods Between Sets and Exercises

One frequently overlooked variable in exercise prescription is the length of the rest period between sets and between different exercises. Your desired fitness goals will normally determine the amount of time you allow your body to rest. Exercises involving high repetitions (15 to 20) and a high number of sets (3 to 4) with short rest periods (30 seconds) between sets will raise metabolic demands. This in turn will burn excess body fat and increase muscular endurance. Short rest periods are a characteristic of circuit weight training, and the resistances used are typically lighter. This type of workout is best for trimming body fat and toning muscle. Exercises with heavier resistance and fewer sets usually have a longer resting period between sets. The results of using this method are normally increased muscular strength and mass. If the desired outcome is to gain overall muscle mass, your exercise prescription should lean toward a higher weight resistance doing 2 to 6 repetitions per set, with a rest period of 3 to 4 minutes between each set.

Rest Periods Between Workouts

The amount of rest between training sessions depends on the recovery ability of the individual. Most experts agree that three workouts per week with one day of rest between sessions allows adequate recovery, especially for the beginner. If the resistance training is not excessive, only moderate amounts of delayed muscular soreness should be experienced one day after the session. As the lifter advances and his or her body is better able to tolerate and recuperate from the resistance exercise sessions, the frequency of training can be increased. Well-conditioned athletes may be capable of, and need training frequencies of 4 to 5 days in a row to improve significantly and achieve their desired goals. When consecutive training day sequences are used, it is usually beneficial to do different exercises for the same muscle groups and use different resistances for the exercises. When training is performed on consecutive days, it often involves the use of a split routine (different body parts exercised each day), or a split program (different exercises for the same body part performed each day). There are many books available at the library or your local book store for the intermediate and advanced weight training enthusiast. It is also recommended that you work with a qualified personal trainer to achieve your ultimate goals.

Order of Exercise

Leaders in the field of strength and conditioning believe that working the larger muscle groups first (chest, back, legs), should take priority over training the smaller muscle groups (biceps, triceps, deltoids, calves). The reason behind this exercise order is that the exercises performed in the beginning of the workout are the ones that are going to require the greatest amount of muscle mass to perform. Hence, exercising the smaller muscle groups first will deplete the body of the energy necessary to stimulate the larger muscle groups. Arm-to-leg ordering allows for some recovery of the arm muscles while the leg muscles are exercised. "Stacking" exercises is a common practice among body builders as a way to attempt to bring about muscle hypertrophy. Stacking is loading up different exercises on the same muscle group (ie. standing bicep curls, preacher curls, one arm concentration curls). The exercise order will have a significant impact on the training stimulus stress level in a training session.

Scheduling Training

Finding the time to do it is one of the most difficult aspects of a training program. Once you have established a time to workout you should plan a training routine based on what muscles to involve on which day. As previously discussed, the larger muscle groups such as the chest, back, and legs should take priority over working the smaller muscle groups. Give your muscles at least 48 hours (but no more than 72 hours) of rest in between sessions.

TRAINING TIPS FOR BEGINNER'S

ARE YOU A "BEGINNER"?

A beginner can be classified as someone who has never touched a weight, may have lifted for a while, but has taken a substantial amount of time off, or has not consistently trained over the last six months. If you happen to fall into any of these categories, pay close attention, because the following information will be detrimental to the start of your training program.

As a beginner, one of the most common mistakes is doing too much. Because beginners often make good gains quickly, many fall into the trap of thinking that more is better. This may be true later in the training equation, but not for the novice. Some of the most common injuries occur as a result of taking on too much, too soon.

One of the questions most frequently asked is, "How much weight should I use?" Determining the weight for each exercise will vary from person to person. The weight for each exercise will be lifted in sets and repetitions. Repetition is defined as one execution of any exercise. A set is a combination of any number of repetitions of one exercise.

Experimentation at each exercise station is a good technique for determining the starting weight for an individual. Take the chest press exercise for example. Performing this exercise with a weight that can be pressed 30 times with ease will not help you achieve any particular goals. Adding the appropriate amount of weight that will allow you to perform a maximum of 8 to 12 repetitions will help you obtain the results you desire.

On the other hand, if you put too much weight on the press bar and press it 4 or 5 times, then common sense will tell you to reduce the weight, wait a few minutes, then try again. Remember, never sacrifice perfect form just for the sake of lifting heavier weight. This is a sure-fire, one-way trip down the road to injury. Making muscles work hard, with proper form is the name of the game.

Now that you understand how to test each station for your starting amount of resistance, you should know which muscles to train first. Training the large muscle groups first, such as your chest, legs, and back, should be done before training your small muscle groups like the arms, shoulders, and calves.

Starting with the large muscle groups will help you achieve and maintain quicker gains. The large muscle groups will require more stimulation and a higher intensity level than the smaller muscle groups. Training your arms with all-out intensity and training your chest immediately afterwards will not leave you with enough energy necessary to properly stimulate the muscle fibers in your chest. Moreover, because the triceps are required in chest press movements, your arm muscles will fail much more quickly than your chest muscles, which will also hold back your chest training.

As a beginner, you will find that your gains will come quickly. The excitement and enthusiasm that comes with these gains may cause you to spend even more time on your gym. Take it easy! Remember, just as too little exercise won't stimulate muscle growth...too much exercise won't either.

You need to give your body plenty of rest, especially if you're still sore from the last workout. This will keep you fresh and growing stronger. NEVER TRAIN A BODY PART THAT IS STILL SORE FROM THE PREVIOUS WORKOUT. Performing some flexibility exercises is a good way to keep the blood flowing through the sore area, but do not train these muscles again until you are feeling recovered.

Speaking of soreness, there is something else that you, as a beginner, should be aware of: If you work out - your muscles will get sore. The majority of muscle soreness comes from microtears and a build up of lactic acid in the muscle fibers. This is the result of intense exercise. Muscle soreness can become a problem when the body is pushed too fast and too quickly. As a beginner, tendons, ligaments, joints and tissues have not yet developed the ability necessary to recover from high intensity exercise. A general warm up of stretching and light calisthenics prior to exercise can possibly reduce the amount of post-exercise muscle soreness. A good cool down of stretching and cardio work may also decrease muscle soreness.

Now that we have laid a good foundation of the "do's and don'ts", let's get into something a little more specific. The Beginner's Strength Training Program. One of the best beginner's programs is the three-days-a-week routine. For example, do a whole-body workout on Monday, Wednesday and Friday. Use the other days for rest and recuperation. As previously discussed, you want to start with the large muscle groups first, then move on to the small muscle groups. Perform one exercise per muscle group that consists of 2 or 3 sets of 8 to 12 repetitions. Follow this routine for at least six to eight weeks in order for your body to establish the proper stimulation for growth.

One or two exercises per muscle group may not sound like enough to produce any results, but if you're a beginner - it most definitely will. As you continue to train and your body adapts to your exercise routine and recuperative demands you place upon it, you'll be able to add more sets and exercises to your routine.

Another point that is highly recommended is the assistance of a personal trainer. Through the use of a personal trainer you can learn the mechanics and techniques of exercise, how to use proper form to avoid injury and details on proper nutrition. A good trainer will also provide MOTIVATION.

When choosing a personal trainer, here are some tips: Choose an individual that is certified through an accredited association. This is a good way to ensure that he or she is qualified to give you what you need. Also, take a look at what kind of shape they are in. If you want to be in great shape, look for a trainer who is in great shape. They will know what it takes to get results. Here are a few recommended organizations:

- National Strength & Conditioning (719) 632-6722
- American College of Sports Medicine (317) 637-9200
- National Academy of Sports Medicine (312) 929-5101

Sample Workout Routine When Training For STRENGTH

Exercises	Reps	Sets
Leg Press / Squat	6 to 10	3 or 4
Leg Extension	8 to 12	2 or 3
Leg Curl	8 to 12	2 or 3
Calf Raise	8 to 12	2 or 3
Bench /		
Chest Press	6 to 10	2 or 3
Incline Press	8 to 12	2 or 3
Incline Pec Fly	8 to 12	2 or 3
Lat Pulldown	8 to 12	2 or 3
Seated Row	8 to 12	2 or 3
Military Press	8 to 12	2 or 3
Upright Row	8 to 12	2 or 3
Bicep Curl	8 to 12	2 or 3
Tricep Pressdown	8 to 12	2 or 3
Tricep Extension	8 to 12	2 or 3
Resistance		
Ab Crunch	20 to 30	2 or 3
Resistance		
Oblique Crunch	20 to 30	2 or 3

Rest period between sets should be about 60 to 90 seconds.

COMMON TRAINING MISTAKES

1. **Lack of Adequate Warm-Up and Inadequate Flexibility**

A warmed muscle is a more flexible muscle that's better able to lift heavier weights and work in a full range of motion. Those warmed muscles also greatly reduce your chance of training injuries.

2. **Improper Form**

The use of improper form is a good way to keep you out of the gym. Not only does improper form cause injuries, it also doesn't allow for adequate muscle-fiber stimulation.

3. **Too Much Weight**

Overloading the muscles is a good way to promote muscular growth, but packing on too much weight can cause a snowball effect of improper form, injuries, and down time from your routine.

4. **Not Enough Weight**

Not lifting enough weight will prohibit the stimulation necessary for muscular growth. Keep challenging your self to lift heavier weights on a progressive basis always maintaining proper form.

5. **Not Enough Rest Between Workouts**

If you're still sore from your previous workout, you don't have to go back at it just because it's your scheduled day. Give your body an extra day off to fully recover so when you return you will be able to give 100%.

6. **Overtraining**

It's not how much time you spend working out, but what you accomplish that really matters. Try to keep your resistance workouts within 45 to 60 minutes per session.

7. **Poor Diet and Supplementation**

Eating the right combination of foods, along with good supplementation, will greatly promote your success. Make your diet 50 percent carbohydrate, 35 percent protein, 15 percent fat, and take a good multivitamin and protein / carbohydrate supplement. Don't forget the water- at least 80 ounces a day! Hydration is critical.

8. **Stale Routines**

Your body adapts very quickly to the demands placed upon it. That's why you should have a variety of exercises and routines that you can do. To keep your body growing, you've got to keep it off-guard. Changing your exercises and routines is a sure way to do it.

PERSONAL PROGRAM

It is important to first establish specific and realistic goals. You should determine your long term goal and then set a series of short term goals that will help you attain your long term goal. The most common goals are:



Endurance & Definition



Increase Strength



Power & Muscle Mass

If your personal goals involve losing a considerable amount of body fat you will need to focus more on aerobic exercise and weight training for muscular endurance and definition. If your goals involve a large increase in muscle size you will need to focus on power and muscle mass weight training. Depending on your goals, you will have different nutritional requirements.

Once you have determined your personal goals, you will need to set up a schedule that helps you attain them. Set up a schedule that includes the number of workouts per week, the type of workout activity, the time of day for each workout, and the actual workout program. Don't forget to factor in the warm up and cool down periods. You may have to modify your current lifestyle to accommodate your new schedule. It's very important to include the following basic components to achieve successful results:



STRETCHING

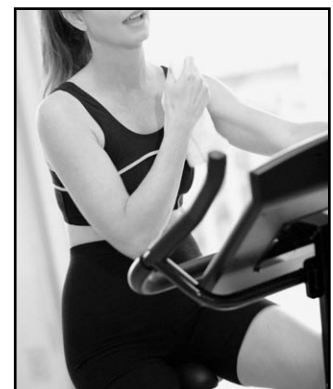

AEROBIC EXERCISE



WEIGHT TRAINING



NUTRITION

DETERMINE YOUR TRAINING METHOD

There are three basic types of weight training methods:

1. Training for muscular endurance and definition
2. Training for strength
3. Training for power and muscle mass

You should select a training method that reflects both your present fitness level and your long term goals. You should begin carefully and with proper professional guidance. You can always move from one training method to another as you progress.

If you are beginner, you should start slowly and carefully, gradually increasing the frequency and intensity of your training. Always play it safe – be realistic about your goals and your schedule. Realistic goals are safer and easier to follow.

Which is the right training method for you? First, take a look at your present physique and determine your objectives. Do you want a trim, toned, well-defined body? Are you involved in a sport where speed, strength and power are most important? Maybe you want bulging muscles and a terrific V-shape torso so you look great on the beach. Once you make a decision on what the final results should be, you can set up your personal program using the proper training method to achieve your goals.

Which training method is right for you?

FOR MUSCULAR ENDURANCE & DEFINITION

This training method incorporates achieving and maintaining a high cardiovascular (heart) rate and helps burn away excess fatty tissue. It also adds muscle definition and muscular endurance to your entire body. Exercises are most commonly performed for 15 to 20 repetitions and 3 to 4 sets using a light to moderate weight. The rest period between sets should be about 30 seconds. These short rest intervals will help maintain an elevated heart rate and prevent the muscles from cooling down.

FOR STRENGTH

This type of training is the most popular of the three and is designed specifically for increasing strength throughout the muscle and the muscle-tendon junction. This type of training is especially important for athletes. Normally, exercises are performed using moderate to heavy weight for 8 to 12 repetitions and 2 to 3 sets. The rest period between sets should be from 60 to 90 seconds. This allows a degree of muscle recovery before you hit them again.

FOR POWER AND MUSCLE MASS

This is the method most often used by bodybuilders and is recommended only for the intermediate and advanced lifter. The weights used are heavy – this shocks the muscles and stimulates a more rapid increase in muscle size. Usually exercises are performed for 2 to 6 repetitions and 3 to 4 sets using very heavy weight. The rest period between sets should be from 3 to 4 minutes. The prolonged rest periods allow ample time for recovery between sets.

DESIGNING YOUR PERSONAL ROUTINE

FIRST:

You need to decide which of the above training methods is best suited to accomplish your personal goals.

SECOND:

Study the exercise poster that came with your Body-Solid machine and select one or two exercises per body part (body parts are listed to the left of the exercise pictures). Be sure to include exercises for all body parts. If you leave out certain body parts your exercise routine and your body will not be balanced. If you are trying to increase muscle mass or increase strength to a muscle group it is alright to add extra exercises to the area you are particularly concerned about.

THIRD:

Coordinate your body part exercise program and your personal schedule. If you select one exercise per body part you can normally do your entire routine in the same workout. If you choose to do more than 12 exercises you may decide to divide your workout routine into upper and lower body exercises. You can split your schedule to work upper body one day and lower body the next day. Remember to rest each particular muscle group 48 hours before working it again.

FOURTH:

Order the exercises in your routine so you are working the large muscle groups first and the small muscle groups last.

FIFTH:

Keep a record! Write down the exercises, number of sets, number of reps and the amount of resistance (weight).

Beginner's Sample Workout Routine When Training For Definition

Exercise	Reps	Sets
Chest Press	15 to 20	3 or 4
Lat Pulldown	15 to 20	3 or 4
Shoulder Press	15 to 20	3 or 4
Tricep Pressdown	15 to 20	3 or 4
Bicep Curl	15 to 20	3 or 4
Leg Press/Squat	15 to 20	3 or 4
Leg Extension	15 to 20	3 or 4
Leg Curl	15 to 20	3 or 4
Calf Raise	15 to 20	3 or 4
Ab Crunch	20 to 30	3 or 4

Rest period between sets should be about 30 seconds.

EXERCISE TIPS

Listed below are Body-Solid's picks of the best exercises you can do for each body part. These exercises can be done using free weights, machines and multi-station gyms. Learn to do each exercise in proper form. You can make substitutions in your training and try variations of each using different Body-Solid grips, cable attachments and accessories to slightly change the emphasis of a particular exercise. Note: Many movements, especially multijoint exercises, work more than one muscle group. For example, your front deltoids and triceps are stimulated during bench / chest pressing movements.

CHEST

This powerful muscle group is the cornerstone of a well-developed upper body. To most thoroughly work your pecs, include both pressing and fly movements and vary the angle of the bench from decline to flat to incline.

BENCH / CHEST PRESS
INCLINE PRESS
DECLINE PRESS
PEC FLY
INCLINE FLY
DECLINE FLY
CABLE CROSSOVER
DIPS

SHOULDERS

The shoulder joint, which has the greatest range of motion of all joints in the body, is best worked by training all three deltoid heads. Include a pressing movement followed by a raise for each of the three heads.

SHOULDER PRESS
BEHIND THE NECK PRESS
FRONT DELTOID RAISE
LATERAL (SIDE) DELTOID RAISE
BENT-OVER LATERAL DELTOID RAISE
REVERSE PEC-FLY

UPPER BACK

A powerful upper back is marked by both middle-back thickness and width (the sought-after V-taper). This is best achieved by combining various rows with pull-downs and pull-ups. Remember to vary your grip to slightly change the stimulus.

PULL UP
UPRIGHT ROW
LAT PULLDOWN
SEATED ROW
BENT OVER ROW
HIGH ROW
REVERSE GRIP PULLDOWN

TRAPS

A signature muscle of a strong upper back, well-developed traps help prevent neck injury. Shrug movements should be done with heavy weights in a straight up-and-down motion.

STRAIGHT BAR SHRUG
DUMBBELL SHRUG
BEHIND THE BACK SHRUG
UPRIGHT ROW

LOWER BACK

Important not only for spinal protection but also because it's the seat of power for many exercises. If you spend a great deal of time crunching for abs, you need to balance your training for complete development and muscular balance.

PULL UP
UPRIGHT ROW
LAT PULLDOWN
SEATED ROW
BENT OVER ROW
HIGH ROW
REVERSE GRIP PULLDOWN

TRICEPS

This three-headed muscle on the back of your arm is involved in extension of the elbow. Like the biceps, the triceps cross the elbow and shoulder joints. Because of this, you can and should work the triceps through a variety of angles to ensure complete development.

LYING TRICEPS EXTENSION
CABLE TRICEPS EXTENSION
CABLE TRICEPS PRESSDOWN
CLOSE-GRIP BENCH PRESS
REVERSE-GRIP PRESSDOWN
TRICEPS PRESS
DIPS

BICEPS / FOREARMS

A two-headed muscle, the biceps' primary focus is to flex your elbow and supinate your wrist. The ability to build your biceps peak is largely genetic, but exercises that maximally stress the short head will help.

BICEPS
STANDING BICEP CURL
SEATED BICEP CURL
INCLINE CURL
PREACHER CURL
CONCENTRATION CURL
ONE-ARM CABLE CURL
FOREARMS
WRIST CURL
REVERSE WRIST CURL

ABDOMINALS

The rectus abdominus has upper and lower regions. Include both upper and lower ab movement to emphasize those areas, and do twisting movements to work the obliques for complete development.

UPPER AB REGION
CABLE AB CRUNCH
DECLINE BENCH CRUNCH
LOWER AB REGION
REVERSE CRUNCH
HANGING KNEE RAISE
HIP THRUST
OBLIQUES
CABLE SIDE BEND
OBLIQUE CRUNCH

THIGHS / GLUTES

The main muscles of the thighs are the quadriceps which are composed of four muscles. You have several others near the hip joint, including the body's largest muscle group, the gluteals. Multi-joint movements (in which action occurs at both the hip and knee joints) are your best choice to work these muscles.

BACK SQUAT
FRONT SQUAT
LEG PRESS
LUNGE
REVERSE LUNGE
STEP-UP
LEG EXTENSION (does not work glutes)

HAMSTRINGS

On the back of the thighs, the hamstrings balance the quads and allow for a wide range of movement. Good exercise choices include those that work the hamstrings and both the hip and knee joints.

DEADLIFT
STIFF-LEGGED DEADLIFT
GOOD MORNING
LYING LEG CURL
SEATED LEG CURL
ONE-LEGGED STANDING LEG CURL

CALVES

Calves consist of two major muscles, the gastrocnemius and soleus. The latter is best worked when the knee is flexed, as in the seated calf raise.

STANDING CALF RAISE
SEATED CALF RAISE
DONKEY CALF RAISE
LEG PRESS CALF RAISE
HACK SQUAT CALF RAISE

ANATOMY CHART

FRONT VIEW

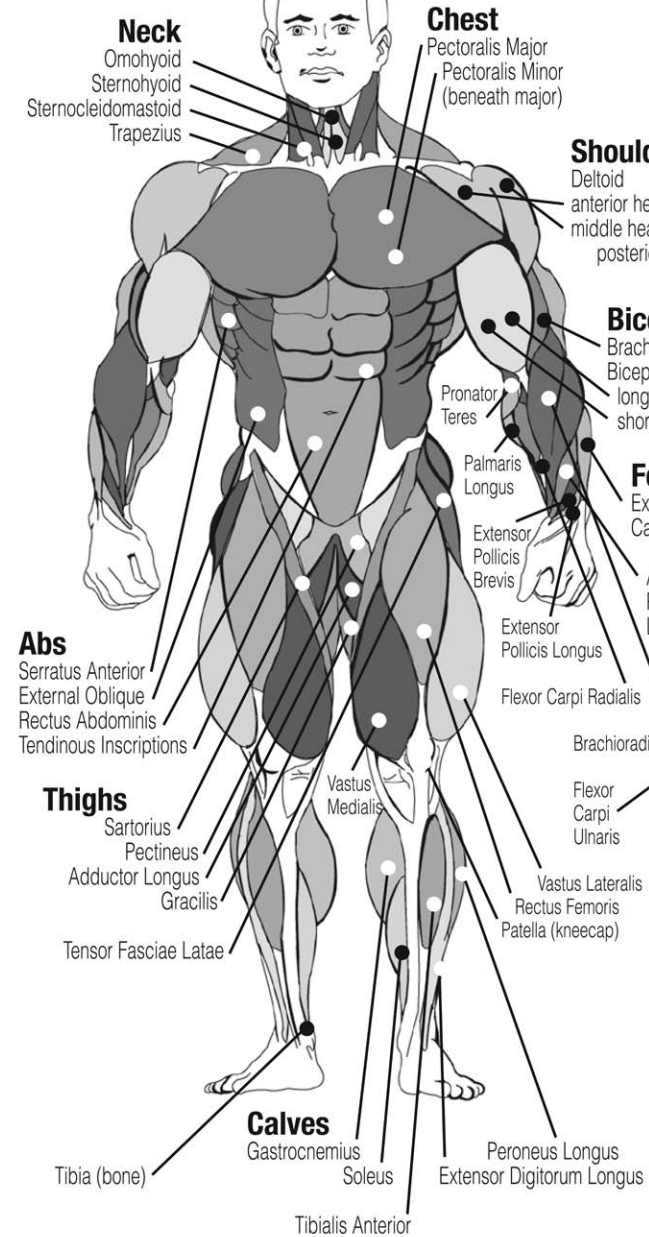

Note: These illustrations depicting exaggerated musculature are not in the textbook anatomical position. As such, they are inexact for medical purposes but are useful for a general understanding.

BACK VIEW

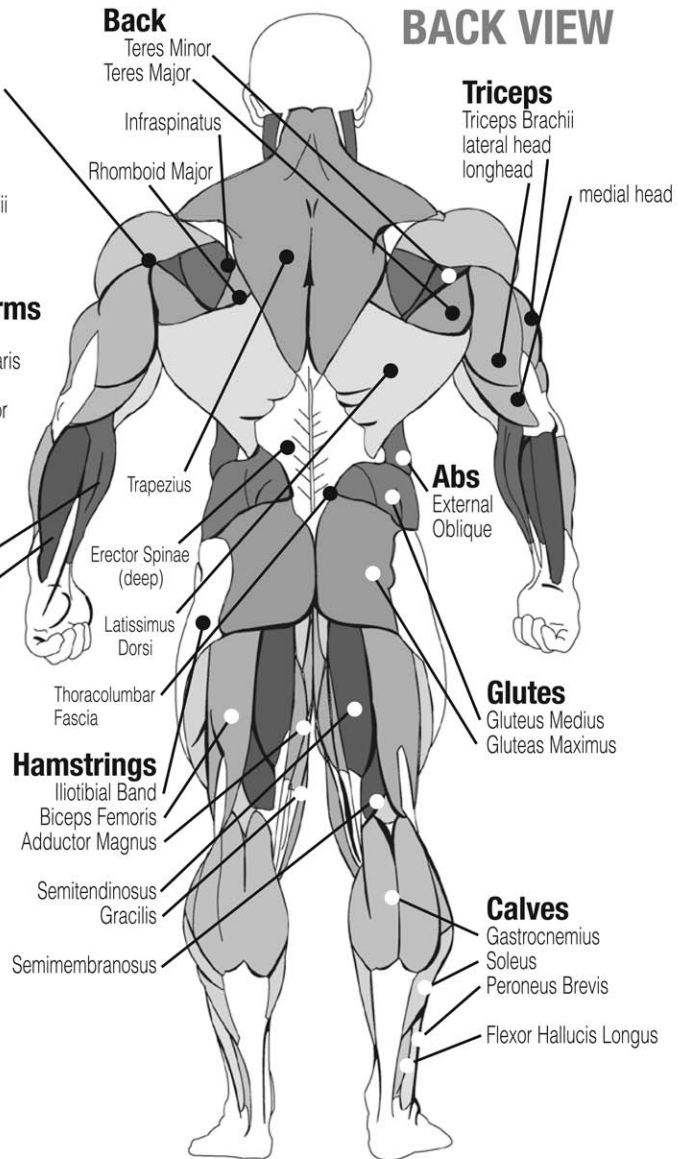

FITNESS GOALS

SHORT-TERM GOALS

Date Set _____ Date Accomplished _____

Goal _____

Reward** _____

Date Set _____ Date Accomplished _____

Goal _____

Reward** _____

Date Set _____ Date Accomplished _____

Goal _____

Reward** _____

LONG-TERM GOALS

Goal _____

Reward! _____

* Make several copies of this page to keep track of your goals and accomplishments.
** Don't forget to reward yourself for a job well-done!

EXERCISE LOG

S = Sets
R = Repetitions per set
W = Weight used

BEGINNER'S SAMPLE WORKOUT ROUTINE

Keep track of your changes and improvements. It's a great motivational tool!*

Date	S	R	W	S	R	W	S	R	W	S	R	W	S	R	W	S	R	W
Exercise																		
BENCH / CHEST PRESS																		
LAT PULLDOWN																		
SHOULDER PRESS																		
TRICEP PRESSDOWN																		
BICEP CURL																		
LEG PRESS / SQUAT																		
LEG EXTENSION																		
LEG CURL																		
CALF RAISE																		
AB CRUNCH																		
TOTALS																		

EXERCISE LOG

SAMPLE WORKOUT ROUTINE WHEN TRAINING FOR STRENGTH

Keep track of your changes and improvements. It's a great motivational tool!*

S = Sets
R = Repetitions per set
W = Weight used

Date	Date			Date			Date			Date			Date			Date		
	S	R	W	S	R	W	S	R	W	S	R	W	S	R	W	S	R	W
Exercise																		
LEG PRESS / SQUAT																		
LEG EXTENSION																		
LEG CURL																		
CALF RAISE																		
BENCH / CHEST PRESS																		
INCLINE PRESS																		
INCLINE PEC FLY																		
LAT PULLDOWN																		
SEATED ROW																		
MILITARY PRESS																		
UPRIGHT ROW																		
BICEP CURL																		
TRICEP PRESSDOWN																		
TRICEP EXTENSION																		
RESISTANCE AB CRUNCH																		
RESISTANCE OBLIQUE CRUNCH																		
TOTALS																		

STRETCHING

The following pages show illustrations with descriptions of static stretching for warm up and post-exercise cool down.

Remember... stretch your large muscle groups first and do all stretches in a smooth, slow, controlled manner.

Flexibility is an important component of physical fitness and needs to be addressed in a resistance training program. The two main purposes for stretching are injury prevention and a faster rate of recovery from exercise. Stretching should be performed in both the warm up and cool down phases of a training session. A good general guideline is that each workout session should be preceded by 5 to 15 minutes of general warm up, followed by 8 to 12 minutes of stretching, and concluded with 4 to 5 minutes of post-exercise stretching.

A regular stretching program will loosen muscle tissue, allowing an increased range of motion. This helps prevent microtears at the muscle-tendon junction. Almost 90% of all injuries from muscle strain occur at the muscle-tendon junction. Repeated injury at this junction can lead to a build-up of scar tissue, which impedes range of motion and adds stress to the joints.

Begin by stretching the major muscle groups first. Move in and out of your stretches with smooth, slow, controlled motion. Hold the stretch for at least 10 seconds when you feel you have reached your muscle's maximum distance. Do not use fast, hurried or reckless motions when stretching. Fast and bouncy motions will increase the risk of injury.

The most common and most popular type of stretching is the static stretching technique. This form of stretching involves voluntary, complete relaxation of the muscles while they are elongated. A static stretch is a constant, steady stretch in which the end position is held for 10 to 30 seconds. This technique is popular because it is easy to learn, effective, and accompanied by minimal soreness with the least risk of injury.

Ballistic stretching involves a bouncing or bobbing movement during the stretch. The final position in the movement is not held. Ballistic stretching is unpopular because of the increased amount of delayed muscle soreness and the possibility of injury during the stretching exercise. Ballistic stretching is not recommended.

A dynamic stretch involves flexibility during sport specific movements. Dynamic stretching is similar to ballistic stretching in that it utilizes movement, but dynamic stretching includes movements that may be specific to a sport or movement pattern. Dynamic stretching is most common among track and field athletes, but is also used in other sports, such as basketball and volleyball. An example of dynamic stretching would be a track sprinter performing high knees with an emphasis on knee height and arm action, not on horizontal speed.

STRETCHING

UPPER BACK

Cross Arm in Front of Chest

MUSCLE(S) AFFECTED: *latissimus dorsi and teres major*

1. Stand or sit with the right arm slightly flexed (15° to 30°) and adducted across the chest.
2. Grasp the upper arm just above the elbow, placing the left hand on the posterior side of the upper arm.
3. Pull the right arm across the chest (toward the left) with the left hand.
4. Hold for 10 seconds.
5. Repeat with the left arm.



Stretching the upper back

UPPER BACK

Arms Straight Up Above Head (Pillar)

MUSCLE(S) AFFECTED: *latissimus dorsi and wrist flexors*

1. Stand with arms in front of torso, fingers interlocked with palms facing each other.
2. Slowly straighten the arms above the head with palms up.
3. Continue to reach upward with hands and arms.
4. While continuing to reach upward, slowly reach slightly backward.
5. Hold for 10 seconds.



Stretching the shoulders, chest and upper back

LOWER BACK

Spinal Twist (Pretzel)

MUSCLE(S) AFFECTED: *internal oblique, external oblique and spinal erectors*

1. Sitting with legs straight and upper body nearly vertical, place right foot on left side of left knee.
2. Place back of left elbow on right side of right knee, which is now bent.
3. Place right palm on floor 12 to 16 inches behind hips.
4. Push right knee to the left with left elbow while turning shoulders and head to the right as far as possible. Try to look behind the back.
5. Hold for 10 seconds.
6. Repeat with left leg.



Stretching the lower back and sides

LOWER BACK

Semi-Leg Straddle

MUSCLE(S) AFFECTED: *spinal erectors*

1. Sitting, knees flexed 30 to 50 degrees, let the legs totally relax.
2. Point the knees outward; the lateral side of the knees may or may not touch the floor.
3. Lean forward from waist and reach forward with extended arms. Hold position for 10 to 15 seconds.
4. Bending and relaxing legs decreases hamstring involvement and increases lower back stretch.



Stretching the lower back from seated position

STRETCHING

SIDES

Side Bend with Straight Arms

MUSCLE(S) AFFECTED: *external oblique, latissimus dorsi and serratus anterior*

1. Stand with feet 14 to 16 inches apart.
2. Interlace the fingers with palms facing each other.
3. Reach upward with straight arms.
4. Keeping arms straight, lean from waist to left side. Do not bend knees.
5. After moving as far as possible, hold for 10 seconds.
6. Repeat to the left side.



Stretching the sides, upper back and shoulders

SHOULDER

Seated Lean-Back

MUSCLE(S) AFFECTED: *deltoids and pectoralis major*

1. Sitting with legs straight and arms extended, place palms on floor about 12 inches behind hips.
2. Point fingers away (backward) from body.
3. Slide hands backward and lean backward.
4. Hold for 10 seconds.



Stretching shoulders joints

CHEST

Straight Arms Behind Back

MUSCLE(S) AFFECTED: *deltoids and pectoralis major*

1. Standing, place both arms behind back.
2. Interlock fingers with palms facing each other.
3. Straighten arms fully.
4. Slowly raise the straight arms.
5. Hold for 10 to 15 seconds.
6. Keep head upright and neck relaxed.

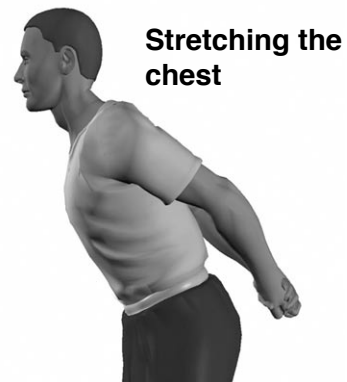

Stretching the chest

Remember... do all stretches in a smooth, slow, controlled manner.

STRETCHING

POSTERIOR OF THIGH

Sitting Toe Touch

MUSCLE(S) AFFECTED: *hamstrings, spinal erectors and gastrocnemius*

1. Sit with the upper body nearly vertical and legs straight.
2. Lean forward from waist and grasp toes with each hand, slightly pull toes towards the upper body, and pull chest towards leg. (If you are very stiff, try to grasp the ankles.) Hold for 10 seconds.
3. Release toes and relax foot.
4. Grasp ankles and continue to pull chest towards legs. Hold for 10 seconds.
5. Still grasping the ankles, point away from body and continue to pull chest towards legs. Hold for 10 seconds.

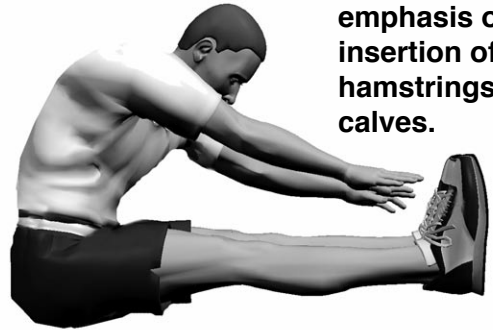

Stretching the hamstrings with emphasis on insertion of the hamstrings and calves.



Stretching the hamstrings with emphasis on the middle portion.



Stretching the hamstrings with emphasis on the upper portion.

GROIN

Butterfly

MUSCLE(S) AFFECTED: *adductors and sartorius*

1. Sitting with the upper body nearly vertical and legs straight, flex both knees as the soles of the feet come together.
2. Pull feet toward body.
3. Place hands on feet and elbows on legs.
4. Pull torso slightly forward as elbows push legs down.
5. Hold for 10 to 15 seconds.



Stretching the groin.

STRETCHING

GROIN

Straddle (Spread Eagle)

MUSCLE(S) AFFECTED: *gastrocnemius, hamstrings, spinal erectors, adductors and sartorius*

1. Sit with the upper body nearly vertical and legs straight, and spread legs as far as possible.
2. With right hand, grasp toes of right foot and pull on toes slightly, while pulling chest toward right leg. Hold for 10 seconds.
3. Release toes and relax foot.
4. Grasp ankle and continue to pull chest toward right leg. Hold for 10 seconds.
5. Point toes away from body and continue to pull chest toward right leg. Hold for 10 seconds.
6. Repeat process with the left leg.
7. Repeat process by grasping right toes with right hand and left toes with left hand. Move the torso forward and toward the ground.

Stretching the hamstring and groin with emphasis on insertion of the hamstrings and calves.

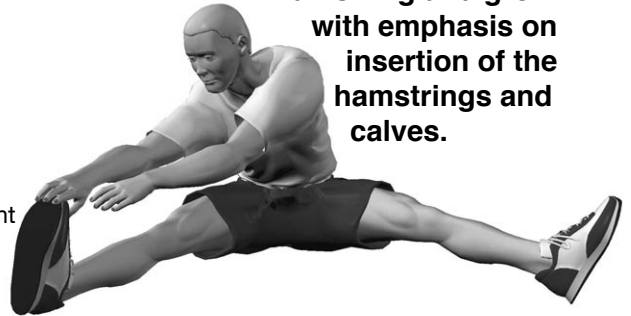

Stretching the hamstring and groin with emphasis on the upper portion.



Stretching the groin, lower back and hamstring.



STRETCHING

POSTERIOR OF LOWER LEG

Step Stretch

MUSCLE(S) AFFECTED: *gastrocnemius and soleus; also, achilles tendon*

1. Have ready a step or board 3 to 4 inches high.
2. Place balls of both feet on the step or board, 1 inch from its edge.
3. With straight legs, lower heels as far as possible.
4. Hold for 10 to 15 seconds.
5. To stretch achilles tendon, raise heels slightly. Slightly flex the knees and then lower the heels. This stretch will be felt in the achilles tendon.
6. Hold for 10 to 15 seconds.
7. For a more intense and individualized stretch, perform this stretch with one leg at a time.



Preparing to stretch the achilles tendon by slightly bending the knee.



Stretching the calves standing on a step.



Stretching the achilles tendon by lowering the heel.

HARDWARE

(Actual Size Shown)

Part# 11 M10x65 Carriage Bolt

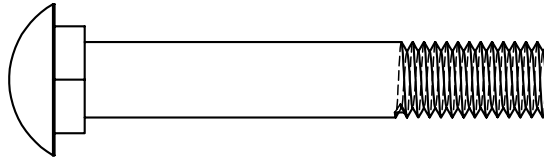

Part# 12 M10x65 Hex Head Bolt

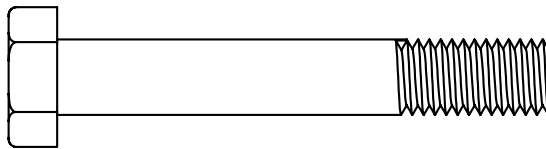

Part# 13 M8x65 Hex Head Bolt

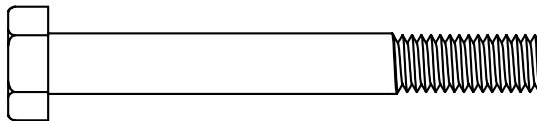

Part# 14 M10x20 Hex Head Bolt

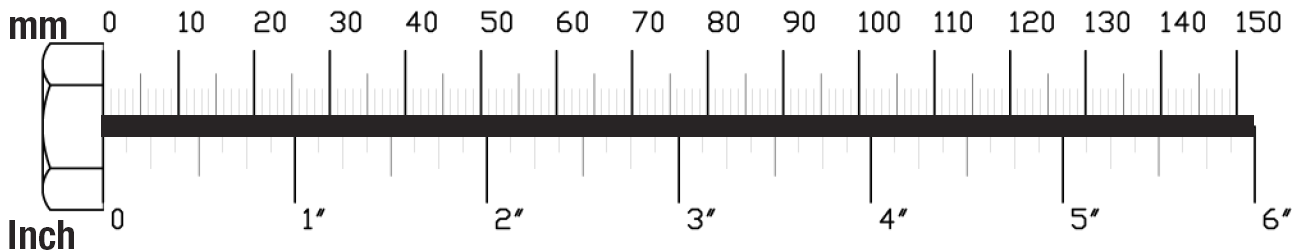
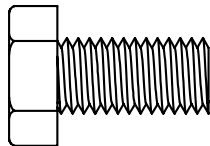

HARDWARE

(Actual Size Shown)

Part# 30 M10 Nylon Lock Nut

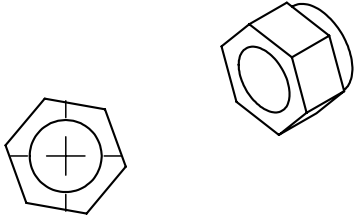

Part# 21 $\phi 8$ Washer

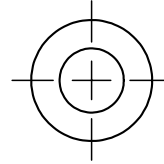

Part# 23 $\phi 10$ Washer

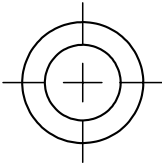

Part# 20 $\phi 10$ Large Washer

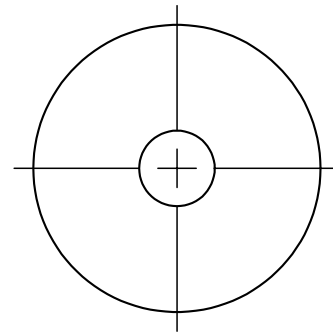

Part# 22 $\phi 8$ Spring Washer

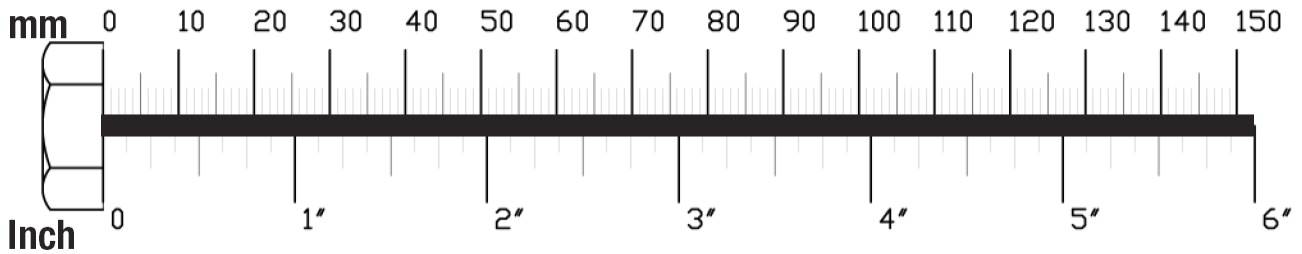
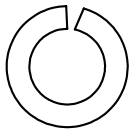

HARDWARE LIST

PART#	QTY	KEY#	DESCRIPTION
A	2		Foot Tube Assembly
B	1		Middle Tube Assembly 1
C	2		Elbow Tube Assembly
D	1		Middle Tube Assembly 2
E	1		Back Tube Assembly
F	1		Lat Bar Assembly
H	2		Handle Tube
K	2		Elbow Pad
M	1		Back Pad

Part numbers, key numbers, and description are required when ordering parts.

HARDWARE LIST

PART#	QTY	KEY#	DESCRIPTION
1	4		M50x50 Foot Cap
2	6		Plastic Sleeve
3	2		M50 End Cap
11	8		M10x65 Carriage Bolt
12	7		M10x65 Hex Head Bolt
13	6		M8x65 Hex Head Bolt
14	2		M10x20 Hex Head Bolt
20	22		φ10 Large Washer
21	6		φ8 Washer
22	6		φ8 Spring Washer
23	2		φ10 Washer
30	15		M10 Nylon Lock Nut

Part numbers, key numbers, and description are required when ordering parts.

EXPLODED VIEW DIAGRAM

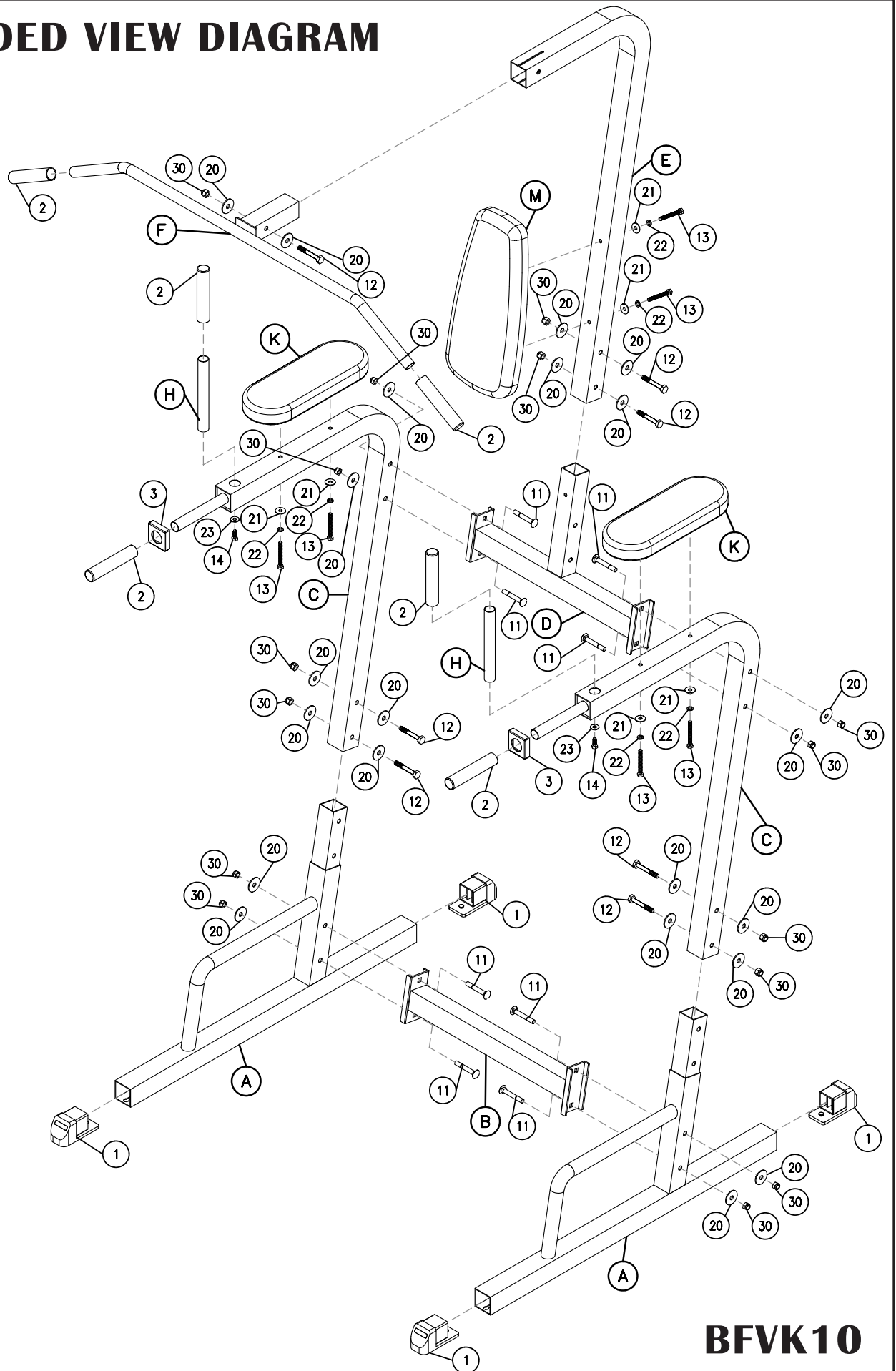

BFVK10



3-1 Warranty Registration Card

This Warranty applies only in the United States to products manufactured or distributed by Best Fitness under the Best Fitness brand name hereinafter referred to as "product". The warranty period to the original purchaser is 3 years on the frame and 1 year on ALL other parts.

Best Fitness warrants that the Product you have purchased for non-commercial, personal, family, or household use from Best Fitness or from an authorized Best Fitness reseller is free from defects in materials or workmanship under normal use during the warranty period. Your sales receipt, showing the date of purchase of the Product, is your proof of the date of purchase. This warranty extends only to you, the original purchaser. It is not transferable to anyone who subsequently purchases the Product from you. It excludes paint and finish. This Warranty becomes valid only if the Product is assembled / installed according to the instructions / directions included with the Product.

During the warranty period Best Fitness will, at no additional charge, repair or replace (at Best Fitness's option) the Product if it becomes defective, malfunctions, or otherwise fails to conform with this Warranty under normal non-commercial, personal, family, or household use. Use of this product in a commercial, institutional, or other public access environment will cause this warranty to be voided. In repairing the product Best Fitness may replace defective parts or, at the option of Best Fitness, serviceable used parts that are equivalent to new parts in performance. All exchanged parts and Products replaced under this warranty will become the property of Best Fitness. Best Fitness reserves the right to change manufacturers of any part to cover any existing warranty.

To obtain warranty service, you must return the Product to Best Fitness in its original container (or equivalent). You must pre-pay any shipping charges, export taxes, customs duties and taxes, or any other charges associated with transportation of the Product. In addition, you are responsible for insuring any Product shipped or returned. You assume the risk of loss during shipment. You must present Best Fitness with proof-of-purchase documents (including the date of purchase). Any evidence of alteration, erasing or forgery of proof-of-purchase documents will be cause to void this Warranty.

This Warranty does not extend to any product not purchased from Best Fitness or from an authorized Best Fitness reseller. This Warranty does not extend to any product that has been damaged or rendered defective; (a) as a result of accident, misuse, or abuse; (b) by the use of parts not manufactured or sold by Best Fitness; (c) by modification of the Product; (d) as a result of service by anyone other than Best Fitness, or an authorized Best Fitness warranty service provider. Should any product submitted for Warranty service be found to be ineligible, an estimate of repair cost will be furnished and the repair will be made if requested by you upon Best Fitness's receipt of payment or acceptable arrangement of payment.

EXCEPT AS EXPRESSLY SET FORTH IN THIS WARRANTY BEST FITNESS MAKES NO OTHER WARRANTIES, EXPRESSED OR IMPLIED INCLUDING ANY IMPLIED WARRANTIES OF MERCHANTABILITY AND FITNESS FOR A PARTICULAR PURPOSE. BEST FITNESS EXPRESSLY DISCLAIMS ALL WARRANTIES NOT STATED IN THIS WARRANTY. ANY IMPLIED WARRANTIES THAT MAY BE IMPOSED BY LAW ARE LIMITED TO THE TERMS OF THIS WARRANTY. NEITHER BEST FITNESS NOR ANY OF ITS AFFILIATES SHALL BE RESPONSIBLE FOR INCIDENTAL OR CONSEQUENTIAL DAMAGES. SOME STATES DO NOT ALLOW LIMITATIONS ON HOW LONG AN IMPLIED WARRANTY LASTS OR THE EXCLUSION OR LIMITATION OF INCIDENTAL OR CONSEQUENTIAL DAMAGES, SO THE ABOVE LIMITATIONS OR EXCLUSION MAY NOT APPLY TO YOU. This Warranty gives you specific legal rights and you may also have other rights that may vary from state to state. This is the only express warranty applicable to Best Fitness branded products. Best Fitness neither assumes nor authorizes anyone to assume for it any other express warranty.

—Warranty is not applicable outside the United States—

Before returning a product you must call Best Fitness at 1-866-348-6362 to obtain a Return Authorization Number.

No returns will be accepted without the Return Authorization Number. Original purchaser must pre-pay all freight charges on warranty claims.

Best Fitness will not accept Freight Collect shipments or return shipments on a freight collect basis.

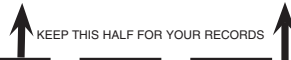

Best Fitness

One Year Warranty Registration Card

Congratulations! You have just purchased a quality BEST FITNESS product. You must fill out this Warranty Registration Card completely, and return it to Best Fitness within 10 days of purchase for this warranty to be valid.

First Name	Initial	Last Name
_____	_____	_____
Street	Apt. No.	
_____	_____	
City	State	Zip Code
_____	_____	_____
Country	Phone	
_____	_____	

ITEM NO. _____

ITEM NAME _____

DATE OF PURCHASE _____

- Where did you purchase this product from?

- Who will use this product?
____ % Male ____ % Female
- Age of product user?
 Under 24 45-54
 25-34 55-64
 35-44 Over 65
- Household Income?
 Under \$15,000 \$45,000 - \$60,000
 \$15,000 - \$30,000 \$60,000 - \$75,000
 \$30,000 - \$45,000 \$75,000 Plus

- How did you learn of this product?
 TV Friend
 Radio Print ad / Flyer
 In Store Display Catalog
 Salesperson Other _____
- Why did you choose our product?
 Quality Brand Name
 Features Price / Value
 Appearance / Style Warranty
 Design / Function Other _____

CAUTION • PLEASE NOTE • WARNING
THERE IS A RISK ASSUMED BY INDIVIDUALS WHO USE THIS TYPE OF EQUIPMENT TO MINIMIZE RISK. YOU MUST FOLLOW THESE RULES:

- Inspect equipment before each workout. Check that all nuts, bolts, screws and pop pins are in place and fully tightened. Also, before use, check cables for signs of wear. Replace all worn parts immediately. Never use machine if any parts are damaged or missing. Failure to follow these rules may result in serious injury.
- Keep clear of the cables and all moving parts when the machine is in use.
- Always make sure all Snap Links are closed when doing any cable / pulley exercises.
- Exercise with care. Perform your exercises at a smooth moderate pace; never perform jerky or uncoordinated movements that may cause injury.
- It is recommended that you should workout with a training partner.
- Do not allow children or minors to play on or around this equipment.
- If unsure of proper use of equipment, call your local Best Fitness distributor or the Best Fitness customer service department at 1-866-348-6362.
- WARNING:** Consult your physician before starting your exercise program. For your own safety, do not begin any exercise program without proper instruction.

Please sign: _____

 Signature



WARRANTY Registration Card

(SEE DETAILS ON BACK)

PURCHASE

CAUTION • PLEASE NOTE • WARNING
THERE IS A RISK ASSUMED BY INDIVIDUALS WHO USE THIS TYPE OF EQUIPMENT. TO MINIMIZE RISK, YOU MUST FOLLOW THESE RULES:

1. Inspect equipment before each workout. Check that all nuts, bolts, screws and pop pins are in place and fully tightened. Also, before use, check cables for signs of wear. Replace all worn parts immediately. Never use machine if any parts are damaged or missing. Failure to follow these rules may result in serious injury.
2. Keep clear of the cables and all moving parts when the machine is in use.
3. Always make sure all Snap Links are closed when doing any cable / pulley exercises.
4. Exercise with care. Perform your exercises at a smooth moderate pace; never perform jerky or uncoordinated movements that may cause injury.
5. It is recommended that you should workout with a training partner.
6. Do not allow children or minors to play on or around this equipment.
7. If unsure of proper use of equipment, call your local Best Fitness distributor or the Best Fitness customer service department at 1-866-348-6362.
8. **WARNING:** Consult your physician before starting your exercise program. For your own safety, do not begin any exercise program without proper instruction.

PLACE
STAMP
HERE

FROM:

Name: _____

Address: _____ Apt#: _____

City: _____ State: _____ Zip Code: _____



**1900 S. Des Plaines Ave.
Forest Park, IL 60130**

IMPORTANT!

Best Fitness Warranty Registration Card